

Administrator's Guide

Life Scope *TR*

Bedside Monitor

BSM-6301/BSM-6501/BSM-6701

BSM-6000 series
BSM-6301A
BSM-6301K
BSM-6501A
BSM-6501K
BSM-6701A
BSM-6701K

In order to use this product safely and fully understand all its functions, read this manual before using the product.

Keep this manual near the instrument or in the reach of the operator and refer to it whenever the operation is unclear.

This product stores personal patient information. Manage the information appropriately.

Patient names on the screen shots and recording examples in this manual are fictional and any resemblance to any person living or dead is purely coincidental.

The contents of this manual are subject to change without notice.

If you have any comments or suggestions on this manual, please contact us at: www.nihonkohden.com

Copyright Notice

The entire contents of this manual are copyrighted by Nihon Kohden. All rights are reserved. No part of this document may be reproduced, stored, or transmitted in any form or by any means (electronic, mechanical, photocopied, recorded, or otherwise) without the prior written permission of Nihon Kohden.

Trademark



The mark printed on the SD card that is used in this instrument is a trademark. The company name and model name are trademarks and registered trademarks of each company.

CE **Rx**
0086 **Only**

Contents

1

2

3

4

GENERAL HANDLING PRECAUTIONS	i
WARRANTY POLICY	ii
EMC RELATED CAUTION	ii
Conventions Used in this Manual and Instrument	v
Warnings, Cautions and Notes	v
Text Conventions	v
Related Documentation	v
Safety Standards	vi
Periodic Inspection.....	vi

Section 1 **Installation/Connection 1.1**

Installation Conditions.....	1.2
Optional Cart for the Bedside Monitor	1.3
Optional Wall Mount Kit and Counter Top Mount for the Bedside Monitor.....	1.3
Installation Flowchart.....	1.4
Installing the Optional Units to the Monitor and Connecting External Instruments.....	1.5
Connection Overview.....	1.8
Attaching the AA-672P or AA-674P Smart Expansion Unit to the AY series Input Unit	1.9
Mounting the AY series Input Unit or BSM-1700 series Bedside Monitor onto the Monitor.....	1.9
Using an Optional Handle	1.10
Attaching the ZS-900P Transmitter.....	1.10
Installing the WS-671P Recorder Module.....	1.11
Installing the QI-631P, QI-632P, QI-634P, QI-671P or QI-672P Interface	1.11
Connecting the Mouse.....	1.12
Connecting the Bar Code Reader	1.12
Mounting the QI-670P Interface on the Monitor.....	1.12
Connecting the JA-690PA or JA-694PA Data Acquisition Unit	1.13
Connecting External Instruments	1.14
Connecting a GF-110PA or GF-210R Multigas Unit, GF-120PA or GF-220R Multigas/Flow Unit or AE-918P Neuro Unit.....	1.14
Connecting an External Instrument Using a QF series Interface or IF series Communication Cable.....	1.15
Connecting a Sub Display	1.15
Connecting the Power Cord and Grounding Lead	1.17
General.....	1.17
Connecting the Power Cord.....	1.17
Grounding the Monitor.....	1.18
Cutting Off the Power Supply to the Monitor.....	1.18
Connecting the Monitor to the Network	1.19
Connecting the HIT-100 Hyper Isolation Transformer	1.20
Connecting the QI-320PA or QI-420PA Wireless LAN Station.....	1.20
Turning the Power On/Off	1.21
Check Before Turning On the Power.....	1.21
Turning the Power On	1.21

Check After Turning On the Power and During Monitoring 1.23

Stored Data Status at Power On..... 1.23

Monitor Status on Power Interruption 1.23

Turning the Power Off 1.24

Check After and Before Turning the Power Off 1.24

Setting the Bar Code Reader..... 1.25

 Scanning the Bar Code Reader Settings..... 1.25

 Initializing the Bar Code Reader 1.26

 Checking the Bar Code Reader Operation 1.26

Calibrating the Touch Screen 1.27

Using ECG/BP Output as the Synchronous Signal 1.28

Section 2 *Changing SYSTEM CONFIGURATION Screen Settings 2.1*

Overview 2.2

 Setting Items on the SYSTEM CONFIGURATION Screen..... 2.2

 Displaying the SYSTEM CONFIGURATION Screen 2.3

 Closing the SYSTEM CONFIGURATION Screen..... 2.5

SITE Window 2.6

NETWORK Window 2.8

 IP ADDRESS/PROTOCOL Page..... 2.8

 LS-NET Page..... 2.9

 HL7 Page..... 2.10

UNITS Window 2.12

DATA MANAGEMENT Window 2.13

PC Window 2.17

CHANGE PASSWORD Window 2.18

OPTIONS Window 2.19

OTHER Window 2.20

Initializing the Monitor 2.22

Section 3 *Changing SYSTEM SETUP Window Settings 3.1*

Overview 3.3

 Setting Items on the SYSTEM SETUP Window 3.3

 Displaying the SYSTEM SETUP Window 3.9

 Closing the SYSTEM SETUP Window 3.10

 The INFO Page of the INFO Window 3.11

 The CONFIGURATION Page of the INFO Window 3.11

 The MAINTENANCE Page of the INFO Window..... 3.12

 BATTERY Tab..... 3.12

 LOAD/SAVE SETTINGS Tab..... 3.12

SYSTEM Window 3.15

 DISPLAY Page..... 3.15

 LAYOUT Page..... 3.17

 VOLUME Page 3.20

 INTERBED Page 3.21

BED ID Window 3.22

PARAMETERS Window 3.23

 ECG Page..... 3.23

 NIBP Page..... 3.25

NIBP MODE Page	3.27	1
STAT Tab.....	3.27	
SIM Tab	3.28	2
INTERVAL Tab.....	3.29	
VENOUS PUNCTURE Tab.....	3.29	3
INITIAL CUFF PRESS Tab.....	3.30	
CO ₂ Page.....	3.30	4
GAS Page.....	3.31	
MAINTENANCE Tab.....	3.31	
SETTINGS Tab.....	3.31	
INFO Tab	3.33	
FLOW/Paw Page	3.33	
CAL Tab.....	3.33	
SETTINGS Tab.....	3.34	
MAINTENANCE Tab.....	3.34	
INFO Tab	3.35	
EEG Page.....	3.35	
OTHER PARAM Page.....	3.36	
ALARM Window	3.38	
SILENCE/SUSPEND Page.....	3.38	
DISPLAY/SOUND Page.....	3.40	
ALARM PRIORITY Page.....	3.42	
ARRHYTH PRIORITY Page.....	3.48	
TECHNICAL PRIORITY Page.....	3.49	
SLEEP Page.....	3.50	
NETWORK Page.....	3.51	
ALARM CAP Page.....	3.52	
LATCHING Page.....	3.53	
COLOR Window	3.55	
RECORD Window.....	3.57	
RECORDER Page.....	3.57	
PRINTER Page.....	3.59	
Using Network Printer	3.60	
MASTER Window	3.62	
PATIENT TYPE Page.....	3.63	
Renaming an Alarm Master.....	3.63	
MAIN ALARMS, ECG ALARMS, PRESS ALARMS, TEMP ALARMS, GAS ALARMS, OTHER ALARMS Pages.....	3.64	
ARRHYTH Page	3.65	
RY-910P/MOUSE Window	3.67	
KEYS Window.....	3.68	

Section 4 Reference..... 4.1

Factory Default Settings.....	4.2
SYSTEM CONFIGURATION Screen.....	4.3
SYSTEM SETUP Window	4.5
General Requirements for Connecting Medical Electrical Systems.....	4.22
Connector Pin Assignment	4.23
MU-631R/MU-651R/MU-671R Main Unit	4.23
QI-631P Interface	4.23

QI-632P Interface	4.24
QI-634P Interface	4.24
QI-671P Interface	4.25
QI-672P Interface	4.26
AY-631P/AY-633P/AY-651P/AY-653P/AY-661P/AY-663P/AY-671P/AY-673P Input Unit and BSM-1700 series Bedside Monitor.....	4.26
Check Sheet for Unit Settings.....	4.27

GENERAL HANDLING PRECAUTIONS

This device is intended for use only by qualified medical personnel.

Use only Nihon Kohden approved products with this device. Use of non-approved products or in a non-approved manner may affect the performance specifications of the device. This includes, but is not limited to, batteries, recording paper, pens, extension cables, electrode leads, input boxes and AC power.

Please read these precautions thoroughly before attempting to operate the instrument.

- 1. To safely and effectively use the instrument, its operation must be fully understood.**
- 2. When installing or storing the instrument, take the following precautions.**
 - (1) Avoid moisture or contact with water, extreme atmospheric pressure, excessive humidity and temperatures, poorly ventilated areas, and dust, saline or sulphuric air.
 - (2) Place the instrument on an even, level floor. Avoid vibration and mechanical shock, even during transport.
 - (3) Avoid placing in an area where chemicals are stored or where there is danger of gas leakage.
 - (4) The power line source to be applied to the instrument must correspond in frequency and voltage to product specifications, and have sufficient current capacity.
 - (5) Choose a room where a proper grounding facility is available.
- 3. Before Operation**
 - (1) Check that the instrument is in perfect operating order.
 - (2) Check that the instrument is grounded properly.
 - (3) Check that all cords are connected properly.
 - (4) Pay extra attention when the instrument is combined with other instruments to avoid misdiagnosis or other problems.
 - (5) All circuitry used for direct patient connection must be doubly checked.
 - (6) Check that battery level is acceptable and battery condition is good when using battery-operated models.
- 4. During Operation**
 - (1) Both the instrument and the patient must receive continual, careful attention.
 - (2) Turn power off or remove electrodes and/or transducers when necessary to assure the patient's safety.
 - (3) Avoid direct contact between the instrument housing and the patient.
- 5. To Shutdown After Use**
 - (1) Turn power off with all controls returned to their original positions.
 - (2) Remove the cords gently; do not use force to remove them.
 - (3) Clean the instrument together with all accessories for their next use.
- 6. The instrument must receive expert, professional attention for maintenance and repairs. When the instrument is not functioning properly, it should be clearly marked to avoid operation while it is out of order.**
- 7. The instrument must not be altered or modified in any way.**
- 8. Maintenance and Inspection**
 - (1) The instrument and specified parts must undergo regular maintenance inspection at the interval which is specified after the GENERAL HANDLING PRECAUTIONS section.
 - (2) If stored for extended periods without being used, make sure prior to operation that the instrument is in perfect operating condition.

- (3) Technical information such as parts list, descriptions, calibration instructions or other information is available for qualified user technical personnel upon request from your Nihon Kohden representative.
9. **When the instrument is used with an electrosurgical instrument, pay careful attention to the application and/or location of electrodes and/or transducers to avoid possible burn to the patient.**
10. **When the instrument is used with a defibrillator, make sure that the instrument is protected against defibrillator discharge. If not, remove patient cables and/or transducers from the instrument to avoid possible damage.**

WARRANTY POLICY

Nihon Kohden Corporation (NKC) shall warrant its products against all defects in materials and workmanship for one year from the date of delivery. However, consumable materials such as recording paper, ink, stylus and battery are excluded from the warranty.

NKC or its authorized agents will repair or replace any products which prove to be defective during the warranty period, provided these products are used as prescribed by the operating instructions given in the operator's and service manuals.

No other party is authorized to make any warranty or assume liability for NKC's products. NKC will not recognize any other warranty, either implied or in writing. In addition, service, technical modification or any other product change performed by someone other than NKC or its authorized agents without prior consent of NKC may be cause for voiding this warranty.

Defective products or parts must be returned to NKC or its authorized agents, along with an explanation of the failure. Shipping costs must be pre-paid.

This warranty does not apply to products that have been modified, disassembled, reinstalled or repaired without Nihon Kohden approval or which have been subjected to neglect or accident, damage due to accident, fire, lightning, vandalism, water or other casualty, improper installation or application, or on which the original identification marks have been removed.

In the USA and Canada other warranty policies may apply.

CAUTION

United States law restricts this product to sale by or on the order of a physician.

EMC RELATED CAUTION

This equipment and/or system complies with IEC 60601-1-2 International Standard for electromagnetic compatibility for medical electrical equipment and/or system. However, an electromagnetic environment that exceeds the limits or levels stipulated in IEC 60601-1-2, can cause harmful interference to the equipment and/or system or cause the equipment and/or system to fail to perform its intended function or degrade its intended performance. Therefore, during the operation of the equipment and/or system, if there is any undesired deviation from its intended operational performance, you must avoid, identify and resolve the adverse electromagnetic effect before continuing to use the equipment and/or system.

The following describes some common interference sources and remedial actions:

1. Strong electromagnetic interference from a nearby emitter source such as an authorized radio station or cellular phone:
Install the equipment and/or system at another location. Keep the emitter source such as cellular phone away from the equipment and/or system, or turn off the cellular phone.
2. Radio-frequency interference from other equipment through the AC power supply of the equipment and/or system:
Identify the cause of this interference and if possible remove this interference source. If this is not possible, use a different power supply.
3. Effect of direct or indirect electrostatic discharge:
Make sure all users and patients in contact with the equipment and/or system are free from direct or indirect electrostatic energy before using it. A humid room can help lessen this problem.
4. Electromagnetic interference with any radio wave receiver such as radio or television:
If the equipment and/or system interferes with any radio wave receiver, locate the equipment and/or system as far as possible from the radio wave receiver.
5. Interference of lightning:
When lightning occurs near the location where the equipment and/or system is installed, it may induce an excessive voltage in the equipment and/or system. In such a case, disconnect the AC power cord from the equipment and/or system and operate the equipment and/or system by battery power, or use an uninterruptible power supply.
6. Use with other equipment:
When the equipment and/or system is adjacent to or stacked with other equipment, the equipment and/or system may affect the other equipment. Before use, check that the equipment and/or system operates normally with the other equipment.
7. Use of unspecified accessory, transducer and/or cable:
When an unspecified accessory, transducer and/or cable is connected to this equipment and/or system, it may cause increased electromagnetic emission or decreased electromagnetic immunity. The specified configuration of this equipment and/or system complies with the electromagnetic requirements with the specified configuration. Only use this equipment and/or system with the specified configuration.
8. Use of unspecified configuration:
When the equipment and/or system is used with the unspecified system configuration different than the configuration of EMC testing, it may cause increased electromagnetic emission or decreased electromagnetic immunity. Only use this equipment and/or system with the specified configuration.
9. Measurement with excessive sensitivity:
The equipment and/or system is designed to measure bioelectrical signals with a specified sensitivity. If the equipment and/or system is used with excessive sensitivity, artifact may appear by electromagnetic interference and this may cause mis-diagnosis. When unexpected artifact appears, inspect the surrounding electromagnetic conditions and remove this artifact source.

Caution - continued

10. Use with radiation therapy equipment:

When the equipment and/or system is used in a radiotherapy room, it may cause failure or malfunction due to electromagnetic radiation or corpuscular radiation. When you bring the equipment and/or system into a radiotherapy room, constantly observe the operation. Prepare countermeasures in case of failure or malfunction.

If the above suggested remedial actions do not solve the problem, consult your Nihon Kohden representative for additional suggestions.

BSM-6301 and BSM-6501 (JA-690PA or JA-694PA data acquisition unit, QE-910P BIS processor, AE-918P neuro unit, JP-911P IBP interface isolation cable, QI-320PA or QI-420PA wireless LAN station and QI-670P interface are not connected) comply with International Standard IEC 60601-1-2: 2001 and Amendment 1: 2004 which requires CISPR11, Group 1, Class B. Class B EQUIPMENT is equipment suitable for use in domestic establishments and in establishments directly connected to a low voltage power supply network which supplies buildings used for domestic purposes.

BSM-6301, BSM-6501 (JA-690PA or JA-694PA data acquisition unit, QE-910P BIS processor, AE-918P neuro unit, JP-911P IBP interface isolation cable, QI-320PA or QI-420PA wireless LAN station or QI-670P interface is connected) and BSM-6701 comply with International Standard IEC 60601-1-2: 2001 and Amendment 1: 2004 which requires CISPR11, Group 1, Class A. Class A EQUIPMENT is equipment suitable for use in industrial or light industrial establishments and commercial environment.

BSM-6301 and BSM-6501 (when ZS-900P is connected) are CLASS A equipment if the equipment complies with IEC 60601-1-2: 2001 36 201.1.5 in the countries which do not have national wireless rule.

WARNING

The bioelectric impedance measurement sensor of a minute ventilation rate-adaptive implantable pacemaker may be affected by cardiac monitoring and diagnostic equipment which is connected to the same patient. If this occurs, the pacemaker may pace at its maximum rate and give incorrect data to the monitor or diagnostic equipment. If this occurs, disconnect the monitor or diagnostic equipment from the patient or change the setting on the pacemaker by referring to the pacemaker's manual. For more details, contact your pacemaker representative or Nihon Kohden representative.

The CE mark is a protected conformity mark of the European Community. Products with the CE mark comply with the requirements of the Medical Device Directive 93/42/EEC.

NOTE about Waste Electrical and Electronic Equipment (WEEE) directive 2002/96/EC

For the member states of the European Union only:

The purpose of WEEE directive 2002/96/EC is, as a first priority, the prevention of waste electrical and electronic equipment (WEEE), and in addition, the reuse, recycling and other forms of recovery of such wastes so as to reduce the disposal of waste.

Contact your Nihon Kohden representative for disposal.

Conventions Used in this Manual and Instrument

Warnings, Cautions and Notes

Warnings, cautions and notes are used in this manual to alert or signal the reader to specific information.

WARNING

A warning alerts the user to possible injury or death associated with the use or misuse of the instrument.

CAUTION

A caution alerts the user to possible injury or problems with the instrument associated with its use or misuse such as instrument malfunction, instrument failure, damage to the instrument, or damage to other property.

NOTE

A note provides specific information, in the form of recommendations, prerequisites, alternative methods or supplemental information.

Text Conventions

- Names of hard keys on the bedside monitor are enclosed in square brackets: [Menu]
- Messages that are displayed on the screen are enclosed in quotation marks: "CHECK ELECTRODES"
- Names of items that are displayed on the screen are enclosed in angle brackets: <SENSITIVITY>

Related Documentation

The BSM-6000A/K series Bedside Monitor comes with the following manuals in addition to the Operator's Manual.

Administrator's Guide

Describes how to install the bedside monitor. It also explains about the password protected settings on the SYSTEM SETUP window and SYSTEM CONFIGURATION screen which only an administrator can change.

User's Guide, Part I

Gives supplemental information on the operation of the bedside monitor.

User's Guide, Part II

Describes the features and settings of the monitoring parameters.

Service Manual

Describes information on servicing the bedside monitor. Only qualified service personnel can service the bedside monitor.

Safety Standards

The safety standard of this bedside monitor is classified as follows:

Type of protection against electrical shock: CLASS I EQUIPMENT (AC Powered)
Internally Powered EQUIPMENT (BATTERY Powered)

Degree of protection against electrical shock

Defibrillator-proof type CF applied part:

AY-631P, AY-633P, AY-651P, AY-653P, AY-661P, AY-663P, AY-671P and AY-673P:

ECG, Respiration (impedance and thermistor method), IBP, Temperature, SpO₂, SpO₂-2, CO₂, O₂, NIBP, BIS, CCO (APCO)

AY-660P: ECG, Respiration (impedance method), IBP, Temperature, SpO₂, CO₂, NIBP

AA-672P, AA-674P, JA-694P: Respiration (thermistor method), IBP, Temperature, SpO₂-2, CO₂, O₂, BIS, CCO (APCO)

BSM-1700 series: ECG, Respiration (impedance method), IBP, Temperature, SpO₂, SpO₂-2, CO₂, NIBP, BIS

CF applied part:

AY-631P, AY-633P, AY-651P, AY-653P, AY-661P, AY-663P, AY-671P, AY-673P, AA-672P, AA-674P, JA-694P and BSM-1700 series: CO

Degree of protection against harmful ingress of water:

IPX0 (non-protected)

Degree of safety of application in the presence of FLAMMABLE ANAESTHETIC MIXTURE WITH AIR, OR WITH OXYGEN OR NITROUS OXIDE:

Equipment not suitable for use in the presence of FLAMMABLE ANAESTHETIC MIXTURE WITH AIR, OR WITH OXYGEN OR NITROUS OXIDE

Mode of operation: CONTINUOUS OPERATION

Periodic Inspection

If the periodic inspection is not performed, degradation or loss of function may go unnoticed and lead to misdiagnosis.

Service personnel should perform the periodic inspection at least once every year. Make sure that the bedside monitor operates properly and replace the consumables.

If you found abnormalities as a result of inspection and the bedside monitor is suspected to be faulty, attach an "Unusable" or "Repair request" label to the bedside monitor and contact your Nihon Kohden representative. For inspection, refer to the Service Manual.

Section 1 Installation/Connection

Installation Conditions	1.2
Optional Cart for the Bedside Monitor	1.3
Optional Wall Mount Kit and Counter Top Mount for the Bedside Monitor.....	1.3
Installation Flowchart.....	1.4
Installing the Optional Units to the Monitor and Connecting External Instruments	1.5
Connection Overview	1.8
Attaching the AA-672P or AA-674P Smart Expansion Unit to the AY series Input Unit.....	1.9
Mounting the AY series Input Unit or BSM-1700 series Bedside Monitor onto the Monitor	1.9
Using an Optional Handle	1.10
Attaching the ZS-900P Transmitter.....	1.10
Installing the WS-671P Recorder Module	1.11
Installing the QI-631P, QI-632P, QI-634P, QI-671P or QI-672P Interface	1.11
Connecting the Mouse	1.12
Connecting the Bar Code Reader	1.12
Mounting the QI-670P Interface on the Monitor	1.12
Connecting the JA-690PA or JA-694PA Data Acquisition Unit	1.13
Connecting External Instruments	1.14
Connecting a GF-110PA or GF-210R Multigas Unit, GF-120PA or GF-220R Multigas/Flow Unit or AE-918P Neuro Unit	1.14
Connecting an External Instrument Using a QF series Interface or IF series Communication Cable.....	1.15
Connecting a Sub Display	1.15
Connecting the Power Cord and Grounding Lead.....	1.17
General.....	1.17
Connecting the Power Cord	1.17
Grounding the Monitor.....	1.18
Cutting Off the Power Supply to the Monitor	1.18
Connecting the Monitor to the Network	1.19
Connecting the HIT-100 Hyper Isolation Transformer.....	1.20
Connecting the QI-320PA or QI-420PA Wireless LAN Station	1.20
Turning the Power On/Off	1.21
Check Before Turning On the Power	1.21
Turning the Power On.....	1.21
Check After Turning On the Power and During Monitoring.....	1.23
Stored Data Status at Power On	1.23
Monitor Status on Power Interruption.....	1.23
Turning the Power Off.....	1.24
Check After and Before Turning the Power Off.....	1.24
Setting the Bar Code Reader	1.25
Scanning the Bar Code Reader Settings	1.25
Initializing the Bar Code Reader.....	1.26
Checking the Bar Code Reader Operation.....	1.26
Calibrating the Touch Screen.....	1.27
Using ECG/BP Output as the Synchronous Signal	1.28
Administrator's Guide BSM-6000	1.1

1. INSTALLATION/CONNECTION

This section describes installation conditions, connecting cables and power cords and check items for this bedside monitor.

For simplicity, the suffix A/G/K will be omitted in this manual. There is no difference in operation among models with different suffixes unless otherwise specified.

Installation Conditions

Note the following points for the installation location of your bedside monitor.

WARNING

- Do not install the monitor and optional units above the patient.
- Only use the specified tools or equipment when installing the monitor and units. Failure to follow this warning may result in the monitor or unit falling and injuring the patient.

CAUTION

Only use the specified stand, cart or equipment for installing the monitor and instruments. Using non-specified equipment may result in the instruments falling and causing injury.

CAUTION

When not using the specified cart, carefully set the monitor to prevent it from falling off or tipping over.

- Install the monitor where you can see the monitor screen clearly.
- Install the monitor on a strong shelf or dedicated cart (option). Secure the monitor to the shelf to prevent it from falling.
- When moving a cart with a monitor, avoid collision. Strong impact may damage the monitor.
- The monitor is not intended to be used in an ambulance. The monitor might not function properly in a moving vehicle.
- The display screen is made of glass. Strong impact may damage it.
- Avoid locations where the monitor is sprinkled with liquid. Avoid direct sprinkling, spray or moist air from a nebulizer or a humidifier.
- Avoid exposing the monitor to direct sunlight.

- Make sure that there is at least 5 cm of space between the monitor and the wall for adequate ventilation. When the monitor is surrounded on all sides, make sure that there is about 10 cm of space above the monitor for ventilation so that the operating temperature does not exceed 40°C (104°F).

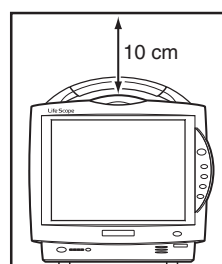
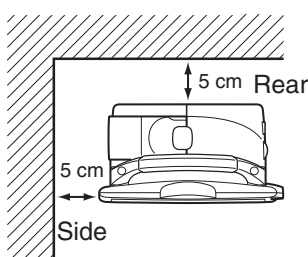

- Do not cover the monitor with a blanket or cloth. It may affect monitoring.
- Do not install the monitor in a dusty area.
- Connect the power cord to an AC outlet which can supply enough AC current to the monitor. The monitor cannot function properly with low current.
- When there is any problem on the monitor, turn off the power immediately and disconnect the power cord from the AC outlet. Take the monitor out of service and check for damage.

Optional Cart for the Bedside Monitor

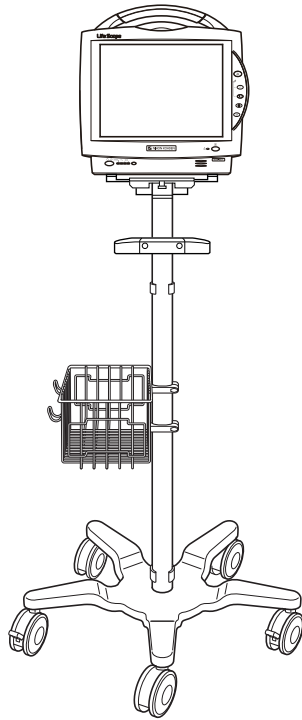

The KC-600P cart is available for installing the monitor. For details on how to use the cart, refer to the KC-600P cart installation guide.

CAUTION

Only use the specified stand, cart or equipment for installing the monitor and instruments. Using non-specified equipment may result in the instruments falling and causing injury.

CAUTION

When not using the specified cart, carefully set the monitor to prevent it from falling off or tipping over.

Optional Wall Mount Kit and Counter Top Mount for the Bedside Monitor

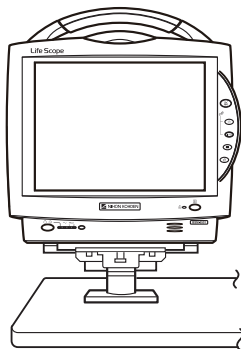

KG-600P counter top mount

For mounting the monitor on a wall, the KG-951P wall mount kit is available. For mounting the monitor on a shelf or table, the KG-600P counter top mount is available.

For details on how to use the wall mount kit or counter top mount, refer to the installation guide of the KG-951P wall mount kit or KG-600P counter top mount.

Installation Flowchart

You may not need to do all these.

1. Install the monitor. Refer to Section 1 in this manual.
2. Prepare the battery pack, remote control and recorder. Refer to Operator's Manual or Section 2 of the User's Guide Part I.
3. Check or change any initial settings on the SYSTEM CONFIGURATION screen. Changing these settings during monitoring interrupts monitoring. Refer to Section 2 in this manual.
4. Check or change any initial settings on the SYSTEM SETUP window. These settings are password protected settings which only an administrator can change. Refer to Section 3 in this manual.
5. Check or change the necessary settings before monitoring. Refer to Operator's Manual or Section 3 of the User's Guide Part I.
 - Date and time
 - Sound volume
 - Screen brightness
 - Waveform display settings
6. Enter the information of the new patient. Refer to "Admitting/Discharging Patient" in Operator's Manual or Section 3 of the User's Guide Part I.
7. Check or change all alarm items for the patient. The alarm returns to this master setting when:
 - The monitor power is off for more than 30 minutes and <SHOW ADMIT CONFIRMATION WINDOW> is turned off in the SYSTEM CONFIGURATION screen.
 - The patient is admitted or discharged.Refer to Operator's Manual or Section 5 of the User's Guide Part I.
8. Check or change settings for the review windows, such as trendgraphs, tables and arrhythmia recall files. Refer to Operator's Manual or Section 6 of the User's Guide Part I.
9. Check or change recording settings. Refer to Operator's Manual or Section 10 of the User's Guide Part I.
10. Prepare the equipment (electrodes, transducers, probes, etc.) for monitoring individual parameters and check or change the settings for each parameter. Refer to Operator's Manual or User's Guide Part II.

Installing the Optional Units to the Monitor and Connecting External Instruments

WARNING

Connect only the specified instrument to the monitor and follow the specified procedure. Failure to follow this warning may result in electrical shock or injury to the patient and operator, and cause fire or instrument malfunction.

WARNING

When several medical instruments are used together, ground all instruments to the same one-point ground. Any potential difference between instruments may cause electrical shock to the patient and operator.

CAUTION

Before connecting or disconnecting instruments, make sure that each instrument is turned off and the power cord is disconnected from the AC socket. Otherwise, the patient or operator may receive electrical shock or injury.

NOTE

- For details on connecting an external instrument to the monitor, contact your Nihon Kohden representative.
- Leakage current may increase when interconnecting many medical instruments to the monitor.
- Upgrade the main unit and each optional unit to the Nihon Kohden recommended software version. Only use the specified configuration of units. If more than one BSM-6000 series bedside monitor is used in the same facility, make sure the bedside monitors have the same software version. If BSM-6000 series monitors with different software versions are used together, correct system operation cannot be guaranteed.

Additional Safety Measures for Connecting External Instruments

When more than one electrical instrument is used, there may be electrical potential difference between the instruments. Potential difference between instruments may cause current to flow to the patient connected to the instruments, resulting in electrical shock. Never use any medical equipment in patient treatment without proper grounding.

Always perform equipotential grounding as specified in IEC 60601-1-1 when required. It is often required in the operating room, ICU room, CCU room, cardiac catheterization room and X-ray room. Consult with a biomedical engineer to determine if it is required.

Refer to the reference “General Requirements for Connecting Medical Electrical Systems” in Section 4.

1. INSTALLATION/CONNECTION

Environment for External Instruments

Use external instruments in the following environment.

When a JA-690PA/JA-694PA data acquisition unit is not connected to the bedside monitor

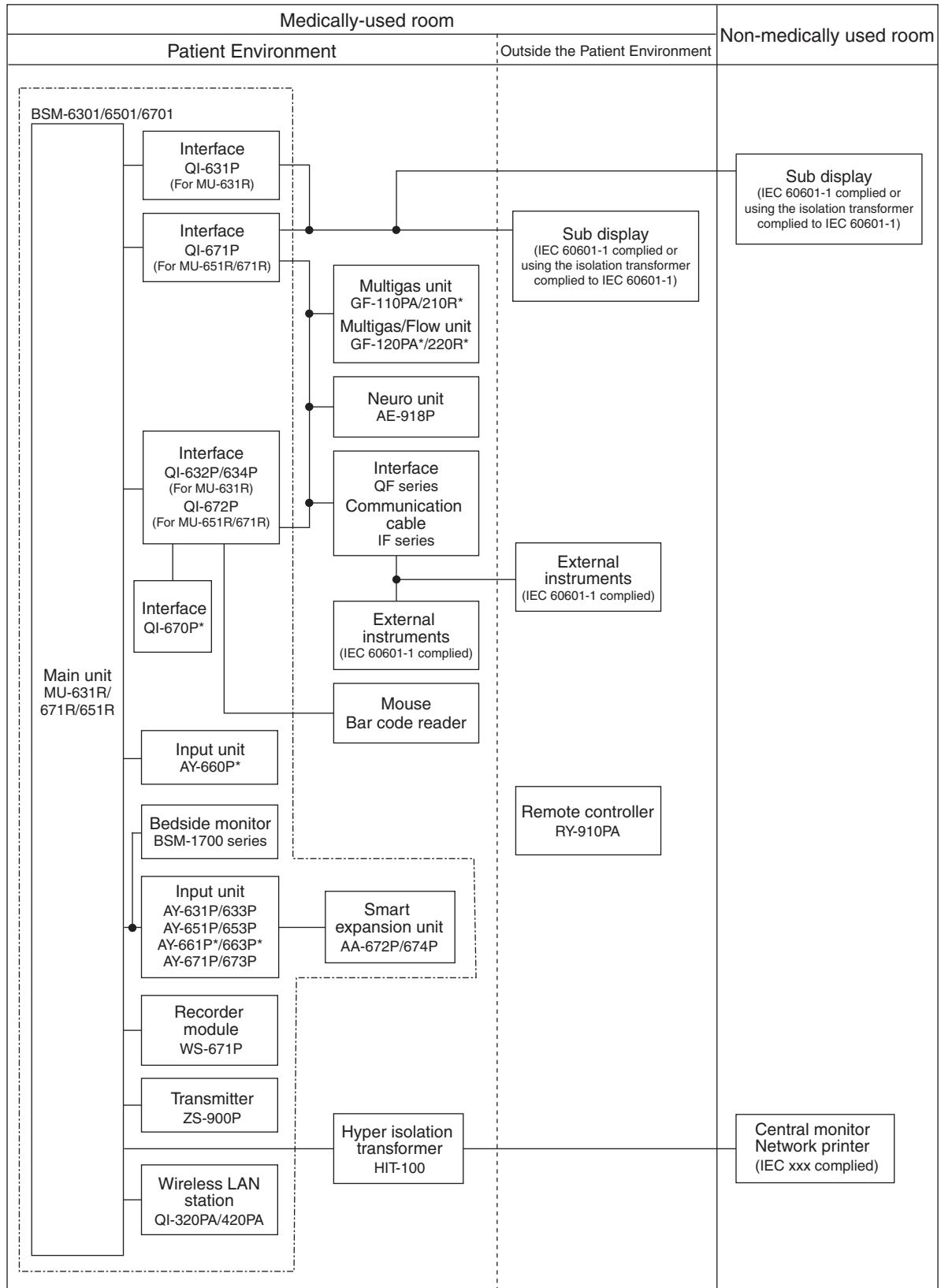

* These units are not available for BSM-6000A series.

When a JA-690PA/JA-694PA data acquisition unit is connected to the bedside monitor

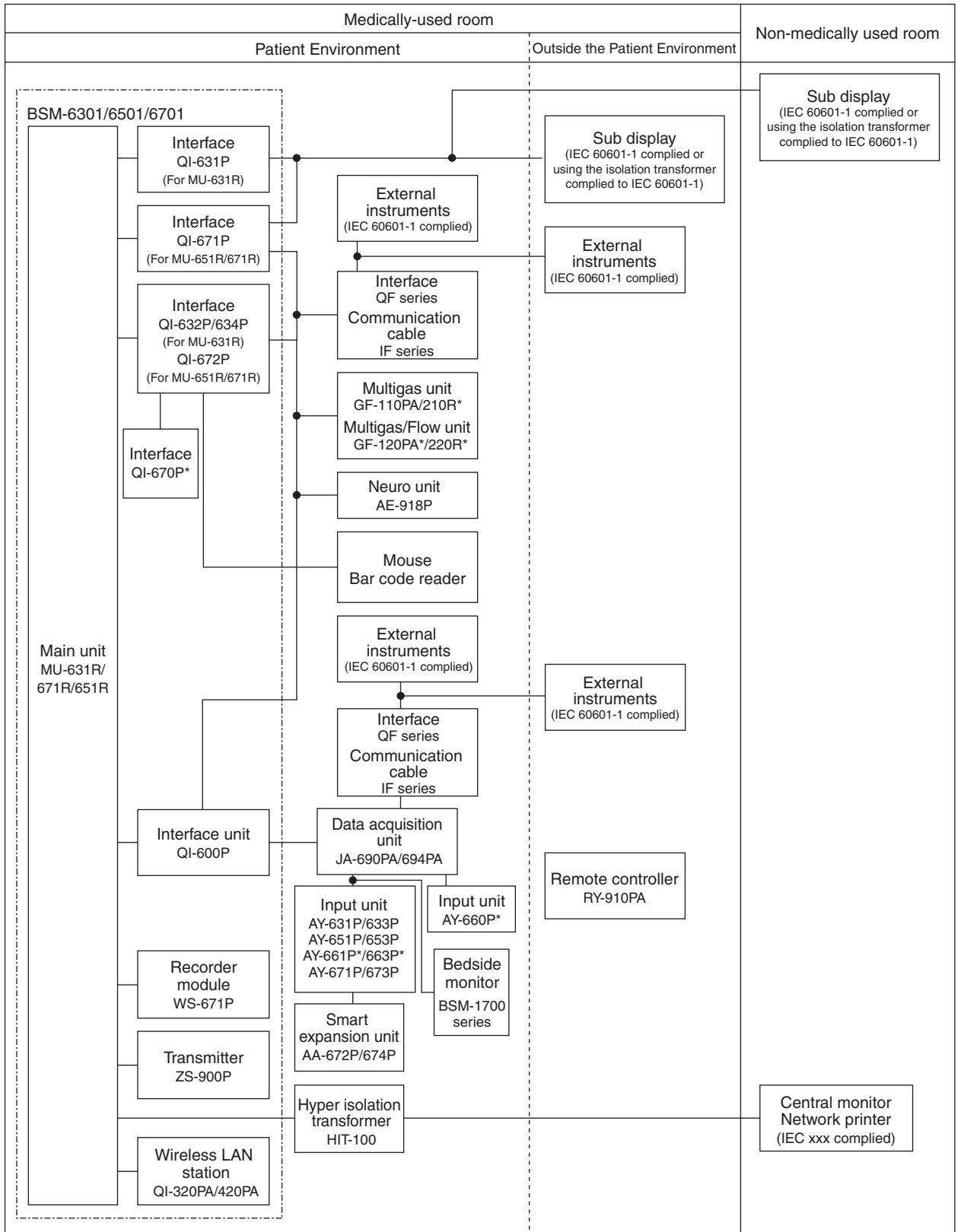

* These units are not available for BSM-6000A series.

1. INSTALLATION/CONNECTION

Connection Overview

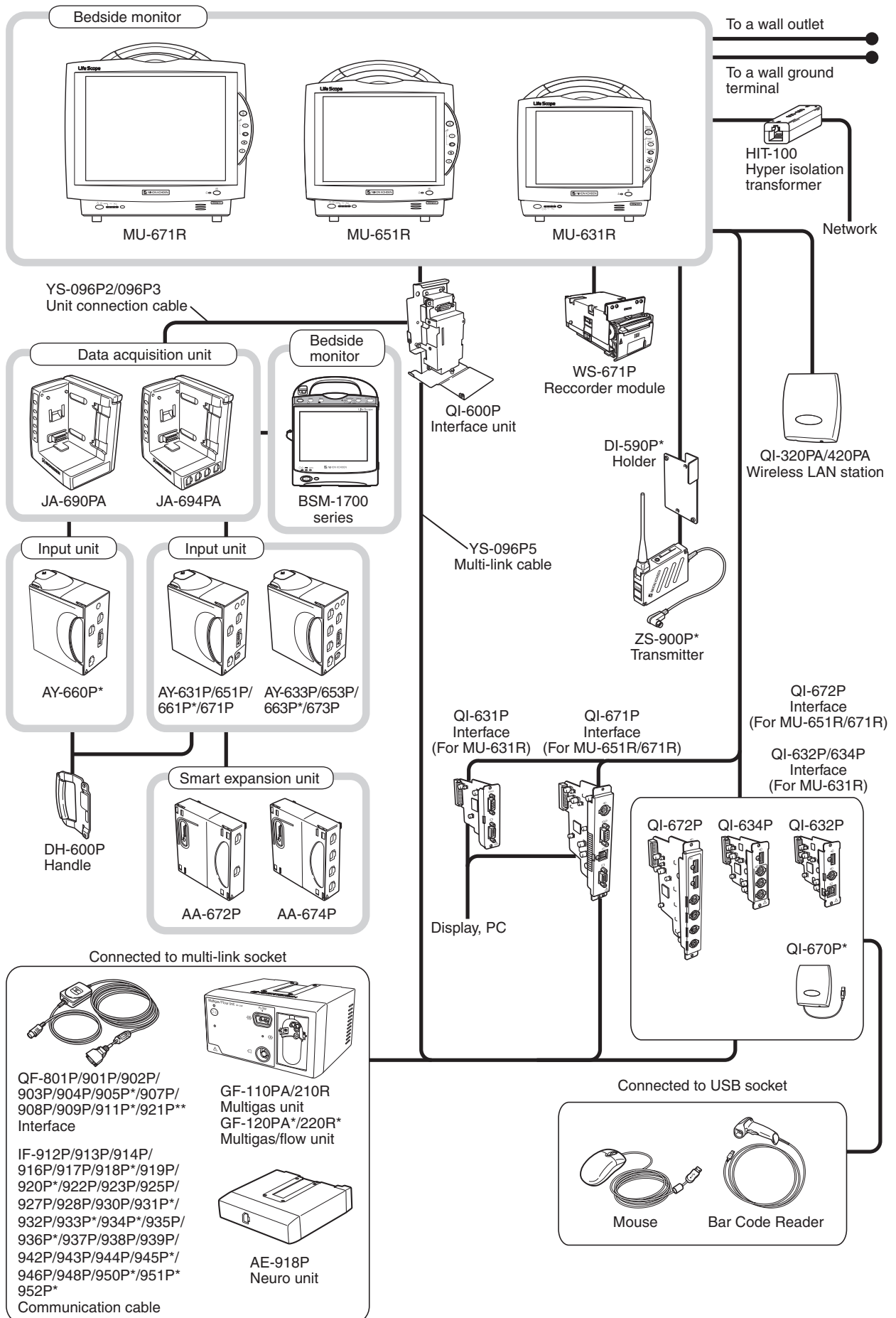

* Not available for BSM-6000A series.
** Not available for BSM-6000K series.

Attaching the AA-672P or AA-674P Smart Expansion Unit to the AY series Input Unit

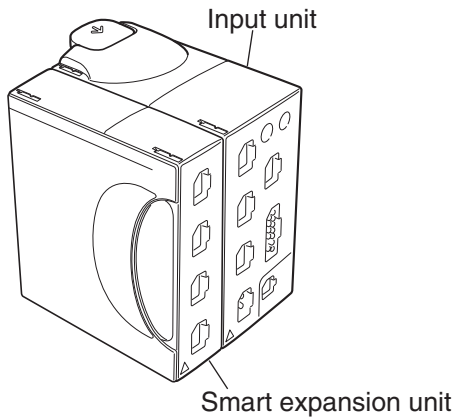

Attach the smart expansion unit to the input unit before mounting the input unit onto the monitor. Only one smart expansion unit can be attached to the input unit. For details on how to attach the smart expansion unit, refer to the manual provided with the unit.

NOTE

The AA-672P or AA-674P smart expansion unit does not function when it is attached to the AY-660P input unit.

Mounting the AY series Input Unit or BSM-1700 series Bedside Monitor onto the Monitor

The following procedure is for mounting the AY series input unit. For details on mounting the BSM-1700 series bedside monitor, refer to the BSM-1700 series bedside monitor operator's manual.

1. Mount the input unit onto the rear of the monitor so that the tabs on the input unit go into the slots on the monitor.

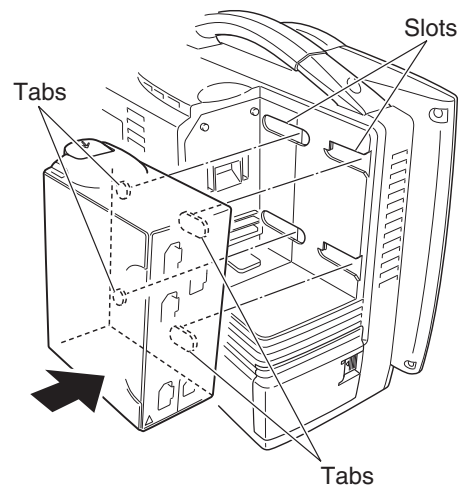

2. Slide the input unit in the direction of the arrow until it clicks into place.

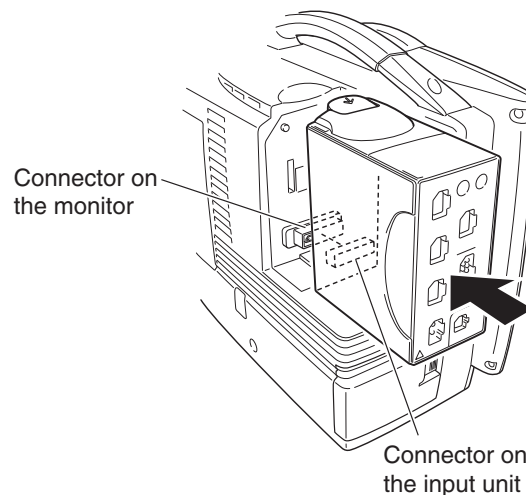

1. INSTALLATION/CONNECTION

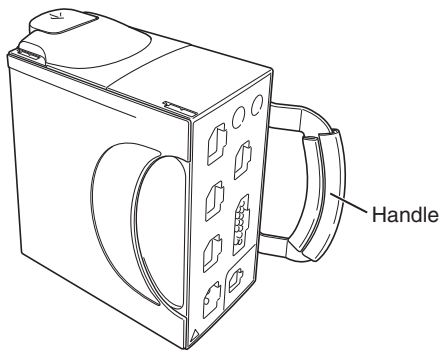

Using an Optional Handle

A DH-600P handle can be attached to the input unit so that the input unit can be removed from the main unit and carried around easily. For details on the handle, refer to the manual provided with the handle.

Attaching the ZS-900P Transmitter

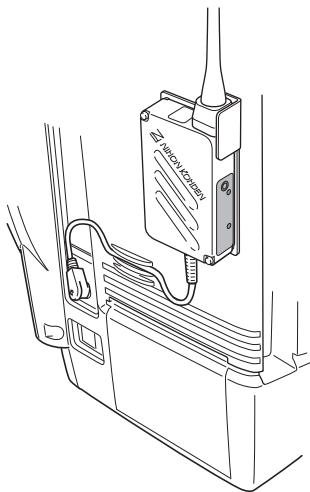

ZS-900P transmitter and DI-590P holder are not available for BSM-6000A series.

The ZS-900P transmitter transmits data from the monitor to a cardiac telemetry system or central monitor. A multiple patient receiver is necessary with the central monitors.

To connect the transmitter to the monitor, the optional DI-590P holder is required. Connect the transmitter to the monitor by referring to the DI-590P holder installation guide.

When the transmitter is connected to the monitor, turn the monitor power on and check that the LED on the transmitter lights in green. Also check that the channel number displayed in the upper part of the screen is correct.

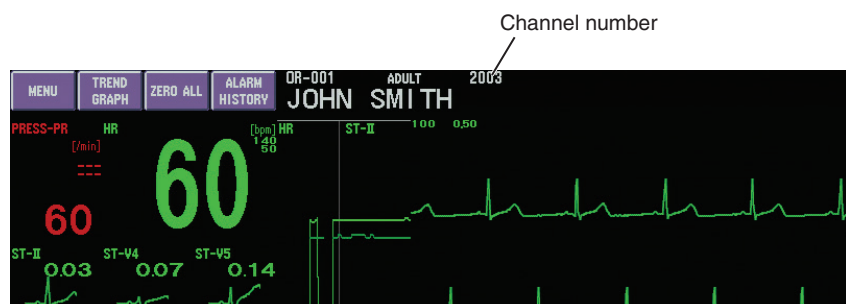

CAUTION

When using a ZS-900P transmitter, the measurement values and displayed waveform on the bedside monitor and receiving monitor may differ due to timing delay of the display and other factors. Be careful when reading the value and waveform.

CAUTION

When the ZS-900P transmitter is attached to the bedside monitor, check the alarm, arrhythmia and monitoring settings on the central monitor or telemetry system. The transmitter does not transmit the alarm, arrhythmia and monitoring setting information.

CAUTION

The ZS-900P transmitter can only transmit temperature data from 5 to 45°C (41 to 113°F). Be careful when reading the value.

CAUTION

When transmitting CO₂ data through a ZS-900P transmitter to a receiving monitor, if the transmitted CO₂ data is out of the range of the receiving monitor, the maximum value of the receiving monitor is displayed instead. Be careful when reading the value.

NOTE

- Before connecting the transmitter, turn off the monitor power.
- The ZS-900P transmitter does not comply with the CE mark.
- A ZB-800P or ZB-900P transmitter cannot be used on this monitor.

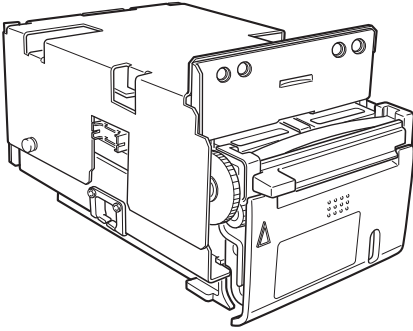
Installing the WS-671P Recorder Module

Install the optional WS-671P recorder module in the monitor by referring to the WS-671P recorder module installation guide. To load the recording paper, refer to Operator's Manual or Section 2 of the User's Guide Part I.

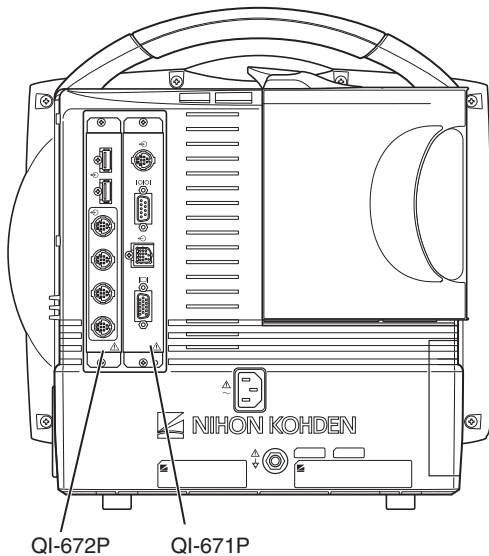
Installing the QI-631P, QI-632P, QI-634P, QI-671P or QI-672P Interface

When the interface is installed in the monitor, external instruments can be connected to the monitor.

The illustration on the left shows both the QI-671P and QI-672P interfaces are installed in the BSM-6701 bedside monitor.

The interface has 2, 3, 4 or 6 sockets.

For BSM-6301:

- QI-631P: RS-232C, RGB
- QI-632P: USB, multi-link, alarm signal output
- QI-634P: USB, multi-link

For BSM-6501 and BSM-6701:

- QI-671P: Multi-link, RS-232C, alarm signal output, RGB
- QI-672P: 2 USB, 4 multi-link

Install the optional interface in the monitor by referring to the manual provided with the interface.

1. INSTALLATION/CONNECTION

Connecting the Mouse

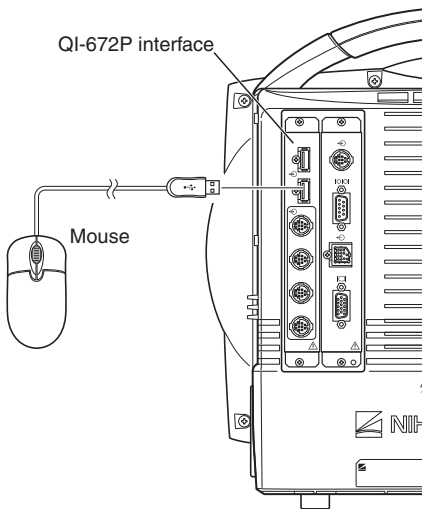

To connect the mouse, the QI-632P, QI-634P or QI-672P interface is required. The QI-632P and QI-634P interfaces are for BSM-6301. The QI-672P interface is for BSM-6501 and BSM-6701.

The illustration on the left shows both the QI-672P and QI-671P interfaces are installed in the BSM-6701 bedside monitor.

Connect the mouse cable to the USB socket on the interface which is installed in the monitor.

Connecting the Bar Code Reader

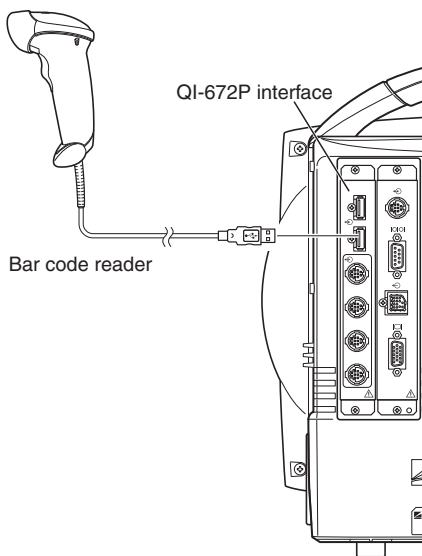

To connect the bar code reader, the QI-632P, QI-634P or QI-672P interface is required. The QI-632P and QI-634P interfaces are for BSM-6301. The QI-672P interface is for BSM-6501 and BSM-6701.

The illustration on the left shows both the QI-672P and QI-671P interfaces installed in the BSM-6701 bedside monitor.

Connect the bar code reader cable to the USB socket on the interface which is installed in the monitor.

Refer to “Setting the Bar Code Reader” later in this section for setting the bar code reader.

Mounting the QI-670P Interface on the Monitor

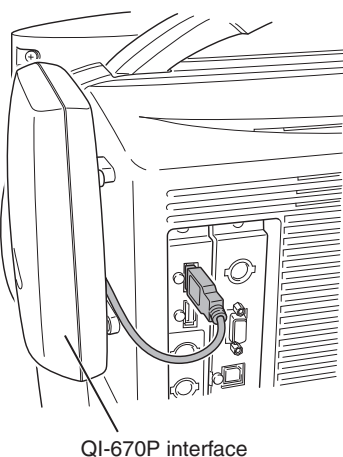

When the QI-670P interface is mounted on the monitor, waveforms and numeric data can be received from a TEC-5600 series or TEC-8300 series defibrillator. Mount the optional interface onto the monitor by referring to the manual provided with the interface.

Connecting the JA-690PA or JA-694PA Data Acquisition Unit

To connect the JA-690PA or JA-694PA data acquisition unit, the YS-096P2 or YS-096P3 unit connection cable is required. Connect the cable to the bedside monitor and to the unit connection socket on the data acquisition unit.

For details on how to use the data acquisition unit, refer to the data acquisition unit operator's manual.

NOTE

- Connect the unit connection cable to the unit connection socket on the data acquisition unit straight until it locks firmly.
- Keep the cable out of the way by running it along the floor or wall. Otherwise people may trip over it, causing the instrument to fall and injure the patient and operator.

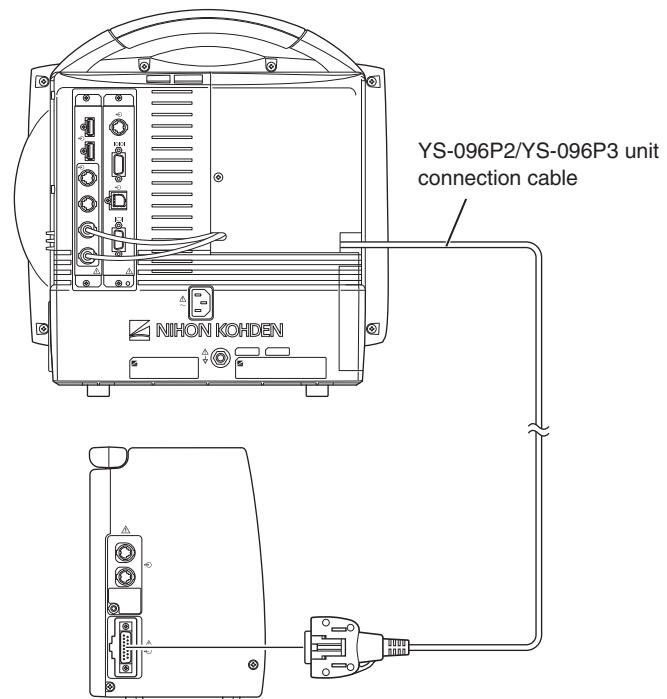

Connecting External Instruments

To connect the external instruments, the QI-632P or QI-634P interface for BSM-6301 or QI-671P or QI-672P interface for BSM-6501 and BSM-6701 must be installed in the monitor.

Connecting a GF-110PA or GF-210R Multigas Unit, GF-120PA or GF-220R Multigas/Flow Unit or AE-918P Neuro Unit

NOTE

GF-120PA and GF-220R multigas/flow units are not available for the BSM-6000A series.

Connect the GF-110PA or GF-210R multigas unit, GF-120PA or GF-220R multigas/flow unit or AE-918P neuro unit to one of the multi-link sockets on the QI-632P, QI-634P, QI-671P or QI-672P interface.

NOTE

When a multigas unit or multigas/flow unit is connected to the monitor and the monitor is in operation, do not connect any other instrument to the monitor with a multi-link cable. If another multi-link cable is connected to the main unit during operation, the multigas unit or multigas/flow unit may enter warmup status and automatically restart monitoring 45 seconds (AG-920R, GF-110PA, GF-120PA) or 6 minutes (GF-210R, GF-220R) after warmup.

The following example shows both the QI-671P and QI-672P interfaces installed in the BSM-6701 bedside monitor and a GF-120PA multigas/flow unit connected.

Connecting Example

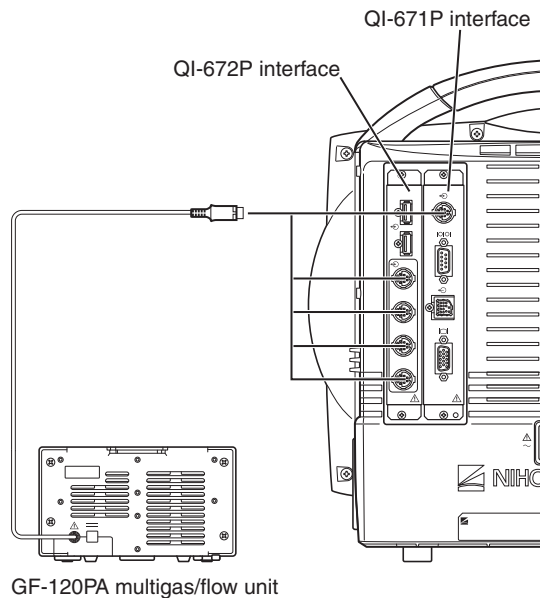

Connecting an External Instrument Using a QF series Interface or IF series Communication Cable

Connect the QF series interface cable or IF series communication cable to the external instrument and to one of the multi-link sockets on the QI-632P, QI-634P, QI-671P or QI-672P interface.

The following example shows both the QI-671P and QI-672P interfaces installed in the BSM-6701 bedside monitor.

NOTE

Do not connect or remove the QF series interface or IF series communication cable connector while the monitor power is on. The monitor might not function properly.

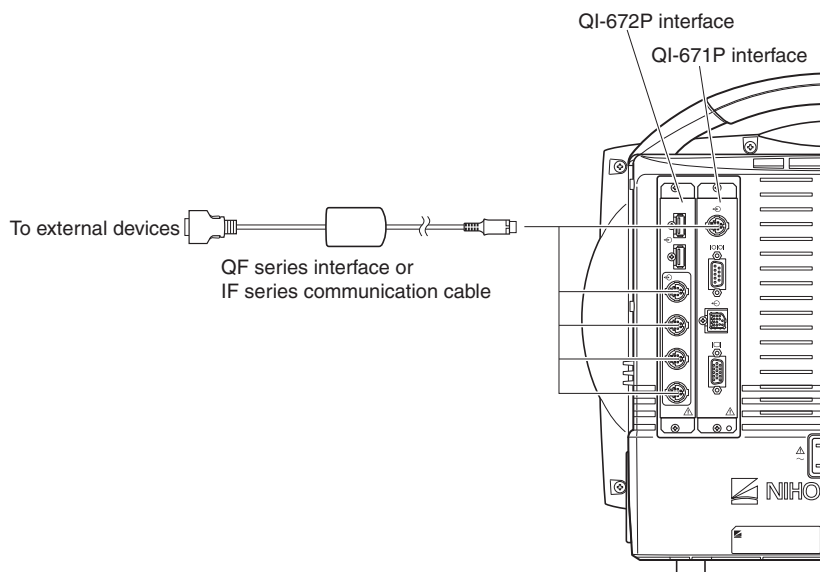

Connecting a Sub Display

A sub display can be connected to the bedside monitor. Connect the sub display to the RGB socket on the QI-631P interface for a BSM-6301 bedside monitor or to the QI-671P interface for a BSM-6501 or BSM-6701 bedside monitor. The sub display must meet the following specifications. An NEC LCD191VXM or equivalent display is recommended.

Minimum specifications for BSM-6701 display:

- Resolution: 1024 × 768
- Input Analog RGB: 0.7 Vp-p
- V-sync: 60.0 Hz
- H-sync: 48.4 kHz

Minimum specifications for BSM-6301 and BSM-6501 display:

- Resolution: 800 × 600
- Input Analog RGB: 0.7 Vp-p
- V-sync: 60.3 Hz
- H-sync: 37.9 kHz

1. INSTALLATION/CONNECTION

To connect the display to the interface, use the YS-080P3 RGB cable (10 m). The sub display must be connected to the SM-800R isolation transformer.

The screen to be displayed on the sub display can be set to either of the following on the DISPLAY page of the SYSTEM SETUP window. Refer to Section 3.

- SLAVE: Same screen as the bedside monitor.
- HOME SCREEN: The home screen is always displayed.

Connecting the Power Cord and Grounding Lead

General

The monitor can operate on either battery or AC power.

When the power cord is plugged into an AC outlet and the power switch on the front panel is turned on, the monitor operates on AC power.

When a battery pack is inserted and the power cord is disconnected or there is a sudden power failure, the monitor automatically switches to battery power.

The battery pack is charged when the power cord is plugged into an AC outlet and the AC current is supplied to the monitor. The battery pack is also charged during monitoring.

The monitor can operate for about 90 minutes on the BSM-6301 and BSM-6501 or about 60 minutes on the BSM-6701 with a new fully charged battery pack when:

- Used in normal temperature.
- Recorder is stopped.
- No alarm occurs.
- Monitoring ECG, respiration (impedance) and SpO₂.
- <POWER SAVING MODE> on the SYSTEM SETUP window is set to ON.
- <SYNC SOUND VOLUME> on the VOLUME window is set to OFF.
- NIBP measurement interval is 15 minutes.
- QI-671P and QI-672P interfaces or QI-631P and QI-632P or QI-634P interfaces are installed in the monitor.
- The input unit is an AY-600P series input unit and not a BSM-1700 series bedside monitor.

Connecting the Power Cord

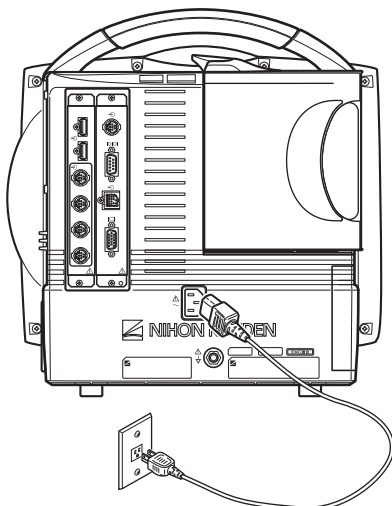

WARNING

Only use the provided power cord. Using other power cords may result in electrical shock or injury to the patient and operator.

Connect the provided power cord to the AC SOURCE socket on the rear panel of the monitor and plug the cord into a 3-prong AC outlet.

1. INSTALLATION/CONNECTION

When AC power is supplied to the monitor, the AC power lamp on the front panel lights.

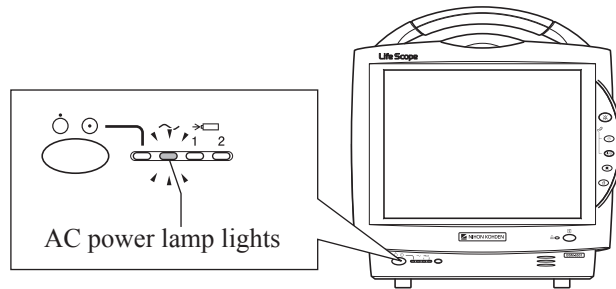

NOTE

If the AC power lamp does not light, check the power cord connection.

Grounding the Monitor

WARNING

When several medical instruments are used together, ground all instruments to the same one-point ground. Any potential difference between instruments may cause electrical shock to the patient and operator.

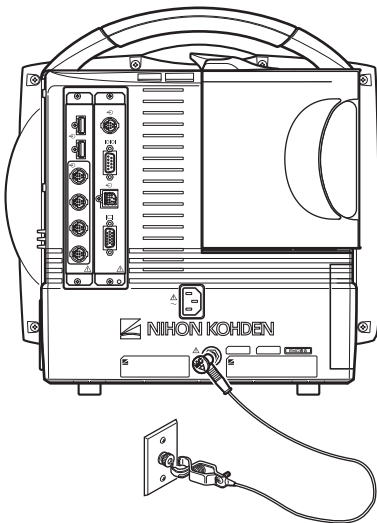

When more than one electrical instrument is used, there may be electrical potential difference between the instruments. The potential difference between the instruments may cause current to flow to the patient connected to the instruments, resulting in electrical shock.

Always perform equipotential grounding when required. It is often required in the operating room, ICU room, CCU room, cardiac catheterization room and X-ray room. Consult with a biomedical engineer to determine if it is required.

When equipotential grounding is required, connect the equipotential ground terminal on the instrument to the equipotential ground terminal on the wall (equipotential grounding system) with the equipotential grounding lead (potential equalization conductor).

Cutting Off the Power Supply to the Monitor

To cut off the power supply to the monitor, disconnect the power cord of the monitor from the wall AC outlet. When installing the monitor, position the monitor so that it is easy to disconnect the power cord from the wall AC outlet.

Connecting the Monitor to the Network

The network connection method differs according to the installation location of the monitor and the network components. The network connection must comply with IEC 60601-1-1 “General Requirements for Safety of Medical Electrical Equipment”. For details, refer to the “Network and System Installation Guide” which is available from your Nihon Kohden representative.

WARNING

Connect the monitor to network as specified. Otherwise the patient and operator may receive electrical shock or injury. To connect the network, contact your Nihon Kohden representative.

WARNING

In a network where this monitor is connected, connect only the specified instruments. Unspecified instruments may cause electrical shock or injury to the patient and operator or cause instrument malfunction, instrument stop, or data loss.

WARNING

Install all network devices, including printer and hubs, outside the patient environment (IEC 60601-1-1). If they are installed inside the patient environment, the patient or operator may receive electrical shock or injury. For installation, contact your Nihon Kohden representative.

WARNING

Check the software version number of the monitor before connecting it to the network. Different software versions have different communication methods. More than one communication method in a network may cause communication failure. For details, refer to the Network and System Installation Guide.

Connecting the HIT-100 Hyper Isolation Transformer

Connect the monitor to the network with the specified LAN cable. Connect the HIT-100 hyper isolation transformer between the monitor and network.

WARNING

Do not use a damaged network cable. The patient or operator may receive electrical shock when the damaged part is touched.

NOTE

The time on this monitor is automatically adjusted to match the time of the network as long as the monitor is connected to the network. The date and time on all monitors in the network are set to the same setting.

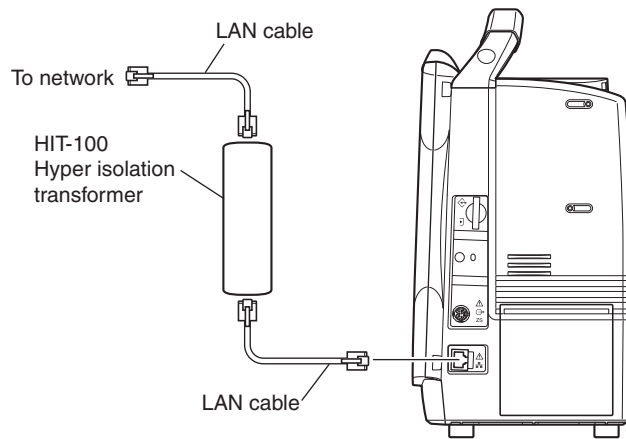

Connecting the QI-320PA or QI-420PA Wireless LAN Station

Connect the QI-320PA or QI-420PA wireless LAN station to the bedside monitor with a specified wireless LAN access point. Refer to the QI-320PA or QI-420PA wireless LAN station operator's manual.

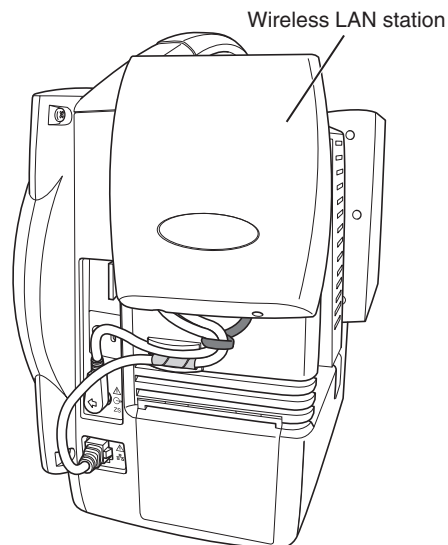

Turning the Power On/Off

Check Before Turning On the Power

Check the following items before turning on the power.

- Enough electrodes and electrode leads are ready.
- Cleaned and sterilized sensors and transducers are ready.
- Power cord is connected properly.
- Equipotential grounding lead is connected properly when equipotential grounding is required.
- All cables are connected properly.
- Enough recording paper in the recorder (when using an optional recorder).
- Fully charged battery pack is installed in the monitor in case of a sudden power failure.
- No scratches, damage or dirt on the monitor.
- No damage to the keys and panels.
- No damage to the power cord.
- No damage to the electrode leads, transducers, probes and cables.
- The monitor is not in a wet place.

Turning the Power On

CAUTION

Do not turn the monitor off when the system check screen is displayed. Otherwise the saved data may be damaged or deleted. If the monitor is turned off during system check, delete all data because the data is not reliable.

NOTE

- It takes a few minutes for the LCD screen to reach full brightness.
- The shadow of the previous screen may remain for a few minutes after changing screens.
- There may be some dots on the LCD screen which are always on or always off, but it does not affect monitoring. This is normal for all LCD screens.
- Even though the position of symbol marks for the lamps are different on BSM-6301 and BSM-6501 or BSM-6701, the function and the position of lamps are the same.

1. INSTALLATION/CONNECTION



Press the [power] switch on the front panel to turn the power on. The power lamp and the AC power lamp light and self check starts. When the check is complete, the home screen appears.

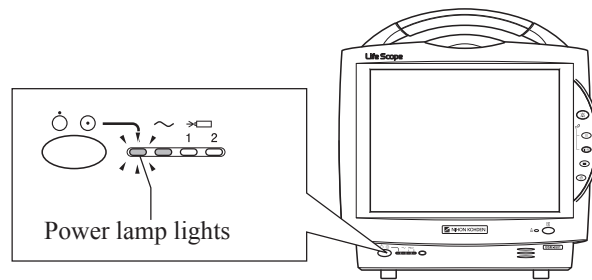

If the power lamp does not light, check the power cord connection.

The power can also be turned on by pressing the [POWER] button on the remote control.

CAUTION

When the monitor is turned on, check that a single beep sounds and the red, yellow, cyan and green alarm indicator lamps blink once. This shows that the alarm is functioning properly.

When the monitor power is turned on, alarms are suspended while the monitor is waiting for the electrodes and probe to be attached to the patient. The monitoring starts when the connection cord is connected to the socket on the monitor and the electrodes or probe are attached to the patient. The alarm activates when one of the following occurs:

- ECG, SpO₂ or IBP is monitored or NIBP is measured and a value is displayed (when AUTO is selected for <ALARM ACTIVATION DELAY> on the ALARM window of the SYSTEM SETUP window).
- ECG, SpO₂ or IBP is continuously monitored for the selected time (when 1 min, 2 min or 3 min is selected for <ALARM ACTIVATION DELAY>).
- NIBP is measured (when 1 min, 2 min or 3 min is selected for <ALARM ACTIVATION DELAY>).

Check After Turning On the Power and During Monitoring

To start monitoring safely and properly, check the following items after turning on the power. If any problem is detected, take the proper countermeasure according to the troubleshooting and maintenance sections.

- There is no fire, smoke or smell.
- The monitor is not too hot.
- The power lamp and other lamps light.
- The red, yellow, cyan and green alarm indicator lamps blink once and a beep sounds.
- The start up screen appears and the home screen appears.
- No error message is displayed on the screen.
- The time on the screen is correct.
- The monitor does not affect surrounding equipment.
- The data and waveforms are displayed properly.
- Keys and switches operate properly.
- The touch keys function properly and the key clicking sound is generated.
- Alarm functions properly.
- Alarm sound can be heard.
- Alarm sound volume setting is appropriate.
- There is no trouble in recording (when using an optional recorder).

NOTE

After turning the monitor on and when admitting a patient on the monitor, make sure that the time displayed at the upper right of the screen is correct. When the date or time is changed during monitoring, the date and time of all stored data is also changed and might not match the date and time on the printout.

When the monitor is connected to a network

The time on this monitor is automatically adjusted to match the time of the network as long as the monitor is connected to the network. The date and time on all monitors in the network are set to the same setting.

Stored Data Status at Power On

Stored data status at power on depends on the settings on the DATA MANAGEMENT window of the SYSTEM CONFIGURATION screen, whether the previous patient is discharged, and whether the power is off for more than 30 minutes. For details, refer to the Operator's Manual or Section 5 of the User's Guide Part I.

Monitor Status on Power Interruption

When there is a power failure or sudden power interruption, the monitor status is as follows.

- When a battery pack is installed in the monitor, the BSM-6301 and BSM-6501 operate for about 90 minutes and the BSM-6701 operates for about 60 minutes on battery power.

1. INSTALLATION/CONNECTION

- When the monitor has no battery pack installed or the battery pack is discharged, the monitor turns off. When the AC power is restored, the monitor turns on automatically. The patient data and settings are stored for about 30 minutes after power off when <DATA TRANSPORT USING INPUT UNIT> is set to DISABLE and <SHOW ADMIT CONFIRMATION WINDOW> is set to OFF in the SYSTEM CONFIGURATION screen.

When <DATA TRANSPORT USING INPUT UNIT> is set to ENABLE, the patient data and settings are always stored.

When there is a power failure or sudden power interruption, immediately connect the monitor to the emergency power source. It is recommended to always keep the battery pack in the monitor.

Turning the Power Off

NOTE

Even though the position of symbol marks for the lamps are different on BSM-6301 and BSM-6501 or BSM-6701, the function and the position of lamps are the same.



Press the [power] switch on the front panel for more than 3 seconds to turn the power off. The screen becomes dark and the power lamp on the front panel turns off.

The power can also be turned off by pressing the [POWER] button for more than three seconds on the remote control.

Check After and Before Turning the Power Off

Check the following items for the next use.

- Previous patient data is deleted.
- Temporarily changed settings are changed back to the previous settings.
- There is no dirt, damage or scratches on the monitor.
- The sensors, probes, transducers, and cables are cleaned and sterilized.
- Accessories are cleaned and stored properly.
- There are enough consumables, such as recording paper, and disposable electrodes for the next use.
- Battery pack is fully charged.
- The [power] switch on the monitor is turned off and the power cord is disconnected from the monitor.
- The monitor is not in a wet place.
- Dead batteries are disposed of properly.
- Medical waste is disposed of properly.
- The monitor is stored properly.

Setting the Bar Code Reader

Scanning the Bar Code Reader Settings

You can use the Symbol LS2208 from Motorola, Inc. Refer to the manual. You can download the manual from <http://support.symbol.com> on the Motorola website.

Following are the minimum settings of the bar code reader. Scan the following bar codes in order. When scanning the bar code, there is one short high beep. For further settings, refer to the Symbol LS2208 manual.

* This setting is a default value. You can skip scanning this bar code if you have already used this bar code reader with the default value.

Beeper Volume

Low Volume



USB Device Type

HID Keyboard Emulation*



USB Country Keyboard Types (Country Codes)

North American Standard USB Keyboard*



Transmit Code ID Character

None*



Scan Data Transmission Format

Scan Options



<DATA> <SUFFIX>



1. INSTALLATION/CONNECTION

Enter



Transmit “No Read” Message

Disable No Read*



Enable/Disable Codabar

Enable Codabar



Initializing the Bar Code Reader

Scanning this bar code returns all data to the default values. Scan the following bar code if you want to initialize the bar code reader.

Set All Defaults



Checking the Bar Code Reader Operation

Scan the bar code of the patient on the home screen or the PATIENT ID window of the ADMIT page in the ADMIT DISCHARGE window and check the patient ID is entered on the PATIENT ID window of the ADMIT page in the ADMIT DISCHARGE window.

Calibrating the Touch Screen

Calibrate the touch screen when the pressed position and the activated position do not match.

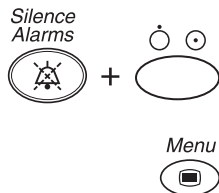

1. Turn the monitor power off.
2. Press the [power] switch while pressing the [Silence Alarms] key on the front panel until the DIAGNOSTIC CHECK screen is displayed.
3. Press the [Menu] key. The TOUCHPANEL CALIBRATION screen appears.

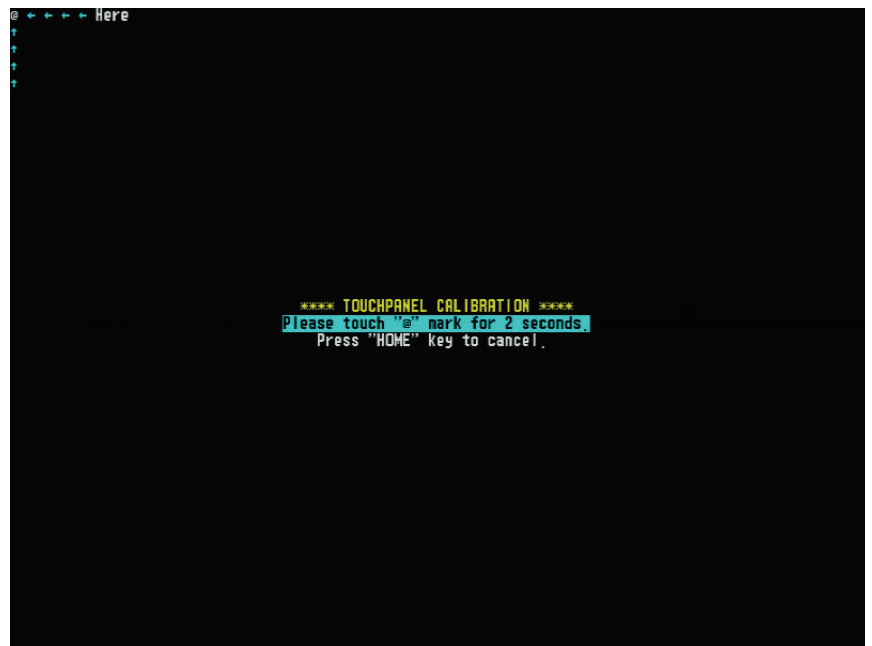

4. Touch the @ mark at the upper left corner of the screen for 2 seconds. When the mark is correctly touched, another mark appears in the lower right corner of the screen. Touch the mark for 2 seconds.

When the marks are touched correctly, the “TOUCHPANEL CALIBRATION SUCCEEDED” message appears, then the DIAGNOSTIC CHECK screen appears.

5. Touch the RETURN key to display the home screen.

Using ECG/BP Output as the Synchronous Signal

The ECG, IBP and heart rate pulse trigger output signal from the monitor can be used as the synchronizing signal on a medical electrical instrument, such as IABP equipment or defibrillator, which complies with IEC 60601-1.

When outputting the HT pulse signal, select the output polarity depending on an external instrument. Refer to “OTHER Window” in Section 2 for details.

CAUTION

When using the output signal from the monitor as the synchronization signal for other equipment such as an IABP (intra-aortic balloon pump) or defibrillator:

- Set the timing of the IABP by checking the waveform on the IABP screen.
- Check the condition of the bedside monitor at all times. The output signal may become unstable.
- Check that the delay time of the output signal is within the range of the connected equipment.

CAUTION

Only a Nihon Kohden defibrillator can use the output signal from the monitor as a synchronization signal. Check that the delay time of the output signal (heart rate trigger 20 ms maximum) is within the range of the connected defibrillator.

NOTE

- When using an IBP waveform as a synchronization signal for other equipment, connect the IBP line to the MULTI socket. The IBP waveform that is used for the synchronization signal depends on the “IBP ANALOG OUT” setting in the SYSTEM SETUP window.
 - When “IBP ANALOG OUT” is set to FIXED POSITION: The IBP line connected to the top MULTI socket is used.
 - When “IBP ANALOG OUT” is set to HIGHEST PRIORITY LABEL: When more than one IBP waveform is acquired, the IBP waveform of the highest priority label is used.

IBP label priority:
 ART > ART2 > RAD > DORS > AO > FEM > UA > LVP > P1 > P2 > P3 > P4 > P5 > P6 > P7
- The output signal from the ECG/BP OUT socket may become unstable in the following conditions.
 - Electrode is dry or detached.
 - Electrode lead is damaged or disconnected from the electrode.
 - Electrode lead is pulled.
 - AC interference or EMG noise superimposed.
 - Air bubbles or blood clog in the circuit for monitoring IBP.
 - Cord or cable is disconnected or damaged.

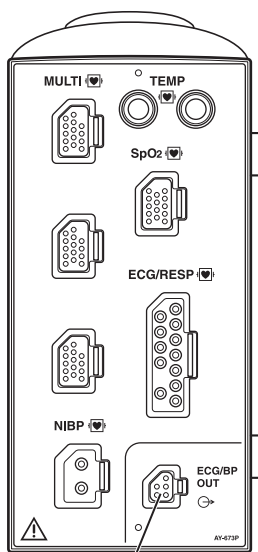

ECG/BP OUT socket
 Outputs 1 V/1 mV ECG, 1 V/100 mmHg BP and open collector heart rate trigger signals.

- All instruments which are to be connected to the ECG/BP OUTPUT socket must use a YJ-910P or YJ-920P ECG/BP output cable and comply with the IEC 60601-1 safety standard for medical equipment.
- When using an IABP, set <CALCULATION METHOD> on the OTHER page of the PRESS window to “PEAK” to improve measurement accuracy.
- The AY-660P input unit has no ECG/BP OUT socket and no signal can be output.

Connect the YJ-910P or YJ-920P ECG/BP output cable to the ECG/BP OUT socket and the external instrument.

The following shows the delay time of the output signal.

Output Signal	Delay Time
ECG	20 ms
BP	40 ms
Heart rate trigger	20 ms

Section 2 Changing SYSTEM CONFIGURATION Screen Settings

Overview.....	2.2
Setting Items on the SYSTEM CONFIGURATION Screen	2.2
Displaying the SYSTEM CONFIGURATION Screen	2.3
Closing the SYSTEM CONFIGURATION Screen	2.5
SITE Window	2.6
NETWORK Window.....	2.8
IP ADDRESS/PROTOCOL Page	2.8
LS-NET Page	2.9
HL7 Page	2.10
UNITS Window	2.12
DATA MANAGEMENT Window.....	2.13
PC Window	2.17
CHANGE PASSWORD Window	2.18
OPTIONS Window.....	2.19
OTHER Window	2.20
Initializing the Monitor.....	2.22

Overview

The section explains how to change settings on the SYSTEM CONFIGURATION screen.

The initial settings on the SYSTEM CONFIGURATION screen must be changed before monitoring. Changing these settings during monitoring interrupts monitoring. All other settings can be changed any time without interrupting monitoring. You can check the contents of the SYSTEM CONFIGURATION screen settings on the CONFIGURATION page of the SYSTEM SETUP window so that the monitor power does not need to be turned off and monitoring is not interrupted (refer to Section 3).

This section also explains how to initialize the monitor. This procedure returns all settings to the factory default settings and deletes all stored data in memory.

Setting Items on the SYSTEM CONFIGURATION Screen

SITE window

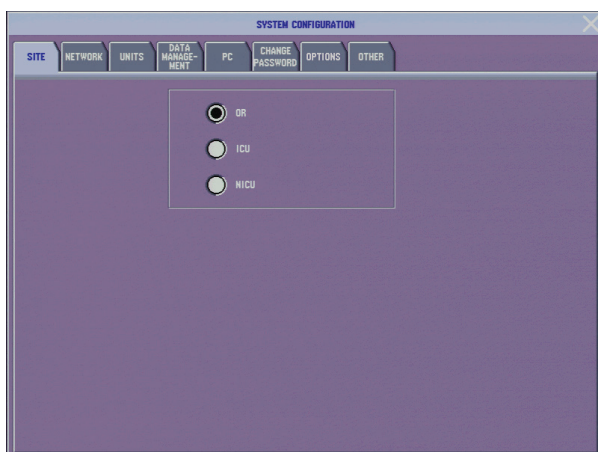

NETWORK window



HL7 tab is displayed only on BSM-6000K series.

UNITS window

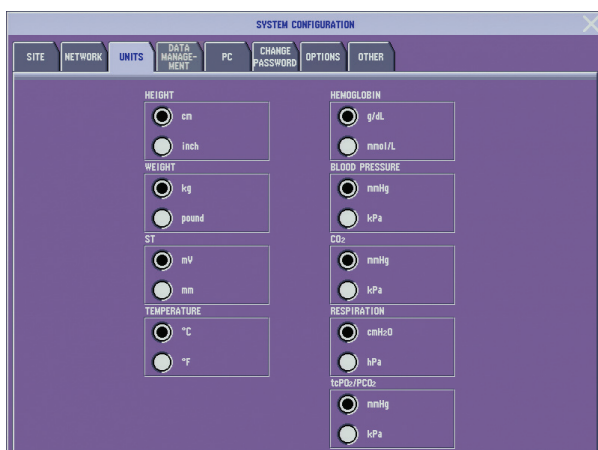

DATA MANAGEMENT window

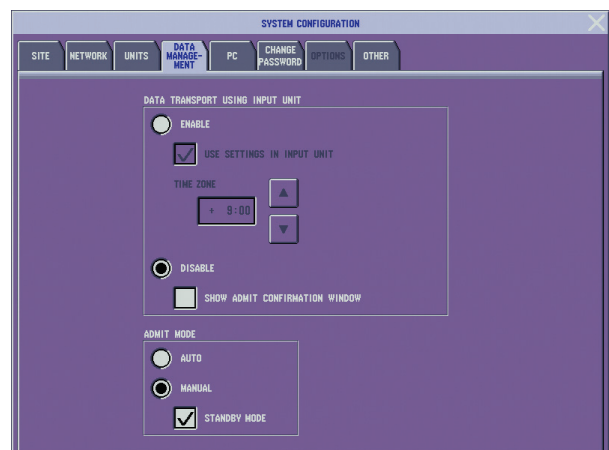

PC window

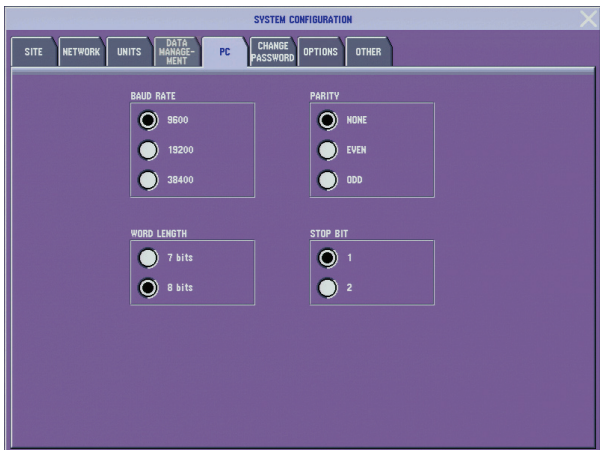

CHANGE PASSWORD window

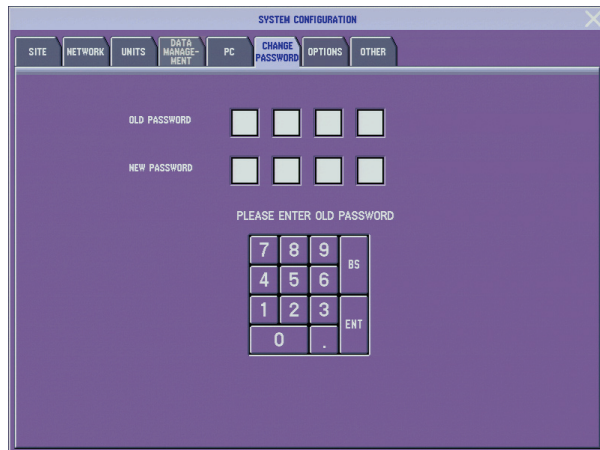

OPTIONS window

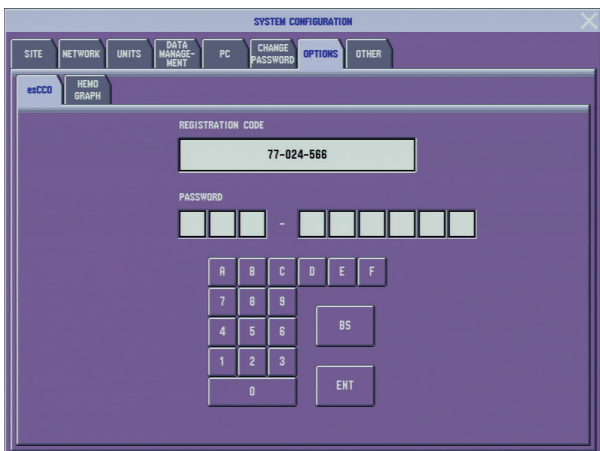

OTHER window

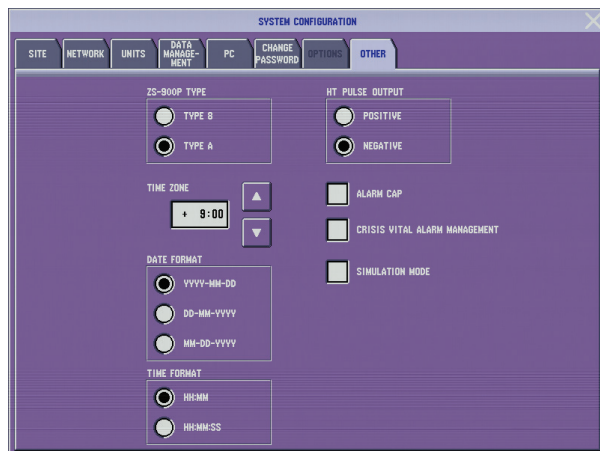

<ALARM CAP> and <CRISIS VITAL ALARM MANAGEMENT> are displayed only on BSM-6000A series.

Displaying the SYSTEM CONFIGURATION Screen

CAUTION
This procedure interrupts all monitoring. Only change these settings before or after monitoring.

1. Turn the monitor power off.
2. Press the [power] switch while pressing the [Silence Alarms] key on the front panel until the DIAGNOSTIC CHECK screen is displayed.



2. CHANGING SYSTEM CONFIGURATION SCREEN SETTINGS

3. Touch the SYSTEM CONFIG key. The dialog box to enter the password appears.

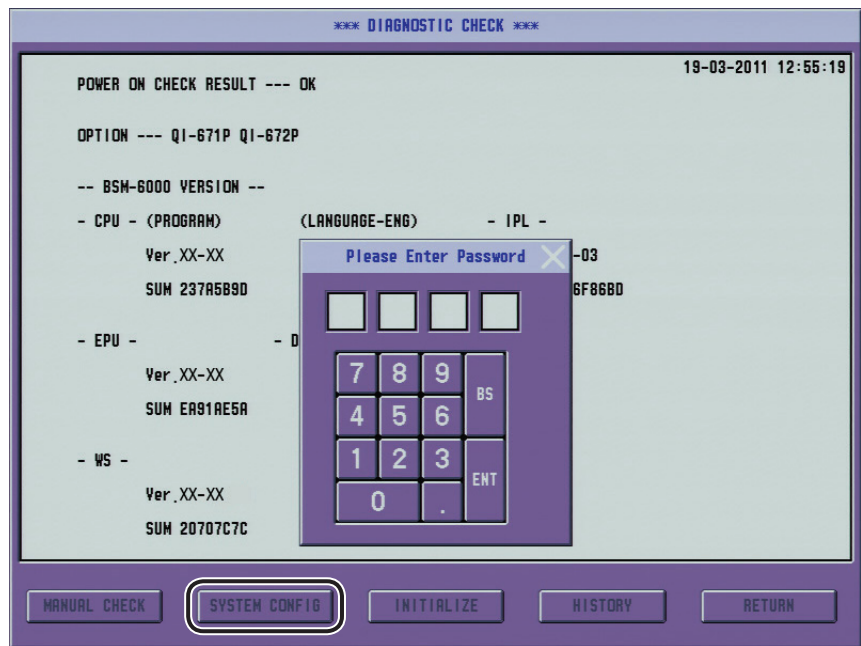

4. Enter the password with the number keys and touch the ENT key. The SYSTEM CONFIGURATION screen appears.

The default password is "1234".

5. Touch the desired tab to display the desired window.

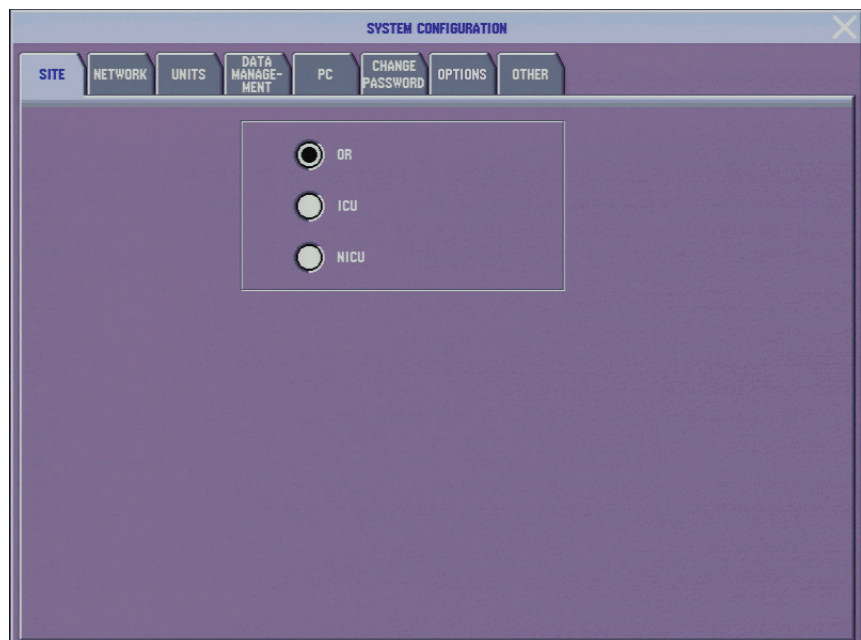

6. Change any necessary settings.

Closing the SYSTEM CONFIGURATION Screen

1. Touch the close button (☒) on the SYSTEM CONFIGURATION screen to return to the DIAGNOSTIC CHECK screen.
2. Touch the RETURN key. The home screen appears.



SITE Window

Select the site according to the operating environment. The default settings, including alarm upper and lower limit settings, differ according to site.

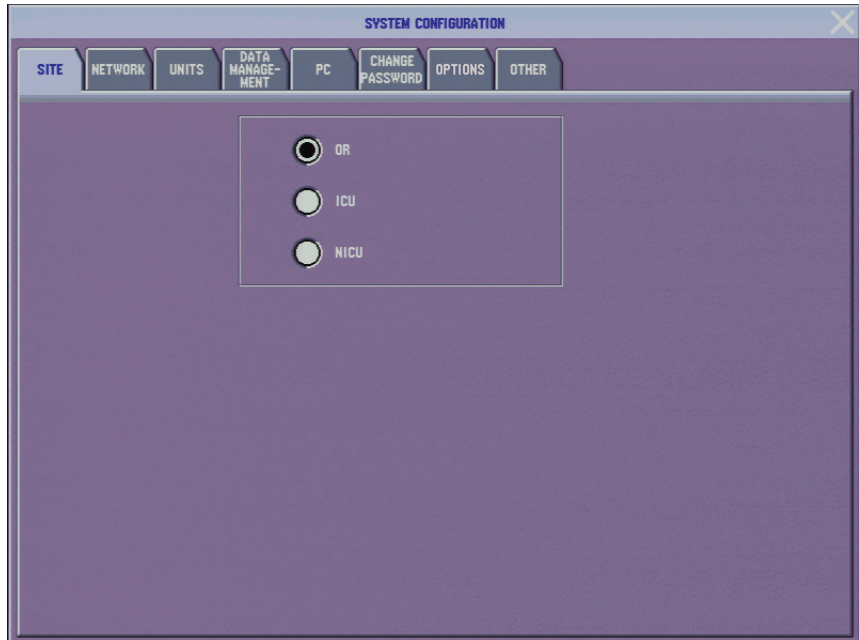

OR: Sleep mode is not available. SIM mode for NIBP is available.

ICU: Sleep mode is available. SIM mode for NIBP is not available.

NICU: Sleep mode is available. SIM mode for NIBP is not available.

On BSM-6000A series bedside monitor, 12 lead analysis can be set to on or off.

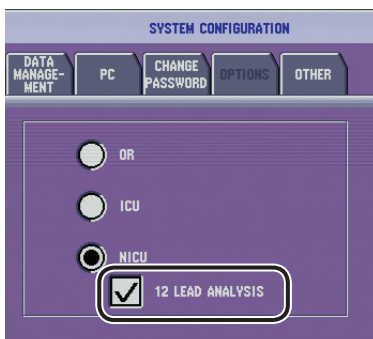

The sleep mode is only available when the ZS-900P* transmitter is connected or the bedside monitor is connected to the central monitor network.

* The ZS-900P transmitter is not available for the BSM-6000A series.

2. CHANGING SYSTEM CONFIGURATION SCREEN SETTINGS

To change the site, select the new site. The “SITE SETTING WILL BE CHANGED. OK?” message appears. Touch the YES key to change the site.

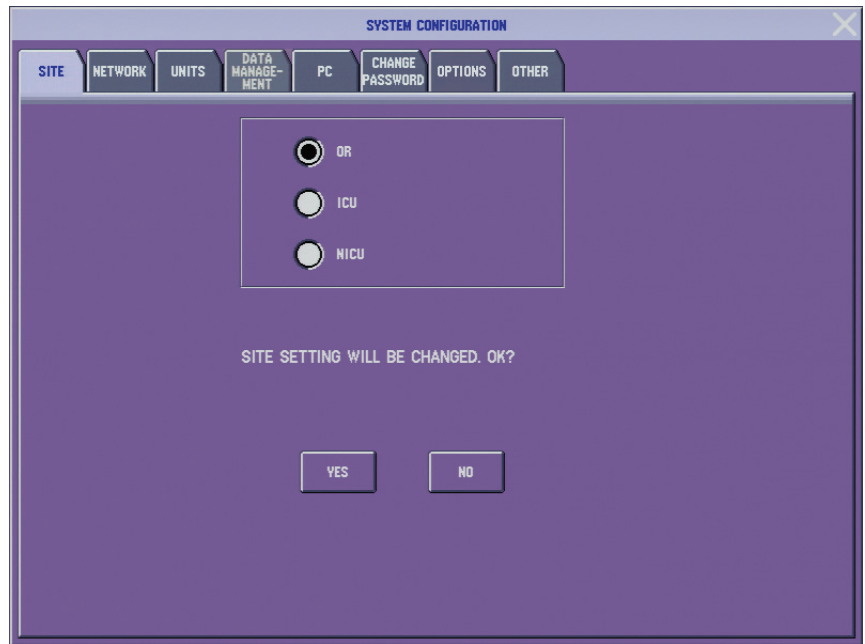

When the site is changed, the settings change to the factory default settings according to the new site. The factory default settings of the SYSTEM CONFIGURATION screen and SYSTEM SETUP window are listed in the “Factory Default Settings” in Section 4 of this manual. Other default settings are listed in the Operator’s Manual.

NETWORK Window

Set the network settings when the bedside monitor is connected to a central monitor network. HL7 page is only available on BSM-6000K series bedside monitor.

CAUTION

The network must be managed by the network administrator. Make sure that each monitor in the network has a different IP address. Otherwise, data communication cannot be performed properly. When adding a monitor to an already operating network, set the IP address on the monitor before connecting the monitor to the network.

CAUTION

When the monitor is connected to a central monitor network, set the Bed Name (Bed ID) and Group Name on the monitor. Otherwise, the default settings are used for the bed name and group name and the bed may be incorrectly identified on the central monitor.

IP ADDRESS/PROTOCOL Page

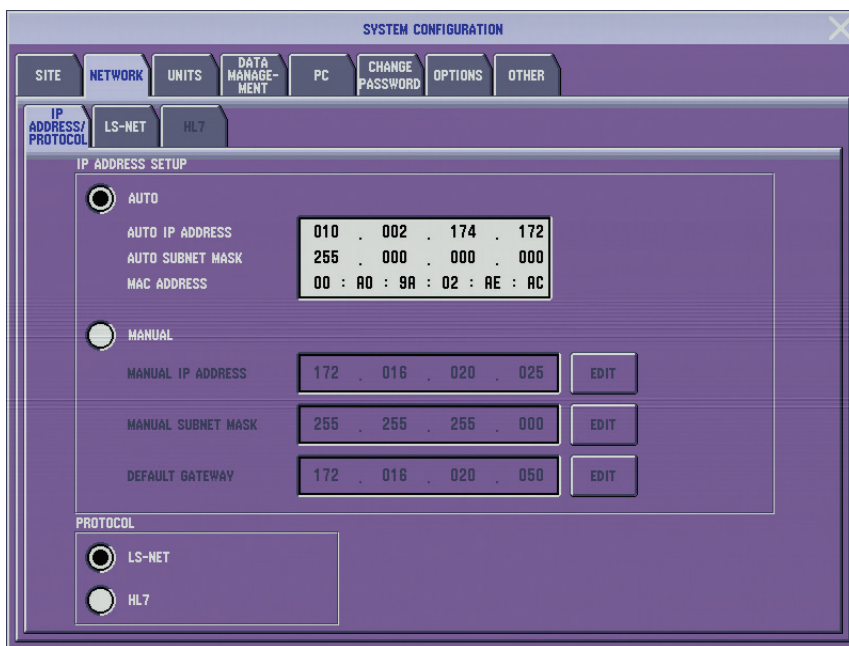

IP ADDRESS SETUP: AUTO, MANUAL

When set to AUTO, the IP address and subnet mask are set automatically.

When set to MANUAL, touch the EDIT key to set the IP address, subnet mask and default gateway.

PROTOCOL: LS-NET, HL7

This setting is only available on BSM-6000K series.

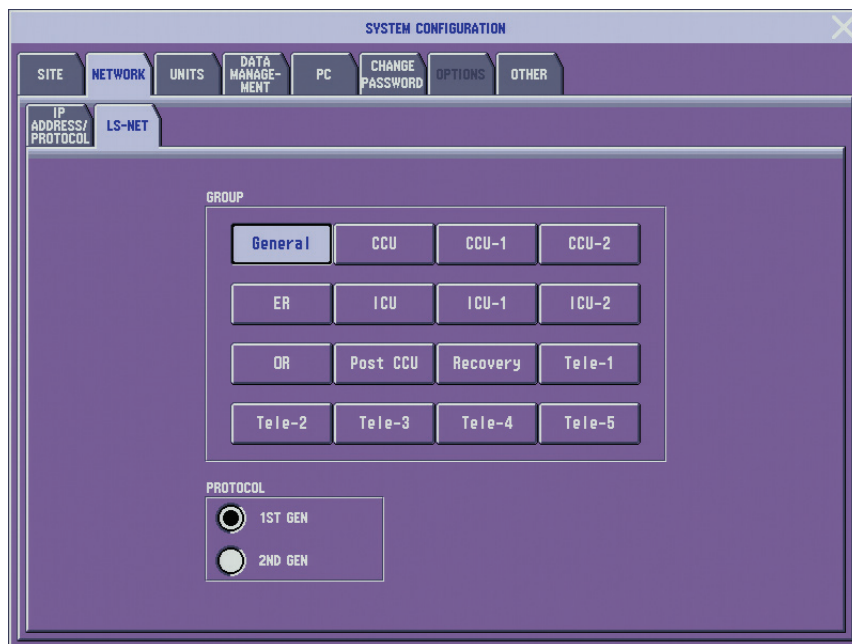

GROUP

Assign a group name for the bedside monitor. When the monitor has acquired the information of the network to which it is connected, the group names assigned by the central monitor appear. Select the group name from this list for the bedside monitor. For details, refer to the central monitor operator's manual.

PROTOCOL

This setting is not available on BSM-6000K series bedside monitors.

Select 1ST GEN when there are bedside monitors or central monitors which do not have the 2ND GEN setting. Select 2ND GEN when you need AF detection.

NOTE

- When <PROTOCOL> is changed to 2ND GEN and the bedside monitor is connected via 1ST GEN central monitor network, the "Lost communication with instruments in the network" message appears on the bedside monitor and the bedside monitor cannot be monitored on the central monitor.
- 2ND GEN can only be used with the following combination of instruments.
 - CNS-6201 central monitor Ver. 03-40 or later
 - CSM-1901 bedside monitor Ver. 01-21 or later
 - BSM-6000A series bedside monitor Ver. 07-01 or later
 - BSM-1700 series bedside monitor Ver. 01-15 or later
- <AVAILABLE ALARM TYPES> is fixed to ALL when <PROTOCOL> is set to 2ND GEN.

2. CHANGING SYSTEM CONFIGURATION SCREEN SETTINGS

HL7 Page

HL7 page is only available on BSM-6000K series. The entered items can be checked on the HL7 tab of the INFO page in the SYSTEM SETUP window.

SYSTEM CONFIGURATION															
SITE		NETWORK		UNITS		DATA MANAGEMENT		PC		CHANGE PASSWORD		OPTIONS		OTHER	
IP ADDRESS/ PROTOCOL		LS-NET		HL7											
ORU				ORF											
<input checked="" type="checkbox"/>	USE ORU			<input checked="" type="checkbox"/>	USE ORF										
	ORU PORT No.	7998			ORF PORT No.	9004									
	ORU SAMPLING	1 min		ADT											
QRY				<input checked="" type="checkbox"/>				USE ADT							
<input checked="" type="checkbox"/>	USE QRY			ADT MONITORING PORT No.				9005							
	HIS SERVER IP ADDRESS	000.000.000.000		ADT PATIENT INFO PORT No.				9006							
	HIS SERVER PORT No.	7997		PATIENT LIST PORT No.				9007							
MSH SEGMENT															
	HL7 VERSION	2.4		CHARACTER SET				ASCII							
	SENDING APPLICATION	NIHON KOHDEN		RECEIVING APPLICATION				CLIENT APP							
	SENDING FACILITY	NIHON KOHDEN		RECEIVING FACILITY				CLIENT FACILITY							

ORU

USE ORU: On, Off

Select whether to output the ORU (current numeric) data.

ORU PORT No.: 1024 to 65535

Select the port number to use for ORU data output.

ORU SAMPLING: 1 min, 5 min, 10 min, 30 min, 60 min

Select the interval to output the ORU data.

ORF

USE ORF: On, Off

Select whether to output the ORF (old numeric) data.

ORF PORT No.: 1024 to 65535

Select the port number for ORF data output.

QRY

USE QRY: On, Off

Select whether to request patient information.

HIS SERVER IP ADDRESS

Select the IP address of the HIS server.

HIS SERVER PORT No.: 1024 to 65535

Select the port number that is used by HIS server for receiving patient information.

ADT

USE ADT: On, Off

Select whether to output the admit and discharge, patient information update and presence check information.

ADT MONITORING PORT No.: 1024 to 65535

Select the port number for admitting or discharging a patient from an external system.

ADT PATIENT INFO PORT No.: 1024 to 65535

Select the port number for entering the patient information including patient ID from an external system.

PATIENT LIST PORT No.: 1024 to 65535

Select the port number for requesting the admit condition of a patient from an external system.

MSH SEGMENT

HL7 VERSION

Shows the HL7 version.

CHARACTER SET

Shows the character code type.

SENDING APPLICATION: Up to 32 characters

Select the names in the HL7 telegram.

SENDING FACILITY: Up to 32 characters

Select the names in the HL7 telegram.

RECEIVING APPLICATION: Up to 32 characters

Select the names in the HL7 telegram.

RECEIVING FACILITY: Up to 32 characters

Select the names in the HL7 telegram.

UNITS Window

Select the unit for each parameter.

The screenshot shows the 'SYSTEM CONFIGURATION' window with the 'UNITS' tab selected. The window is divided into two columns of settings. Each setting consists of a radio button and a text label. The parameters and their available units are as follows:

Parameter	Available Units
HEIGHT	cm, inch
WEIGHT	kg, pound
ST	mV, mm
TEMPERATURE	°C, °F
HEMOGLOBIN	g/dL, mmol/L
BLOOD PRESSURE	mmHg, kPa
CO ₂	mmHg, kPa
RESPIRATION	cmH ₂ O, hPa
tcPO ₂ /PCO ₂	mmHg, kPa

WARNING

ST, CO₂, RESPIRATION, tcPO₂/tcPCO₂ and HEMOGLOBIN settings only affect the individual bedside monitor, not on all monitors connected to the network. The unit settings must be the same on all bedside monitors and central monitors in the network. Otherwise, the different measurement values and alarms will be displayed on different monitors depending on the unit settings on each monitor.

NOTE

The CO₂, respiration and tcPO₂/tcPCO₂ unit settings are not available on the BSM-6000A series.

DATA MANAGEMENT Window

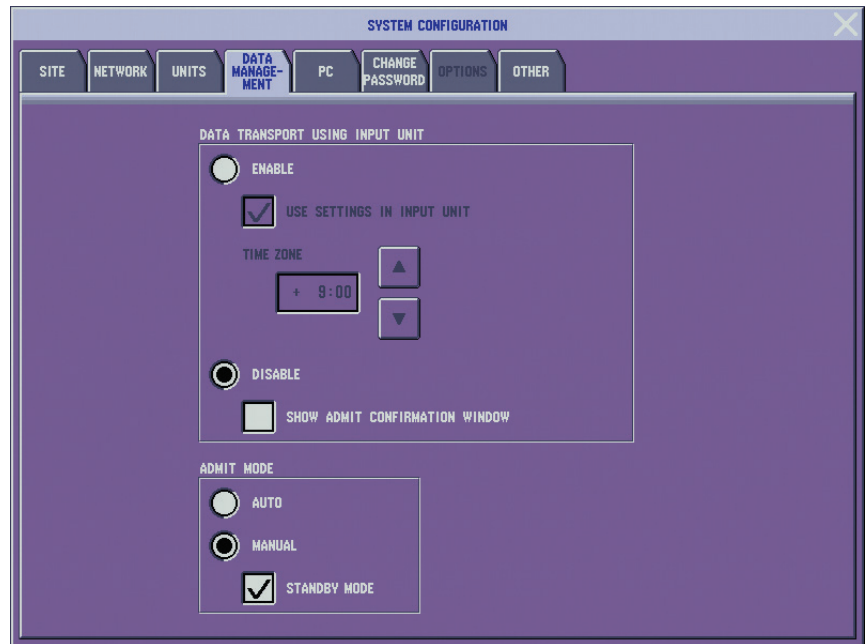

DATA TRANSPORT USING INPUT UNIT: ENABLE, DISABLE

Select whether to enable the transport function. When the transport function is enabled, the patient information and review data can be sent to another bed by disconnecting the input unit from one monitor and connecting it into another monitor.

NOTE

To use the transport function, set the <DATA TRANSPORT USING INPUT UNIT> setting on both the original monitor and the destination monitor to ENABLE.

ENABLE: Enable the transport function of the monitor.

DISABLE: Disable the transport function of the monitor.

USE SETTINGS IN INPUT UNIT: On, Off

This setting becomes available when “ENABLE” is selected for “DATA TRANSPORT USING INPUT UNIT”.

On: Patient information, pacing detection On/Off, QRS detection type, arrhythmia analysis On/Off, vital sign upper/lower alarm limits settings, arrhythmia alarms settings, arrhythmia recall settings, parameters to be saved for full disclosure and ECG lead settings of TRACE 1 and TRACE 2 are saved and applied to the destination monitor.

Off: Patient information, pacing detection On/Off and QRS detection type are saved and applied to the destination monitor.

2. CHANGING SYSTEM CONFIGURATION SCREEN SETTINGS

NOTE

On BSM-6000A series, if <CRISIS VITAL ALARM MANAGEMENT> on the SYSTEM CONFIGURATION screen is turned on and “ALARM PRIORITY” of the following parameters is set to CRISIS on the destination monitor, the alarm settings on the destination monitor have priority and the source monitor settings are not applied to the destination monitor.

Parameters:

HR/PR UPPER, HR/PR LOWER, RR UPPER, RR LOWER, APNEA, SpO₂ UPPER, SpO₂ LOWER, SpO₂-2 UPPER, SpO₂-2 LOWER, CO₂ (E) UPPER, CO₂ (E) LOWER, arrhythmia alarms

TIME ZONE: 0 to ±12:00

This setting becomes available when “ENABLE” is selected for <DATA TRANSPORT USING INPUT UNIT>.

CAUTION

When installing the monitor, change the time zone setting to the same setting as the other bedside monitors and central monitors. If the time zone setting is not the same, the data which was in the input unit before transport is deleted when using the transport function with the input unit.

Set the time zone in respect to GMT (Greenwich Mean Time). The time difference can be selected in 30 minute steps.

This setting must be the same on all monitors in the same network. Otherwise data communication problems may occur.

You can also change the time zone setting on the OTHER window of the SYSTEM CONFIGURATION screen.

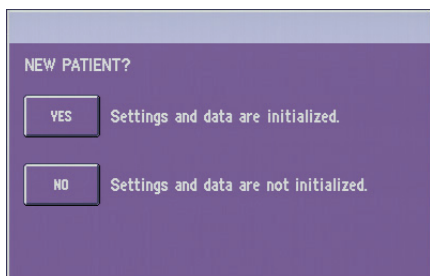

SHOW ADMIT CONFIRMATION WINDOW: On, Off

This setting is available when <DATA TRANSPORT USING INPUT UNIT> is set to DISABLE.

On: The ADMIT CONFIRMATION window appears when the monitor is turned on. On the ADMIT CONFIRMATION window, you can select whether or not to monitor a new patient.

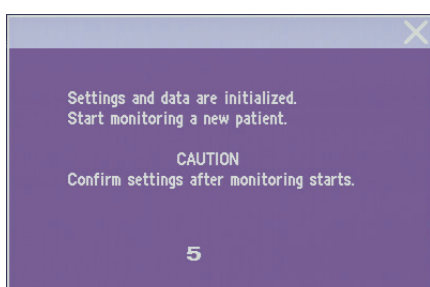

When <ADMIT MODE> is set to MANUAL and the patient was discharged before turning the power off, the “DISCHARGED” message and the STANDBY window appear instead of the ADMIT CONFIRMATION window.

Off: The ADMIT CONFIRMATION window does not appear when the monitor is turned on.

2. CHANGING SYSTEM CONFIGURATION SCREEN SETTINGS

When the monitor is turned on after the monitor has been off for 30 minutes or more, the message appears indicating that the patient data at the power off is deleted and the settings are initialized.

When the monitor is turned on within 30 minutes after the power was turned off, the patient data and settings at the power off are kept and monitoring resumes when the same conditions as the alarm function resuming after suspending alarms are met.

ADMIT MODE: AUTO, MANUAL

Select whether to automatically start monitoring after a discharge procedure or when the monitor is turned on.

AUTO: Starts monitoring when the same conditions as the alarm function resuming after suspending alarms are met. The patient is automatically admitted, but the previous patient data is not deleted and the settings are not initialized.

When <SHOW ADMIT CONFIRMATION WINDOW> is set to on, you can select whether or not to monitor a new patient.

MANUAL: When a patient is discharged, the “DISCHARGED” message and the STANDBY window appear. The patient must be admitted to start monitoring.

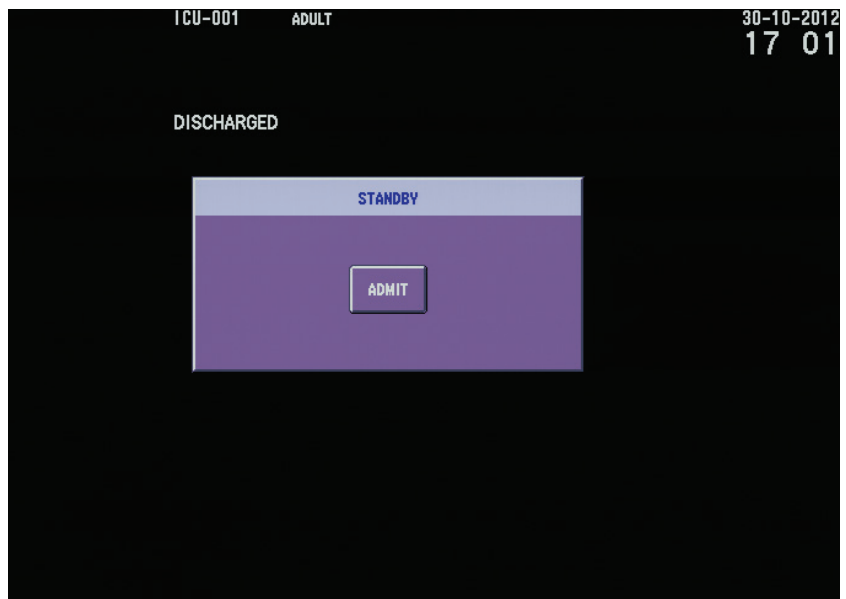

When a patient was not discharged at the monitor power off and <SHOW ADMIT CONFIRMATION WINDOW> is set to off, if the monitor is turned on more than 30 minutes after turning the power off, the message appears indicating that the patient data is deleted at the power off and the settings are initialized. If the monitor is turned on within 30 minutes after turning the power off, the patient data and settings at the power off are kept and monitoring continues when the same conditions as the alarm function resuming after suspending alarms are met.

2. CHANGING SYSTEM CONFIGURATION SCREEN SETTINGS

STANDBY MODE: On, Off

Select whether a patient can be admitted on the STANDBY window when <ADMIT MODE> is set to MANUAL.

On: A MONITOR key is displayed on the STANDBY window. Pressing the MONITOR key automatically admits the patient and displays the home screen.

Off: An ADMIT key is displayed on the STANDBY window. Touch the ADMIT key to admit a patient on the ADMIT window. The home screen appears after the patient is admitted.

PC Window

2

Change settings according to the PC connected to the bedside monitor.

The screenshot displays the 'SYSTEM CONFIGURATION' window with the 'PC' tab selected. The window contains four sections of settings, each with radio button options:

- BAUD RATE:** 9600 (selected), 19200, 38400
- PARITY:** NONE (selected), EVEN, ODD
- WORD LENGTH:** 7 bits, 8 bits (selected)
- STOP BIT:** 1 (selected), 2

CHANGE PASSWORD Window

Set the 4-digit password required for displaying the SYSTEM SETUP window.

1. Enter the current password in the <OLD PASSWORD> boxes using the number keys on the screen. The default password is “1234”.

The screenshot shows the 'SYSTEM CONFIGURATION' window with the 'CHANGE PASSWORD' tab selected. The interface includes a menu bar with options: SITE, NETWORK, UNITS, DATA MANAGEMENT, PC, CHANGE PASSWORD, OPTIONS, and OTHER. Below the menu, there are two rows of four input boxes each, labeled 'OLD PASSWORD' and 'NEW PASSWORD'. Below these fields is a numeric keypad with keys for digits 0-9, a decimal point, and function keys 'BS' and 'ENT'. The text 'PLEASE ENTER OLD PASSWORD' is displayed above the keypad.

2. Touch the ENT key. The “PLEASE ENTER NEW PASSWORD” message appears.
3. Enter the new password in the <NEW PASSWORD> boxes using the number keys on the screen.

The screenshot shows the 'SYSTEM CONFIGURATION' window with the 'CHANGE PASSWORD' tab selected. The 'OLD PASSWORD' and 'NEW PASSWORD' fields now each contain four asterisks. The text 'PASSWORD CHANGED.' is displayed above the numeric keypad, which remains visible at the bottom of the screen.

4. Touch the ENT key to register the new password.

OPTIONS Window

When the optional QP-033P Hemodynamics Review Program or QP-034P esCCO program is installed, you need to obtain an unlock code from Nihon Kohden to use the program. Tell us the registration code on the OPTIONS window and we will tell you the unlock code. Use the registration form at the end of the manual.

NOTE

- The QP-033P Hemodynamics Review Program and QP-034P esCCO program are not available for BSM-6000A series.
 - When using the BSM-1700 series bedside monitor as an input unit for the BSM-6000K series bedside monitor,
 - also authorize the esCCO software for the BSM-1700 series. Refer to the QP-172P esCCO program Operator's Manual.
 - set <DATA TRANSPORT USING INPUT UNIT> on the DATA MANAGEMENT window of the SYSTEM CONFIGURATION screen to ENABLE.
1. Display the esCCO or HEMO GRAPH page of the OPTIONS window.
 - esCCO page: for registering QP-034P
 - HEMO GRAPH page: for registering QP-033P

The screenshot shows the 'SYSTEM CONFIGURATION' window with the 'OPTIONS' tab selected. Under 'OPTIONS', the 'esCCO' sub-tab is active. The 'REGISTRATION CODE' field contains '77-024-566'. Below it is a 'PASSWORD' field consisting of 12 empty boxes. A numeric keypad is visible at the bottom, with letters A-F above the numbers 0-9, and 'BS' and 'ENT' keys.

2. Note the registration code in the REGISTRATION CODE box on the window.
3. Fill in the registration form and fax or send it to your Nihon Kohden representative.
4. After you receive the unlock code, display the esCCO or HEMO GRAPH page of the OPTIONS window on the SYSTEM CONFIGURATION screen and enter the code number in the PASSWORD box using the number and alphabet keys on the screen. When the ENT key is touched, the lock is unlocked.

OTHER Window

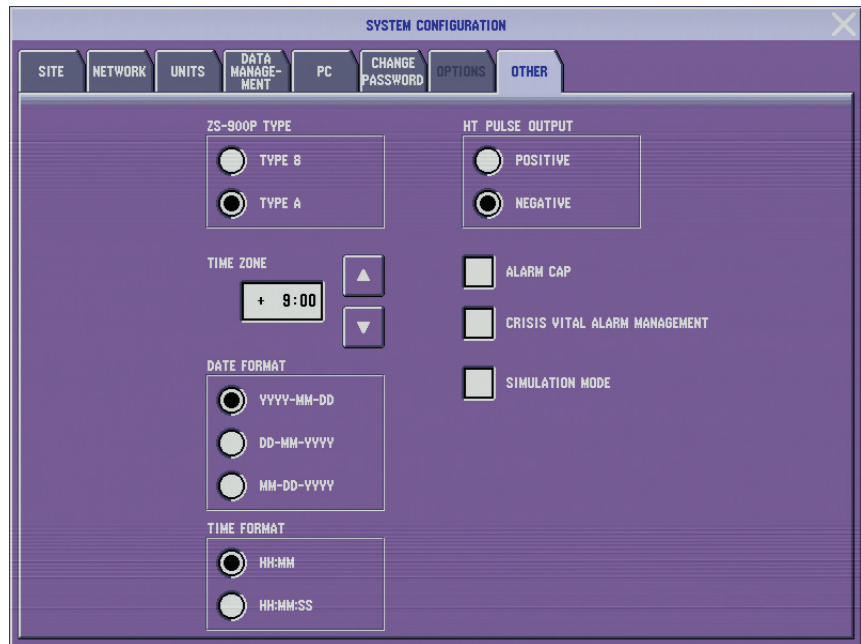

<ALARM CAP> and <CRISIS VITAL ALARM MANAGEMENT> are displayed only on BSM-6000A series.

ZS-900P TYPE: TYPE 8, TYPE A

Select the parameter group for transmitting data by the ZS-900P transmitter. CO₂ data cannot be received by a monitor on which CO₂ is not available.

TYPE 8: ECG, SpO₂, NIBP, IBP connected to MULTI socket 1 or 2, temperature connected to the TEMP sockets and respiration (thermistor) connected to MULTI socket 1 or 2

TYPE A: ECG, SpO₂, NIBP, IBP connected to MULTI socket 1 or 2, temperature connected to the TEMP sockets and CO₂ or respiration (thermistor) connected to MULTI socket 1 or 2

The ZS-900P transmitter is not available for the BSM-6000A series.

HT PULSE OUTPUT: POSITIVE, NEGATIVE

Select the polarity of the HT pulse signal which is output from the ECG/BP OUT socket.

TIME ZONE: 0 to ±12:00

Set the time zone in respect to GMT (Greenwich Mean Time). The time difference can be selected in 30 minute steps.

This setting must be the same on all monitors in the same network. Otherwise data communication problems may occur.

ALARM CAP

When this item is checked, the “ALARM CAP” setting becomes available. Refer to “ALARM CAP Page” in Section 3 for details.

This is only available on BSM-6000A series.

CRISIS VITAL ALARM MANAGEMENT

Select whether to manage the high priority vital alarms.

This is only available on BSM-6000A series bedside monitor.

NOTE

If this item is checked and “ALARM PRIORITY” of the following parameters is set to CRISIS, the alarm setting for that parameter is set to the alarm master setting and the alarm master cannot be set to OFF.

Parameters:

HR/PR UPPER, HR/PR LOWER, RR UPPER, RR LOWER, APNEA, SpO₂ UPPER, SpO₂ LOWER, SpO₂-2 UPPER, SpO₂-2 LOWER, CO₂ (E) UPPER, CO₂ (E) LOWER

SIMULATION MODE

When this item is checked, it enters SIMULATION MODE and when it returns to the home screen, simulated waveforms and numeric value appear on the screen. These can be used for demonstration of the monitor.

When the power is turned off after SIMULATION MODE is checked, SIMULATION MODE is turned off.

For normal monitoring, uncheck this item.

DATE FORMAT: YYYY-MM-DD, DD-MM-YYYY, MM-DD-YYYY

Select the date format.

TIME FORMAT: HH:MM, HH:MM:SS

Select the time format.

Initializing the Monitor

Use the following procedure to initialize the monitor. Initializing the monitor sets all settings to the factory default settings for ICU mode. The factory default settings of the SYSTEM CONFIGURATION screen and SYSTEM SETUP window are listed in the “Factory Default Settings” in Section 4 of this manual. Other default settings are listed in the Operator’s Manual.

CAUTION

All patient data and stored data are deleted and all settings return to the factory default settings.

1. If the monitor power is on, turn it off.
2. Press the [power] switch while pressing the [Silence Alarms] key on the front panel until the DIAGNOSTIC CHECK screen is displayed.
3. Touch the INITIALIZE key. The dialog box to enter the password appears.

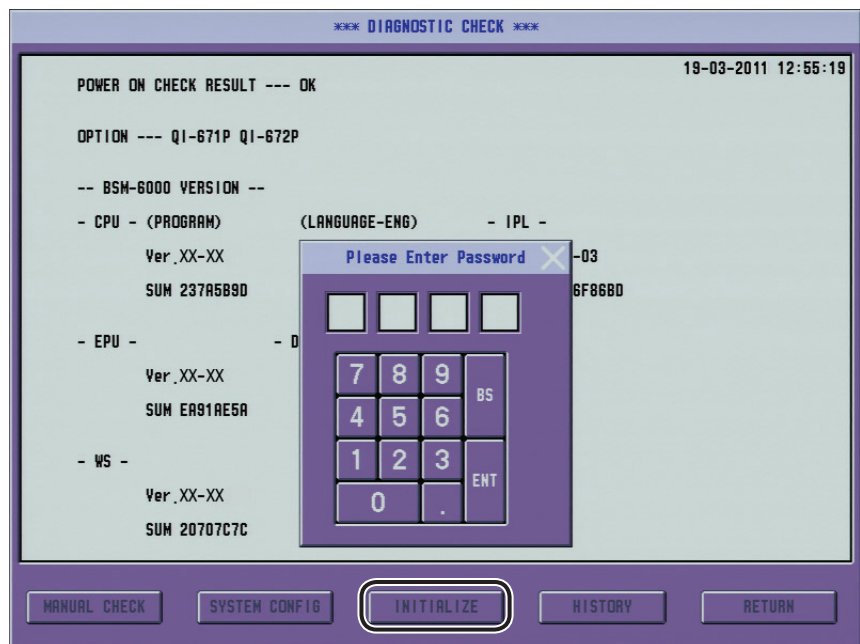
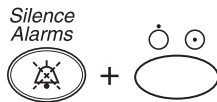

4. Enter the password with the number keys and touch the ENT key. The confirmation dialog box appears.

The default password is “1234”.

2. CHANGING SYSTEM CONFIGURATION SCREEN SETTINGS

5. Touch the YES key to initialize the monitor.

Touch the NO key to cancel initializing.

2

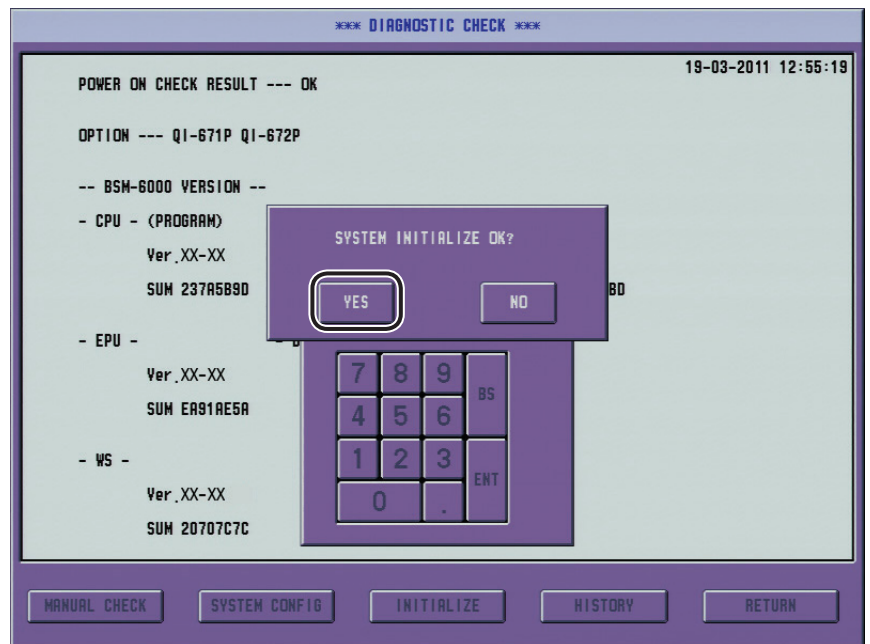

When initializing is finished, the “SYSTEM INITIALIZED” message appears.

6. Touch the RETURN key on the DIAGNOSTIC CHECK screen to display the home screen.

Section 3 *Changing SYSTEM SETUP Window Settings*

Overview.....	3.3
Setting Items on the SYSTEM SETUP Window	3.3
Displaying the SYSTEM SETUP Window	3.9
Closing the SYSTEM SETUP Window	3.10
The INFO Page of the INFO Window	3.11
The CONFIGURATION Page of the INFO Window	3.11
The MAINTENANCE Page of the INFO Window.....	3.12
BATTERY Tab.....	3.12
LOAD/SAVE SETTINGS Tab	3.12
SYSTEM Window	3.15
DISPLAY Page	3.15
LAYOUT Page	3.17
VOLUME Page	3.20
INTERBED Page	3.21
BED ID Window	3.22
PARAMETERS Window.....	3.23
ECG Page	3.23
NIBP Page.....	3.25
NIBP MODE Page	3.27
STAT Tab	3.27
SIM Tab	3.28
INTERVAL Tab	3.29
VENOUS PUNCTURE Tab	3.29
INITIAL CUFF PRESS Tab.....	3.30
CO ₂ Page.....	3.30
GAS Page	3.31
MAINTENANCE Tab	3.31
SETTINGS Tab.....	3.31
INFO Tab	3.33
FLOW/Paw Page	3.33
CAL Tab.....	3.33
SETTINGS Tab.....	3.34
MAINTENANCE Tab	3.34
INFO Tab	3.35
EEG Page	3.35
OTHER PARAM Page	3.36
ALARM Window.....	3.38
SILENCE/SUSPEND Page	3.38
DISPLAY/SOUND Page	3.40
ALARM PRIORITY Page.....	3.42
ARRHYTH PRIORITY Page.....	3.48
TECHNICAL PRIORITY Page.....	3.49
SLEEP Page	3.50

NETWORK Page.....	3.51
ALARM CAP Page	3.52
LATCHING Page	3.53
COLOR Window	3.55
RECORD Window	3.57
RECORDER Page.....	3.57
PRINTER Page	3.59
Using Network Printer	3.60
MASTER Window	3.62
PATIENT TYPE Page.....	3.63
Renaming an Alarm Master	3.63
MAIN ALARMS, ECG ALARMS, PRESS ALARMS, TEMP ALARMS, GAS ALARMS, OTHER	
ALARMS Pages	3.64
ARRHYTH Page.....	3.65
RY-910P/MOUSE Window.....	3.67
KEYS Window	3.68

Overview

This section explains how to change settings on the SYSTEM SETUP window. The SYSTEM SETUP window can only be entered by an administrator who has the password to access these windows. Changing the settings on the SYSTEM SETUP window does not interrupt monitoring, but it is recommended to check and change them before monitoring a patient because these settings involve basic measurement conditions.

Setting Items on the SYSTEM SETUP Window

SYSTEM - DISPLAY page

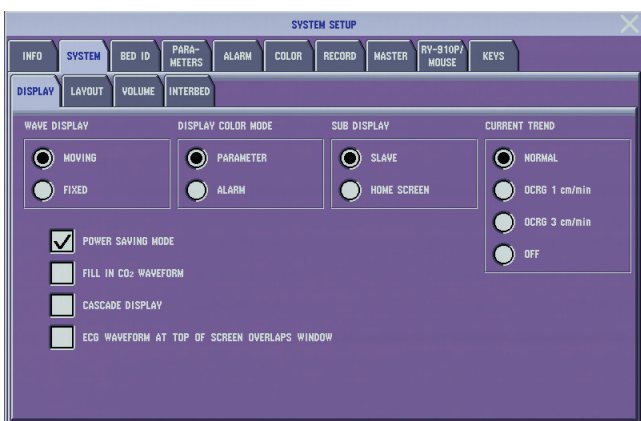

SYSTEM - LAYOUT page

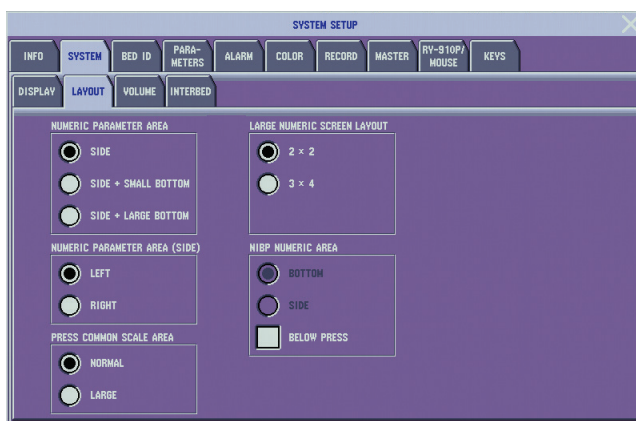

SYSTEM - VOLUME page

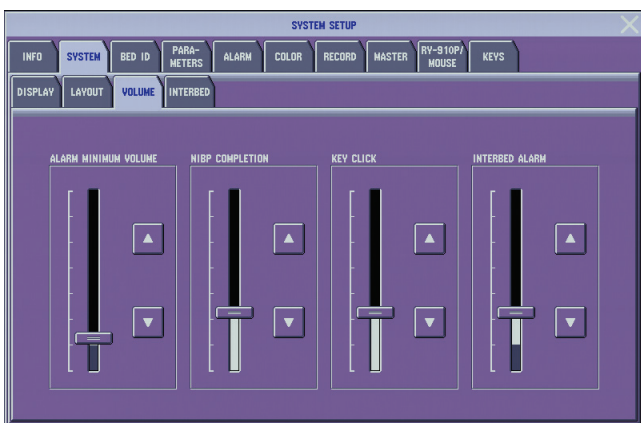

SYSTEM - INTERBED page



BED ID window



PARAMETERS - ECG page

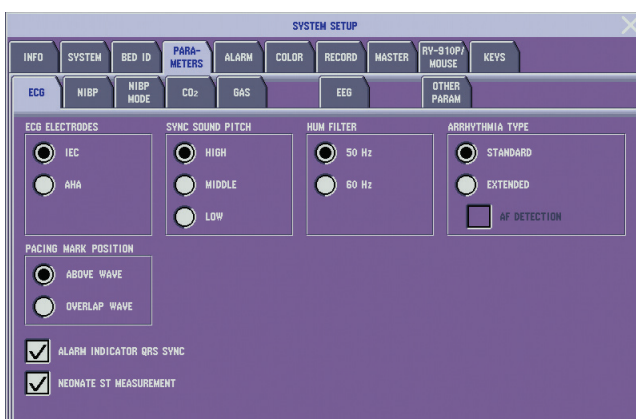

* AF detection is not available for BSM-6000K series.

3. CHANGING SYSTEM SETUP WINDOW SETTINGS

PARAMETERS - NIBP page

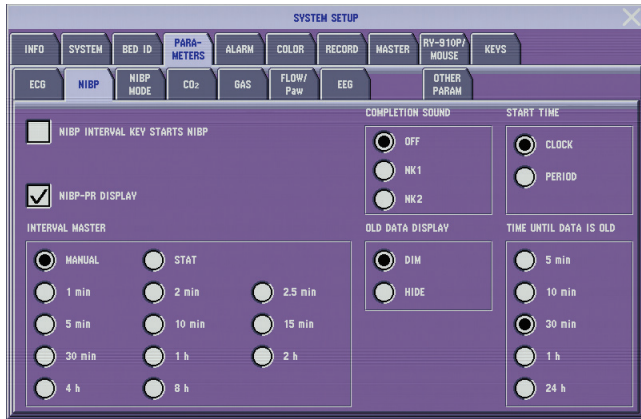

PARAMETERS - NIBP MODE - STAT tab

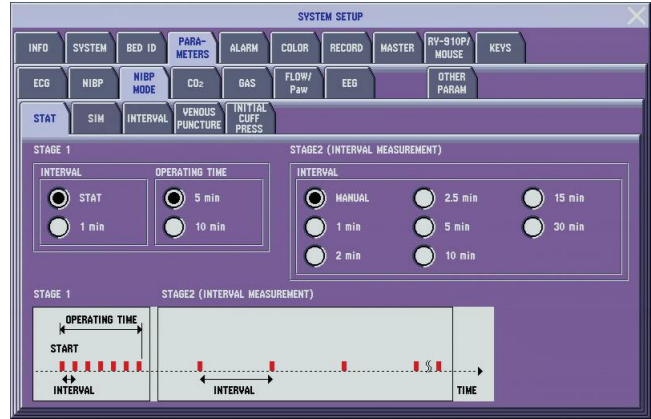

PARAMETERS - NIBP MODE - SIM tab (OR site only)

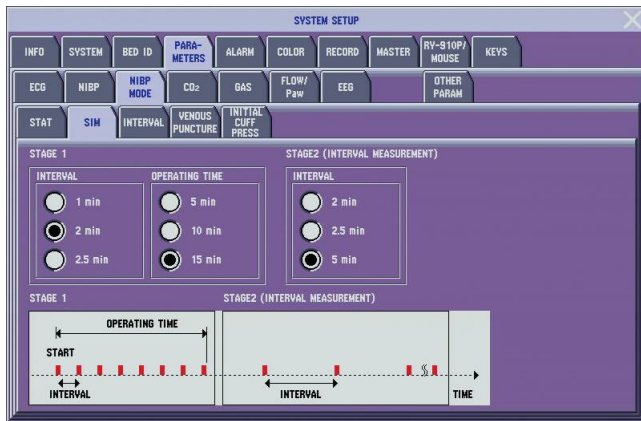

PARAMETERS - NIBP MODE - INTERVAL tab

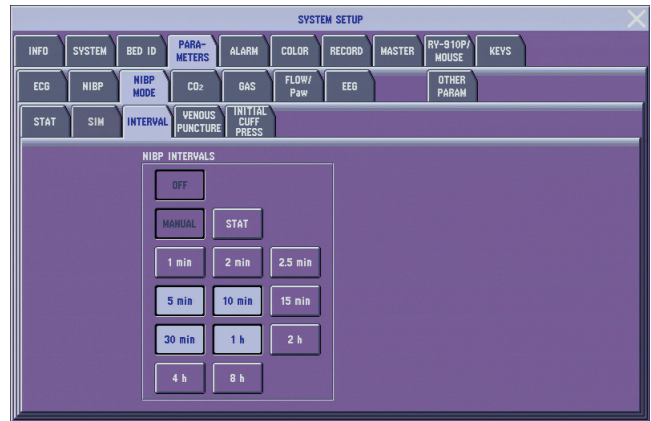

PARAMETERS - NIBP MODE - VENOUS PUNCTURE tab

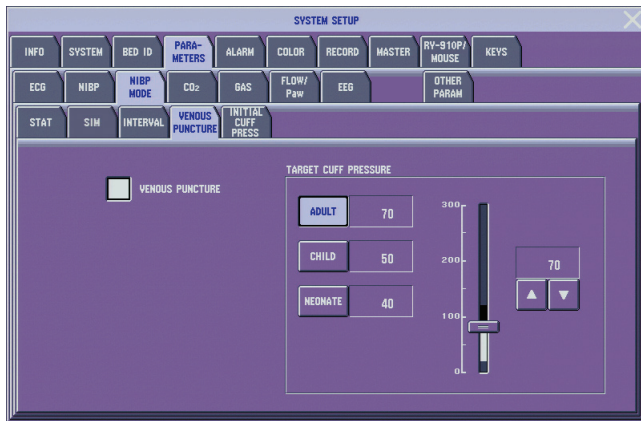

PARAMETERS - NIBP MODE - INITIAL CUFF PRESS tab

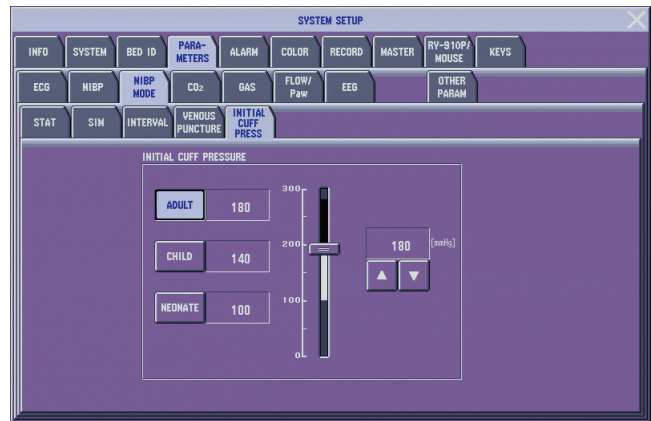

PARAMETERS - CO₂ page

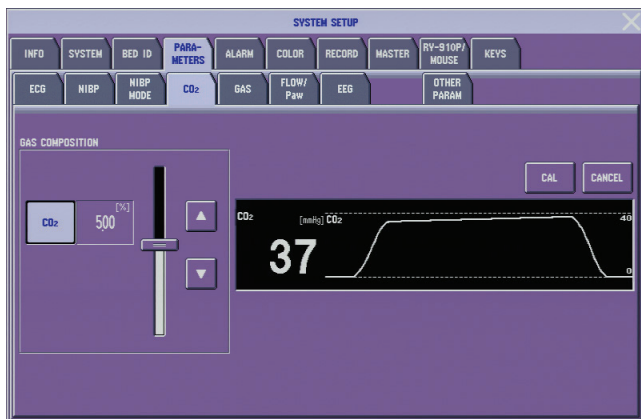

PARAMETERS - GAS - MAINTENANCE tab

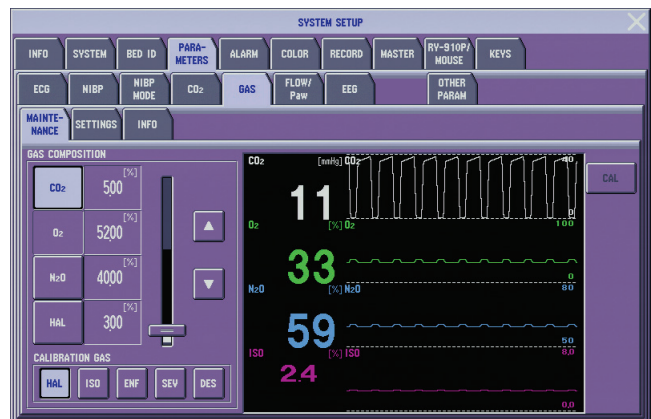

3. CHANGING SYSTEM SETUP WINDOW SETTINGS

PARAMETERS - GAS - SETTINGS tab

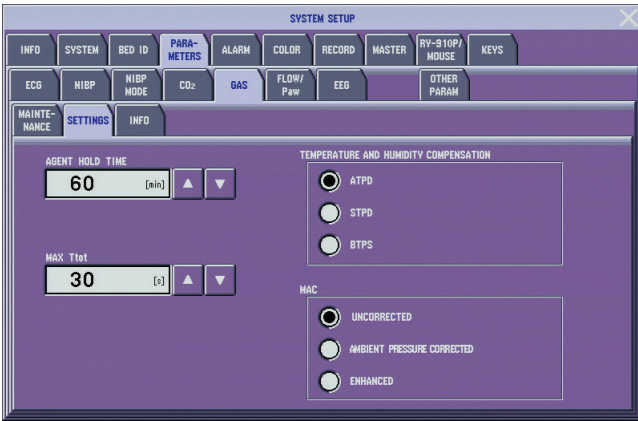

PARAMETERS - GAS - INFO tab



PARAMETERS - FLOW/Paw* - CAL tab

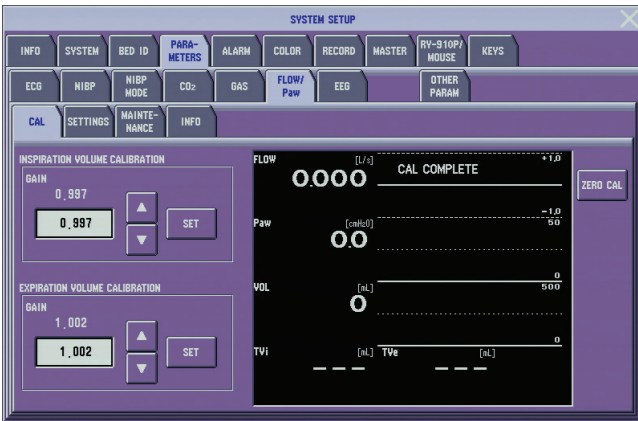

PARAMETERS - FLOW/Paw* - SETTINGS tab

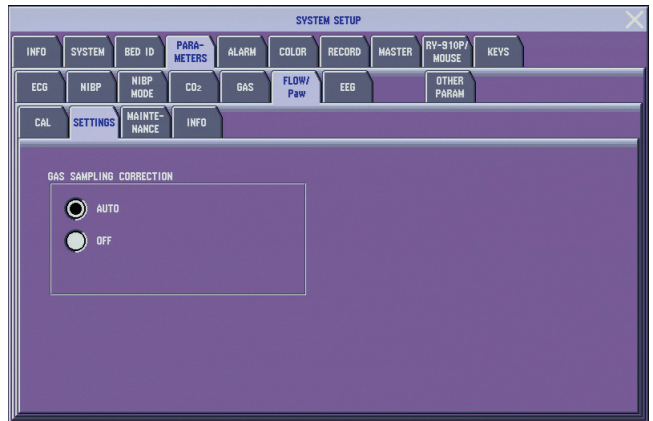

PARAMETERS - FLOW/Paw* - MAINTENANCE tab

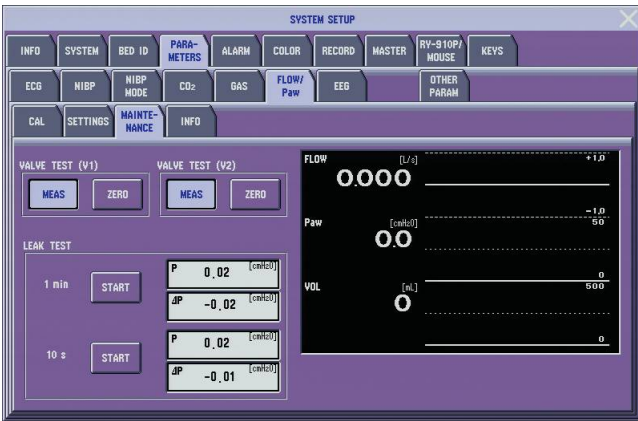

PARAMETERS - FLOW/Paw* - INFO tab



PARAMETERS - EEG page

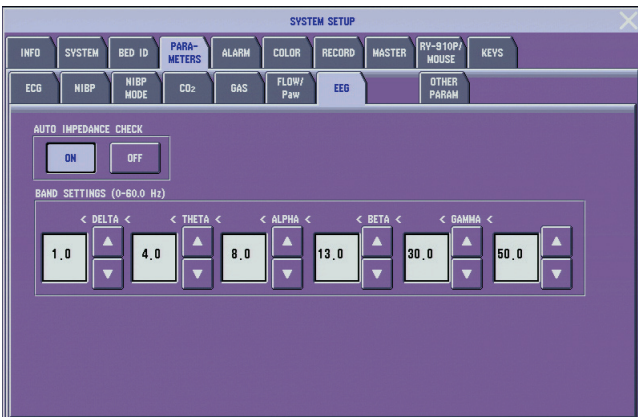

PARAMETERS - OTHER PARAM page

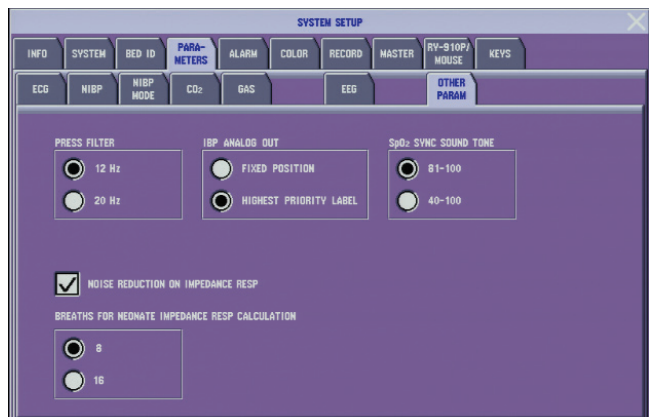

* The FLOW/Paw tab is not available for BSM-6000A series.

3. CHANGING SYSTEM SETUP WINDOW SETTINGS

ALARM - SILENCE/SUSPEND page

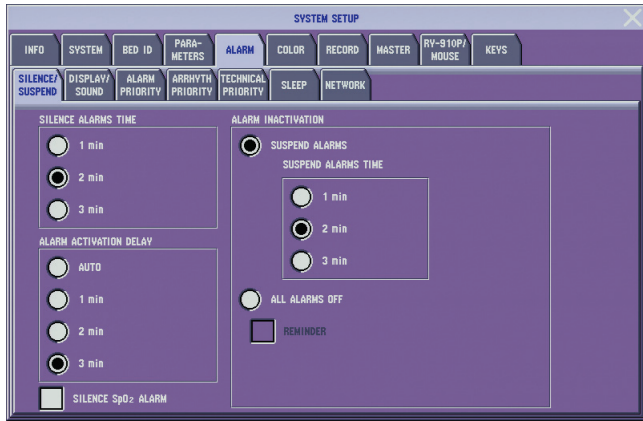

ALARM - DISPLAY/SOUND page

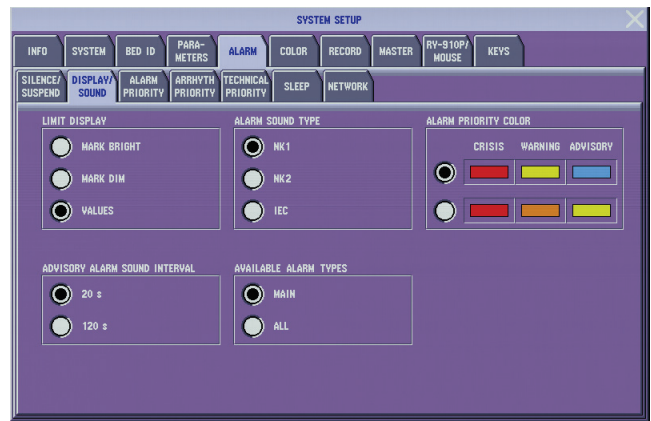

ALARM - ALARM PRIORITY page

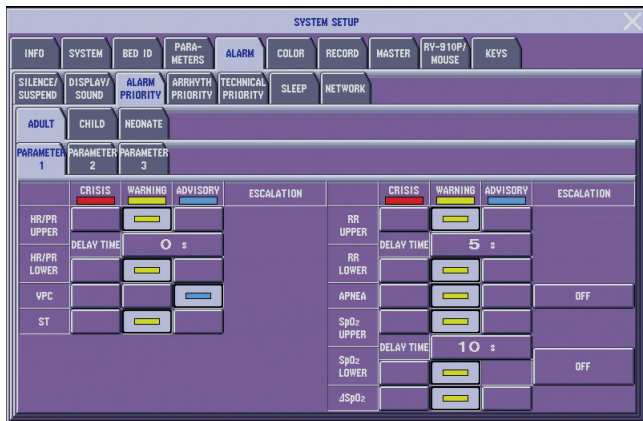

ALARM - ARRHYTHM PRIORITY page

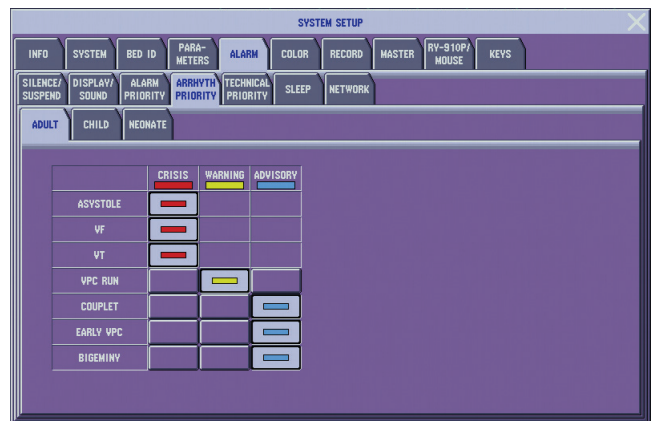

ALARM - TECHNICAL PRIORITY page



ALARM - SLEEP page

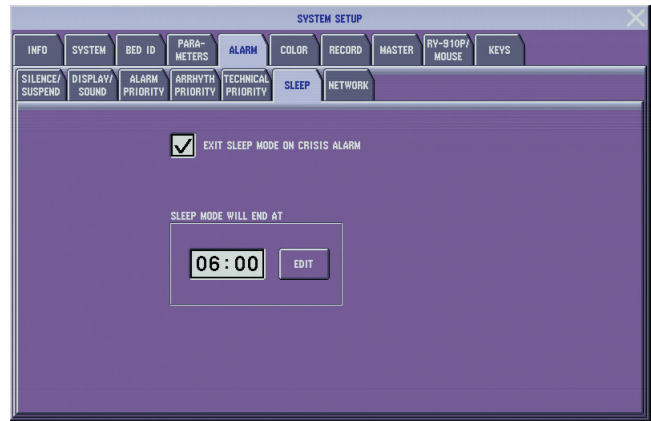

ALARM - NETWORK page

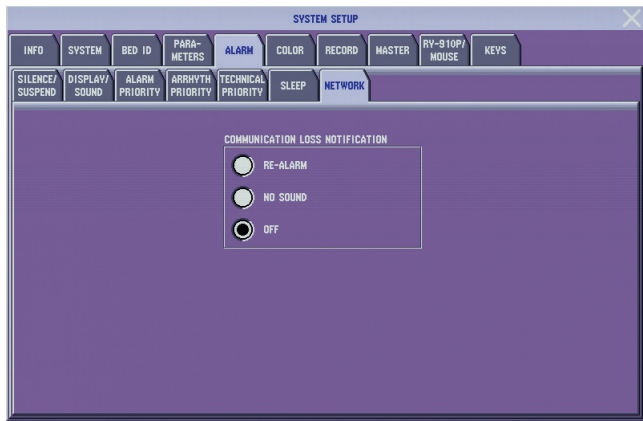

ALARM - ALARM CAP page*

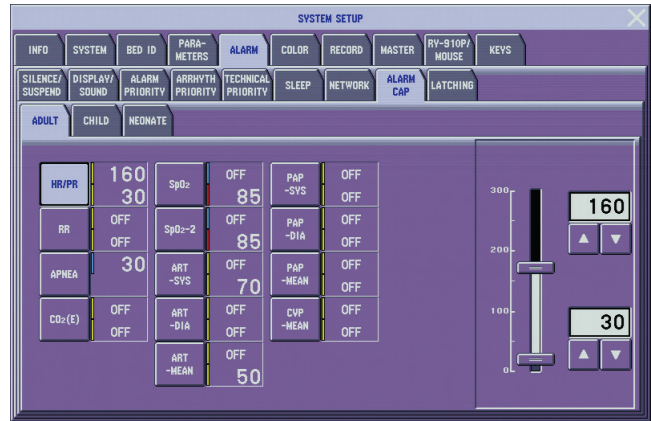

* ALARM CAP page is only available on BSM-6000A series and when <ALARM CAP> on the SYSTEM CONFIGURATION screen is turned on.

ALARM - LATCHING page*



COLOR window

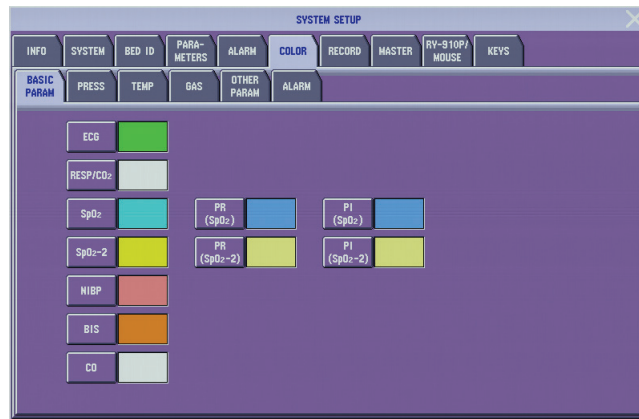

RECORD - RECORDER page



RECORD - PRINTER page

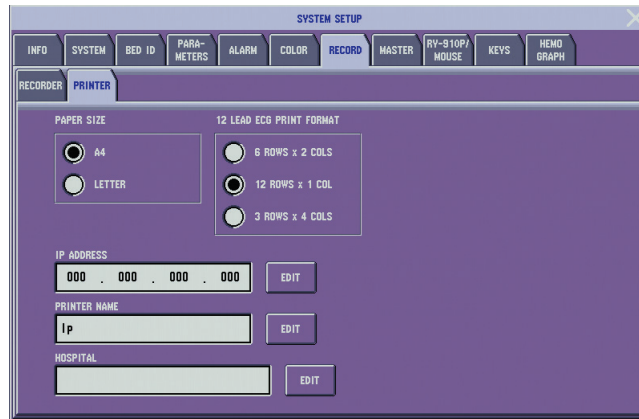

MASTER - PATIENT TYPE page

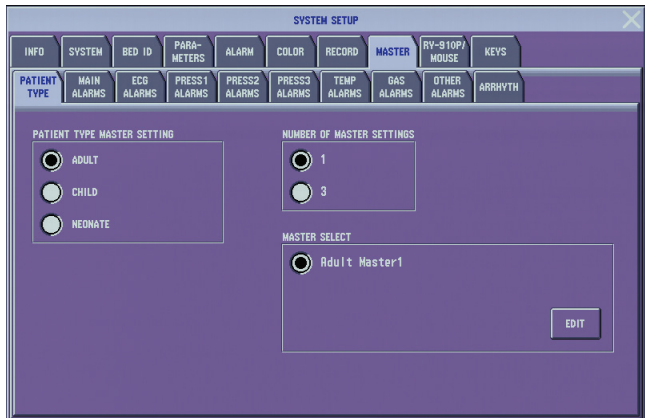

MASTER - MAIN ALARMS page

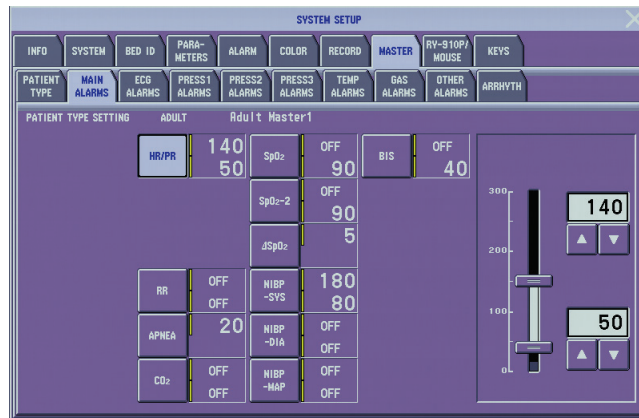

MASTER - ARRHYTHM page

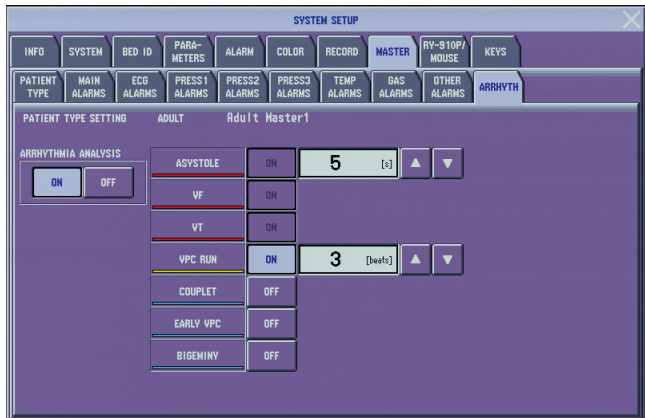

RY-910P/MOUSE window

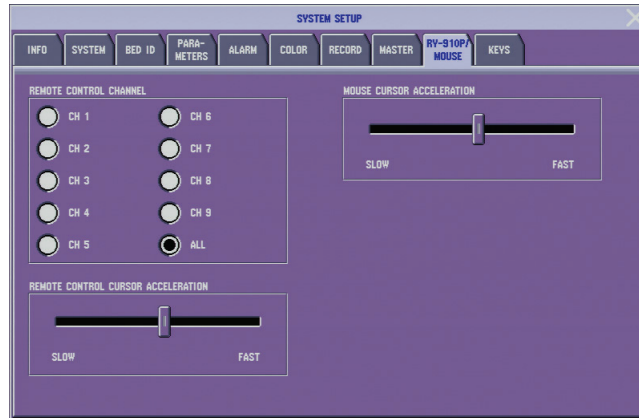

* LATCHING page is only available on BSM-6000A series.

3. CHANGING SYSTEM SETUP WINDOW SETTINGS

KEYS window

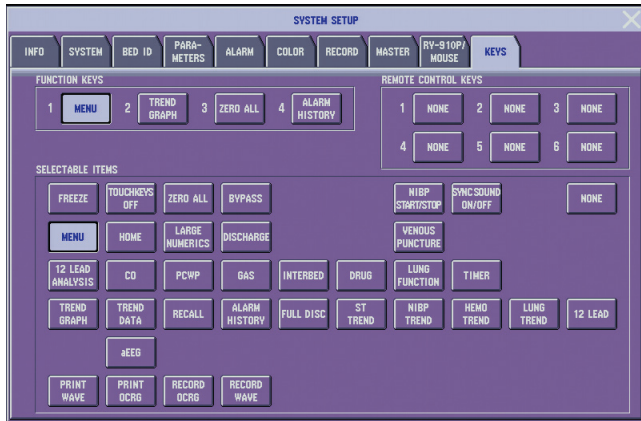

Displaying the SYSTEM SETUP Window

- Menu*  1. Press the [Menu] key on the front panel to display the MENU window.
2. Touch the SYSTEM key on the MENU window.

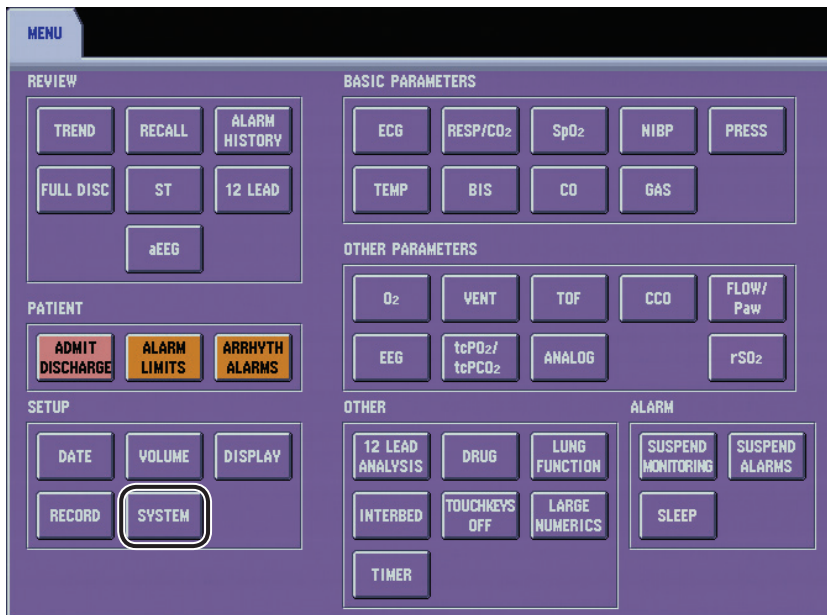

3. Enter the password with the number keys and touch the ENT key. The SYSTEM SETUP window appears. (The default password is “1234”.)

The password is set on the CHANGE PASSWORD window of the SYSTEM CONFIGURATION screen. Refer to Section 2.

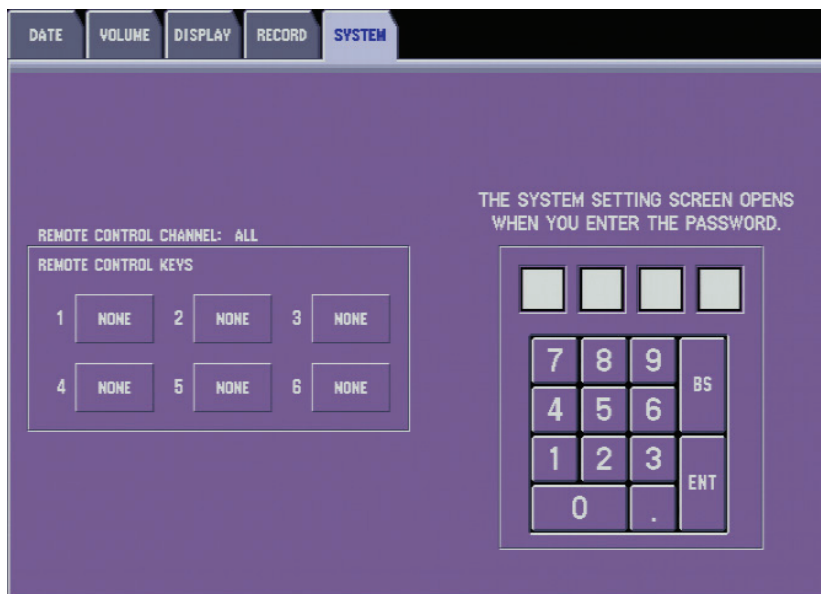

3. CHANGING SYSTEM SETUP WINDOW SETTINGS

4. Touch the desired setting tab to display the desired window.

Setting tabs

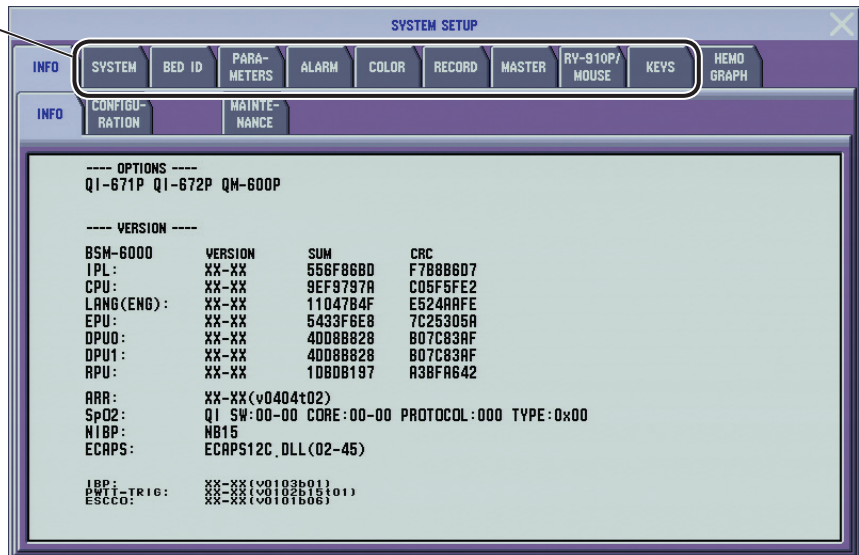

5. Change any necessary settings.

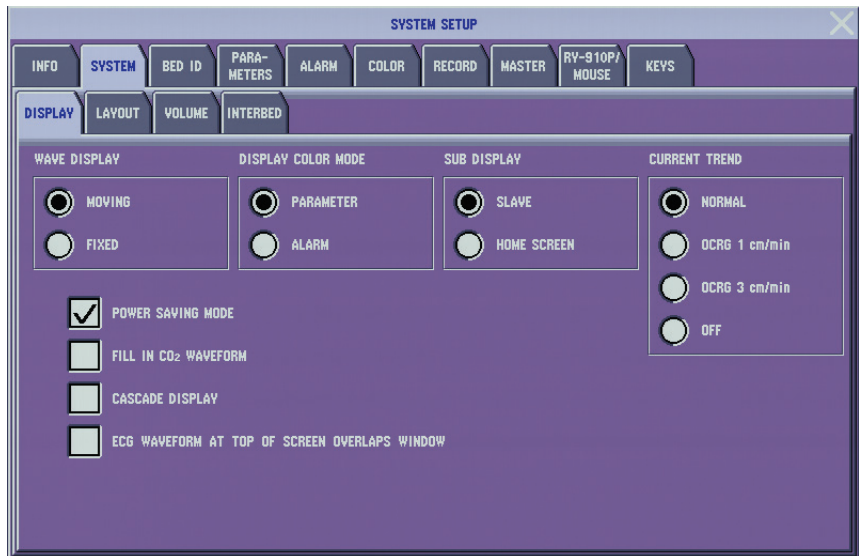

Closing the SYSTEM SETUP Window



Touch the close button (X) or press the [Home] key. The home screen appears.

The INFO Page of the INFO Window

The INFO page shows the software version of the monitor. The page also lists the options installed in the monitor.

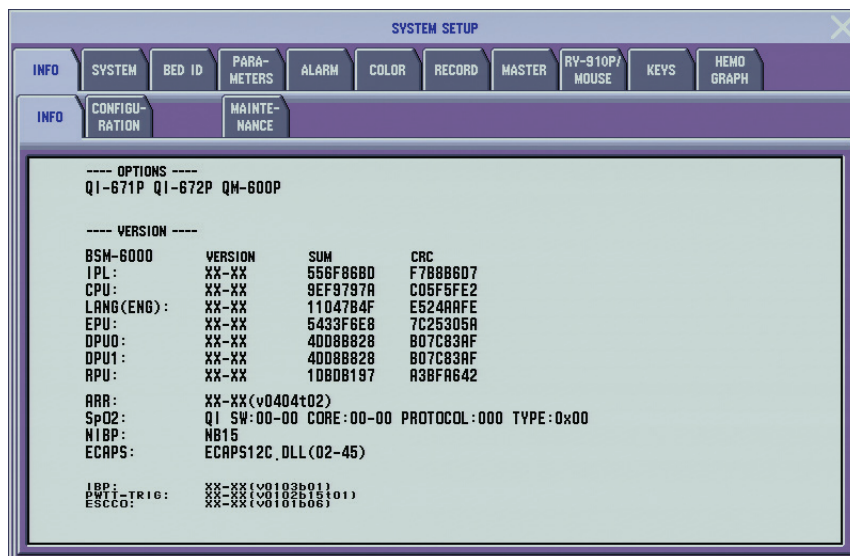

The CONFIGURATION Page of the INFO Window

The CONFIGURATION page shows the settings on the SYSTEM CONFIGURATION screen of the DIAGNOSTIC CHECK screen. This lets you check the contents of the settings without having to restart the monitor to display the SYSTEM CONFIGURATION screen.

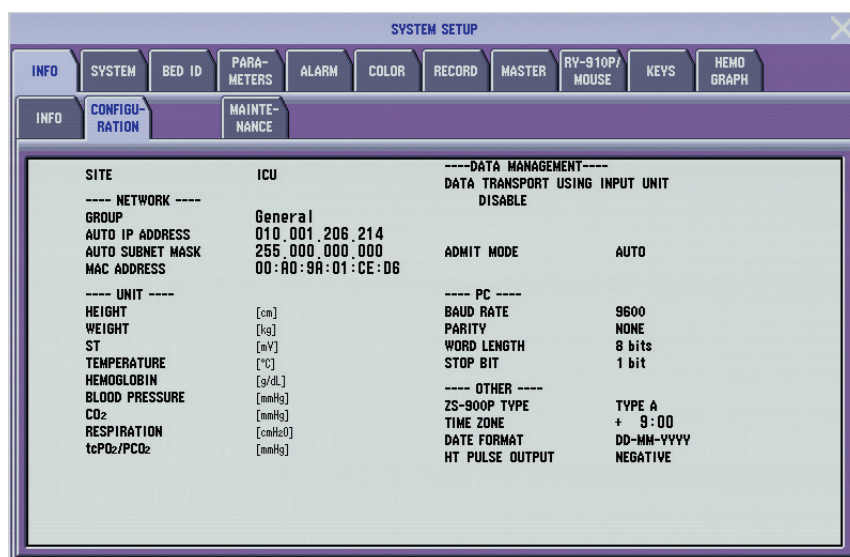

NOTE

The settings on the SITE and CHANGE PASSWORD windows are not displayed.

3. CHANGING SYSTEM SETUP WINDOW SETTINGS

The MAINTENANCE Page of the INFO Window

The MAINTENANCE page has two tabs.

BATTERY Tab

The BATTERY tab shows the status of the batteries installed in the monitor.

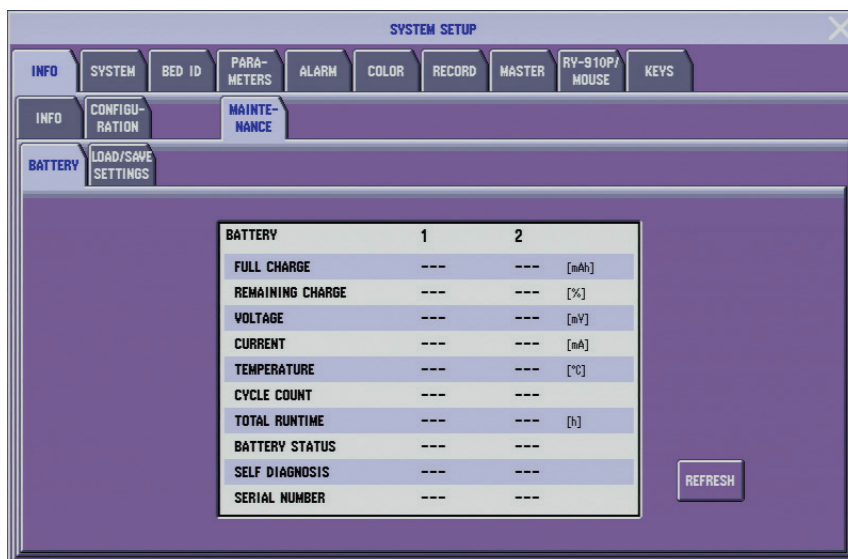

LOAD/SAVE SETTINGS Tab

On the LOAD/SAVE SETTINGS tab, you can save settings on the monitor as a file to the SD card and copy the settings to a different monitor.

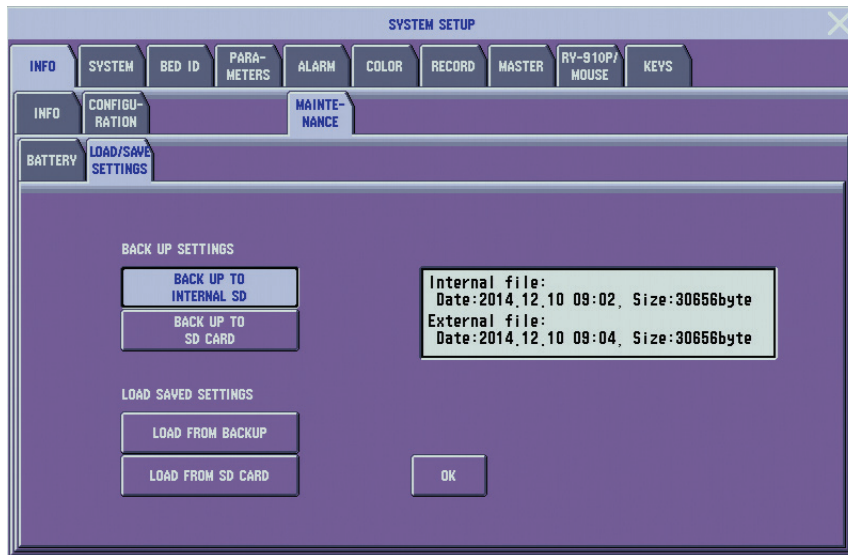

Backing Up Settings

NOTE

For BSM-6000A series, the settings return to the settings saved in the internal SD card when:

- A patient is admitted or discharged.
- <SHOW ADMIT CONFIRMATION WINDOW> is turned off in the SYSTEM CONFIGURATION screen and 30 minutes elapse after monitor power off.

Check that the current settings is appropriate before saving the settings. For the returned settings, consult your Nihon Kohden representative.

1. Touch BACK UP TO INTERNAL SD in <BACK UP SETTINGS>.
2. Touch OK to back up the settings.

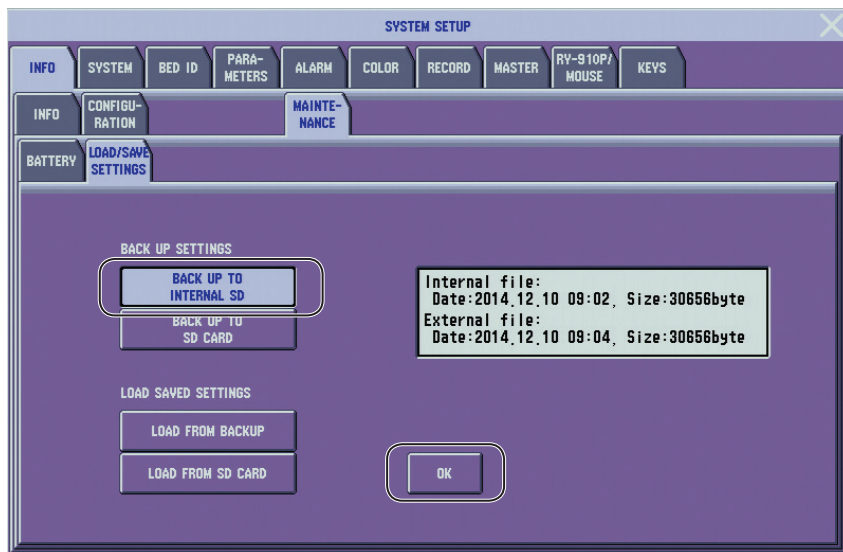

3. Close the SYSTEM SETUP window by touching .



Loading Settings

1. Touch LOAD FROM BACKUP in <LOAD SAVED SETTINGS>.
2. Touch OK to execute loading the settings.

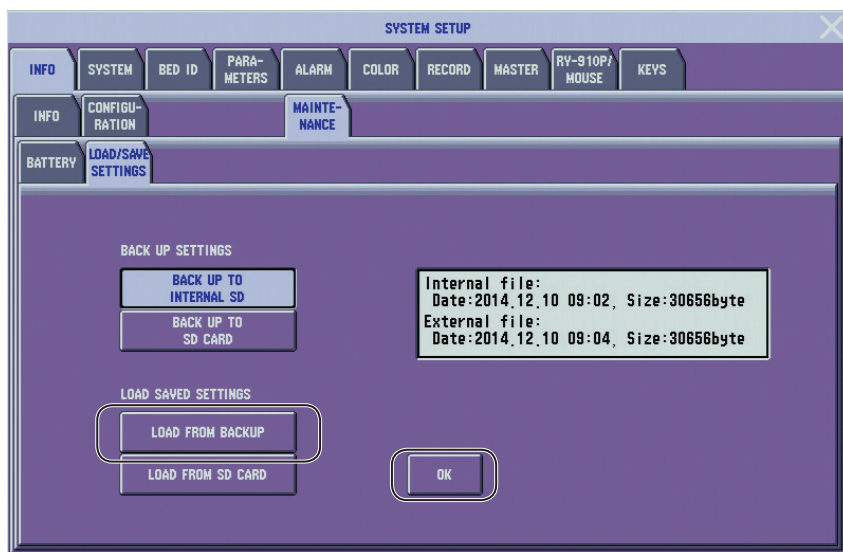

3. CHANGING SYSTEM SETUP WINDOW SETTINGS

3. Close the SYSTEM SETUP window by touching .

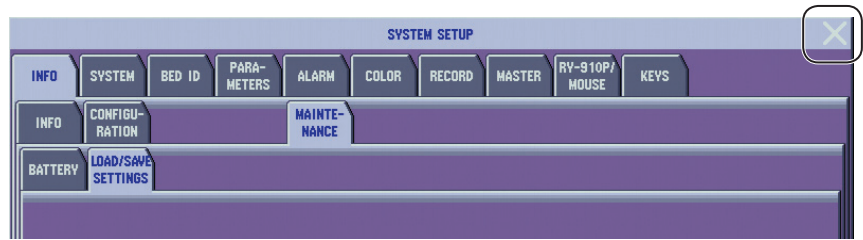

4. Turn off the power to the monitor and then turn it on to restart the monitor.

SYSTEM Window

The SYSTEM window has four pages.

3

DISPLAY Page

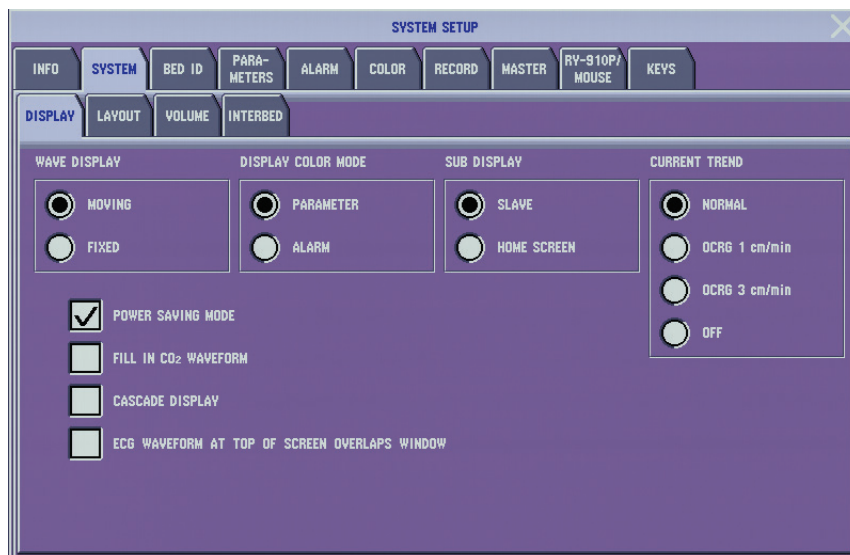

WAVE DISPLAY: MOVING, FIXED

Select waveform sweep mode on the home screen.

MOVING: Waveform sweeps from the right.

FIXED: Waveform does not sweep; it is refreshed from the left.

DISPLAY COLOR MODE: PARAMETER, ALARM

There are two color display modes.

PARAMETER: A different color can be set for each parameter. When an alarm occurs, the alarmed parameter data is highlighted.

ALARM: The same color selected at <ALARM MODE COLOR> of the COLOR window is set for all parameters. When an alarm occurs, the alarmed parameter color changes according to the color set at <ALARM PRIORITY COLOR> of the ALARM window.

SUB DISPLAY: SLAVE, HOME SCREEN

Select the screen to be displayed on the sub display.

SLAVE: Same screen as the bedside monitor is displayed on the sub display.

HOME SCREEN: The home screen is always displayed.

When FIXED is selected for <WAVE DISPLAY> and HOME SCREEN is selected for <SUB DISPLAY>, trendgraph and OCRG cannot be displayed.

3. CHANGING SYSTEM SETUP WINDOW SETTINGS

CURRENT TREND: NORMAL, OCRG 1 cm/min, OCRG 3 cm/min, OFF

Select the trendgraph type displayed on the home screen.

NORMAL: Trendgraph

OCRG 1 cm/min: OCRG display with the horizontal scale 1 cm/min

OCRG 3 cm/min: OCRG display with the horizontal scale 3 cm/min

OFF: No trendgraph/OCRG display on the home screen

POWER SAVING MODE: On, Off

When operating the monitor on battery power, the brightness of the screen can be adjusted to save battery power.

On: Dim, longer battery operation time

Off: Normal screen brightness, shorter battery operation time

FILL IN CO₂ WAVEFORM: On, Off

When set to On, the CO₂ waveform is filled in.

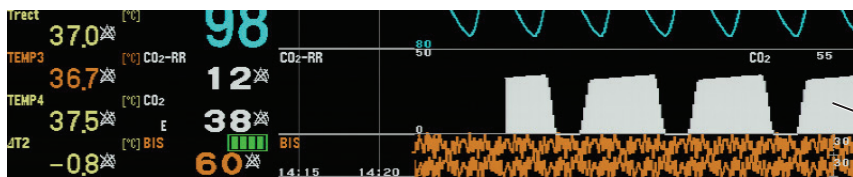

CASCADE DISPLAY: On, Off

Select whether or not to cascade the ECG waveform on the home screen. This setting is only available when the NUMERIC PARAMETER AREA setting on the LAYOUT page is set to LEFT SIDE.

When On is selected for <CASCADE DISPLAY> and HOME SCREEN is selected for <SUB DISPLAY>, <CURRENT TREND> is automatically set to OFF.

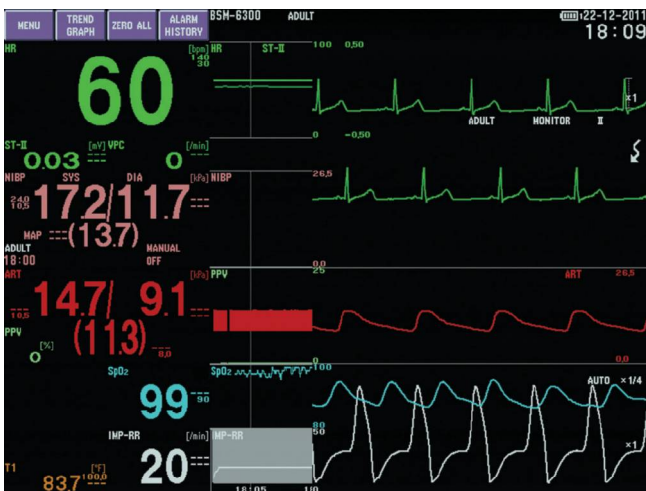

On



Off

ECG WAVEFORM AT TOP OF SCREEN OVERLAPS WINDOW: On, Off

Select whether or not to overlap the ECG waveform on the window.



On



Off

LAYOUT Page

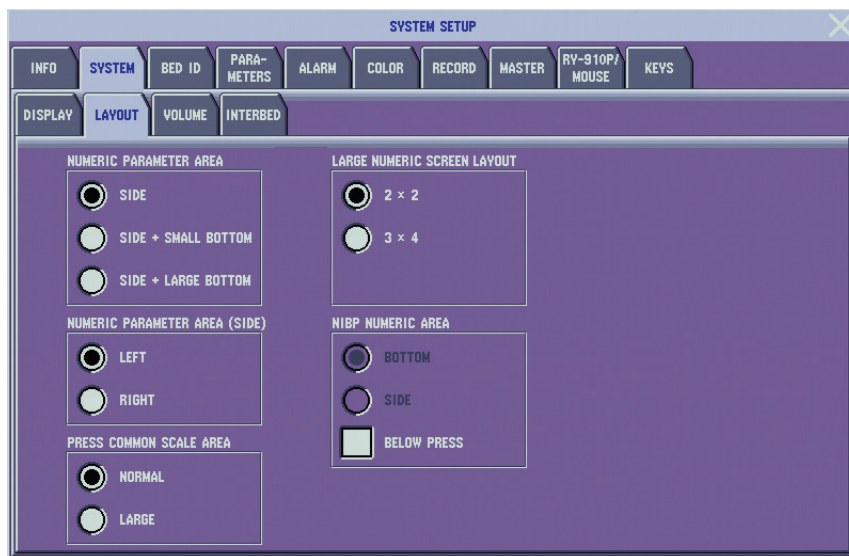

NUMERIC PARAMETER AREA: SIDE, SIDE + SMALL BOTTOM, SIDE + LARGE BOTTOM

Select the area for displaying numeric values on the home screen.

SIDE: The numeric values are displayed at the left side of the home screen.

SIDE + SMALL BOTTOM: The numeric values are displayed at the left and bottom of the home screen. The values at the bottom of the screen are small.

SIDE + LARGE BOTTOM: The numeric values are displayed at the left and bottom of the home screen. The values at the bottom of the screen are large.

3. CHANGING SYSTEM SETUP WINDOW SETTINGS

SIDE

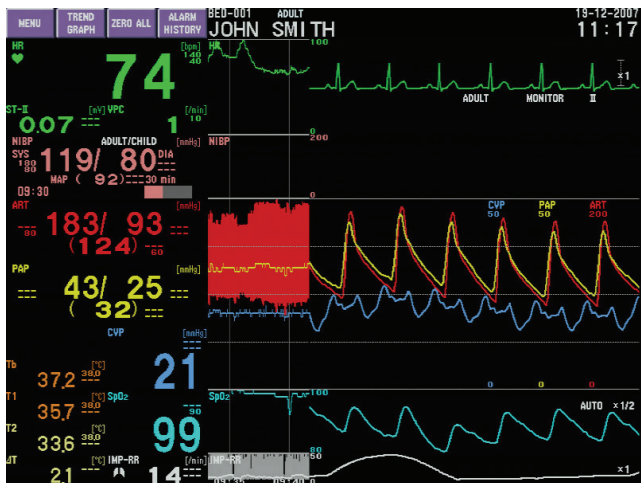

SIDE + SMALL BOTTOM

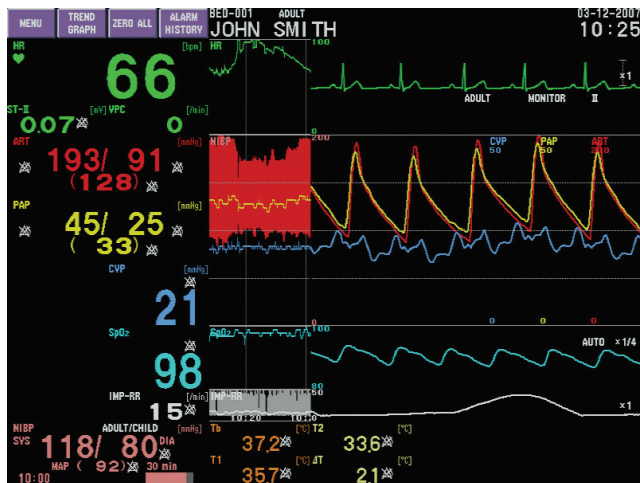

SIDE + LARGE BOTTOM

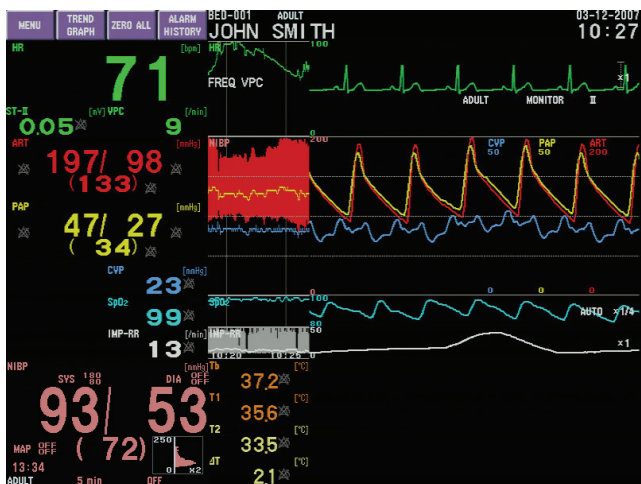

LARGE NUMERIC SCREEN LAYOUT: 2 × 2, 3 × 4

Select the layout type for the LARGE NUMERIC window.

2 × 2

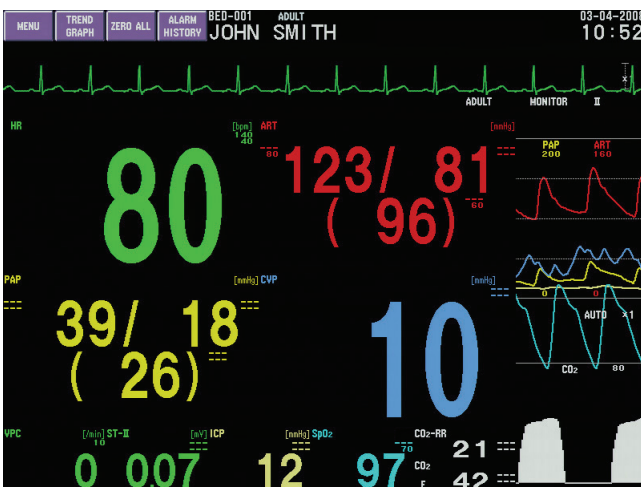

3 × 4



NUMERIC PARAMETER AREA (SIDE): LEFT, RIGHT

Select whether to display the numeric data on the left or right side of the home screen.

LEFT

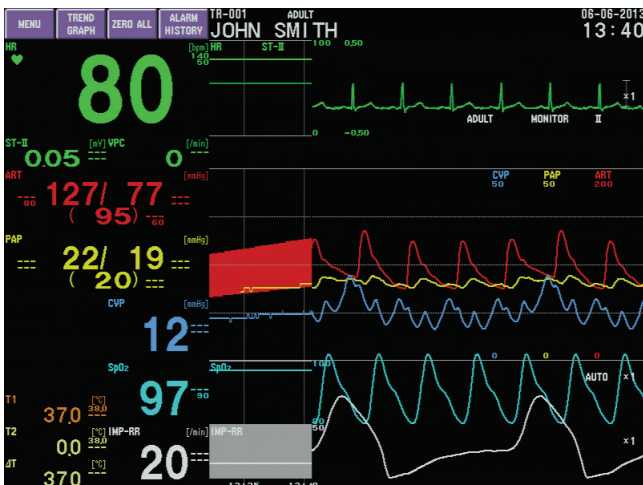

RIGHT

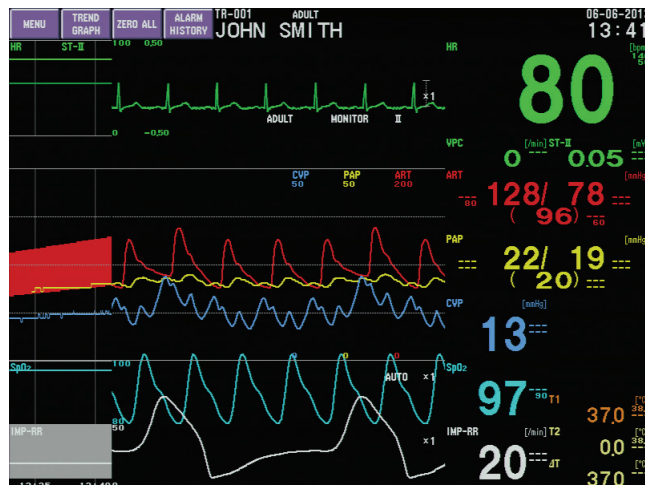

NIBP NUMERIC AREA: BOTTOM, SIDE, BELOW PRESS

Select the area for displaying NIBP numeric data on the home screen.

BOTTOM:

The NIBP numeric data is displayed at the bottom of the home screen when <NUMERIC PARAMETER AREA> is set to SIDE + SMALL BOTTOM or SIDE + LARGE BOTTOM.

SIDE:

The NIBP numeric data displayed at the left or right side of the home screen when <NUMERIC PARAMETER AREA> is set to SIDE + SMALL BOTTOM or SIDE + LARGE BOTTOM.

BELOW PRESS (On, Off): The NIBP numeric data is displayed below the IBP numeric data when <NUMERIC PARAMETER AREA> is set to SIDE or <NIBP NUMERIC AREA> is set to BOTTOM.

PRESS COMMON SCALE AREA: NORMAL, LARGE

Select the IBP waveform display area on the home screen.

NORMAL

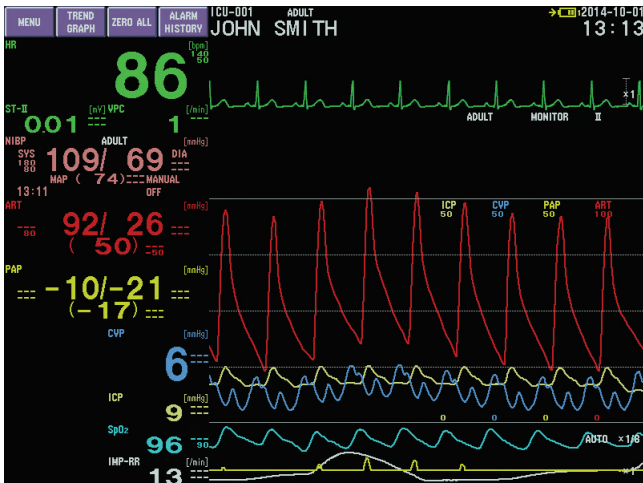

LARGE

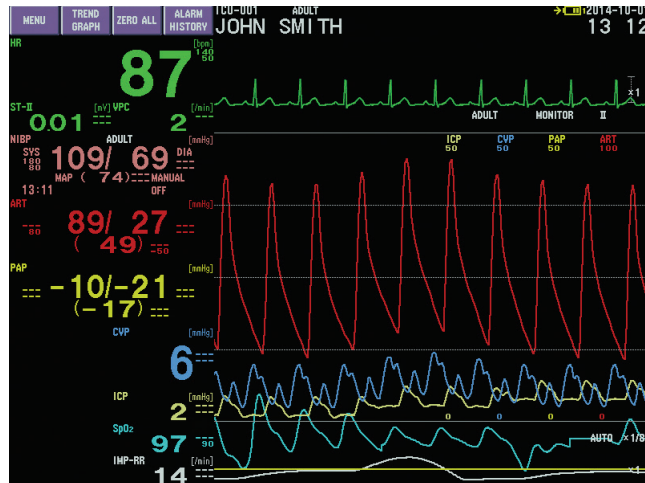

3. CHANGING SYSTEM SETUP WINDOW SETTINGS

- NORMAL:** Display the IBP waveform in the IBP waveform display area.
- LARGE:** Expand the IBP waveform display area to the NIBP waveform display area and show the IBP waveform in a larger area.

VOLUME Page

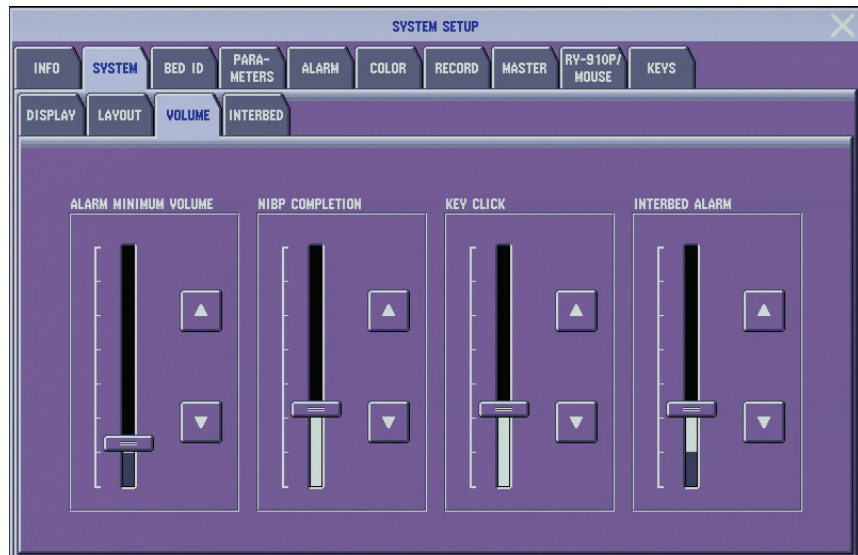

ALARM MINIMUM VOLUME

Set the minimum volume for the alarm sound.

NIBP COMPLETION

Set the volume for the NIBP measurement completion sound. The NIBP measurement completion sound is enabled when <COMPLETION SOUND> on the NIBP page of the PARAMETERS window is set to NK1 or NK2. When <COMPLETION SOUND> is set to Off or the volume is set to minimum, there is no sound.

KEY CLICK

Set the volume for the click sound when a key on the screen is touched. When set to minimum, there is no click sound.

INTERBED ALARM

Set the volume for the interbed alarm sound. The interbed alarm sound is enabled when <INTERBED ALARMS TO DISPLAY> on the INTERBED page of the SYSTEM window is set to ALL, CRISIS AND WARNING, or CRISIS. When <INTERBED ALARMS TO DISPLAY> is set to NONE, there is no sound.

INTERBED Page



3

INTERBED ALARMS TO DISPLAY: ALL, CRISIS AND WARNING, CRISIS, NONE

Select which alarm priorities generate an interbed alarm on this bedside monitor. The alarm sound is three pings.

- | | |
|---------------------|---|
| ALL: | All alarm priorities are indicated on this bedside monitor. |
| CRISIS AND WARNING: | The crisis and warning alarm priorities are indicated on this bedside monitor. |
| CRISIS: | The crisis alarm priority is indicated on this bedside monitor. |
| NONE: | There is no sound indication but the bed ID of the alarmed bed is indicated at the upper right corner of the home screen on this bedside monitor. |

When alarms occur at several interbed beds at the same time, the alarms are displayed on this bedside monitor one after the other.

NOTE

When ALL, CRISIS AND WARNING, or CRISIS is selected, the alarm sounds near the patient. If the sound indication is unwanted, select NONE.

BED ID Window

Enter an identification name for the bed. Up to 10 alphanumeric characters can be entered.

CAUTION

When the monitor is connected to a central monitor network, set the Bed Name (Bed ID) and Group Name on the monitor. Otherwise, the default settings are used for the bed name and group name and the bed may be incorrectly identified on the central monitor.

1. Touch the EDIT key. The keyboard appears.



2. Touch the desired letters and numbers to enter the bed ID.



3. Touch the ENT key to register the bed ID.

PARAMETERS Window

The PARAMETERS window has eight pages.

3

ECG Page

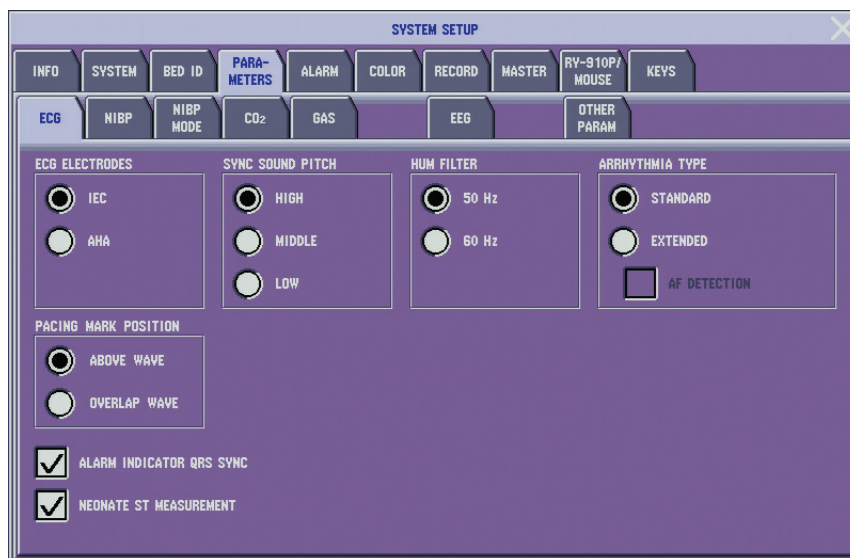

ECG ELECTRODES: IEC, AHA

Select the electrode lead type.

IEC: R, L, F, RF, C

AHA: RA, LA, LL, RL, V

SYNC SOUND PITCH: HIGH, MIDDLE, LOW

Select high, middle, or low pitch synchronized sound.

HUM FILTER: 50 Hz, 60 Hz

Select the hum filter.

50 Hz: Set to 50 when operating only in 50 Hz area

60 Hz: Set to 60 when operating only in 60 Hz area

NOTE

Make sure that the appropriate line frequency is selected. Otherwise, noise may interfere on the ECG waveforms.

3. CHANGING SYSTEM SETUP WINDOW SETTINGS

ARRHYTHMIA TYPE: STANDARD, EXTENDED

There are 2 patterns of arrhythmia analysis. Normally, use “STANDARD”.

STANDARD: ASYSTOLE, VF, VT, VPC RUN, TACHYCARDIA, BRADYCARDIA, COUPLET, EARLY VPC, BIGEMINY, FREQ VPC, VPC

EXTENDED: ASYSTOLE, VF, VT, EXT TACHY, EXT BRADY, VPC RUN, V BRADY, SV TACHY, TACHYCARDIA, BRADYCARDIA, PAUSE, COUPLET, EARLY VPC, MULTIFORM, V RHYTHM, BIGEMINY, TRIGEMINY, FREQ VPC, VPC, AF*, IRREGULAR RR, PROLONGED RR, NO PACER PULSE, PACER NON-CAPTURE

* Not available for BSM-6000K series.

NOTE

- If arrhythmia type is changed to “EXTENDED” and the bedside monitor is connected via network to a central monitor that has old software, the “Lost communication with instruments in the network” message appears on the bedside monitor and the bedside monitor cannot be monitored on the central monitor.
- When the data is transported from the source monitor whose arrhythmia type is set to STANDARD to the destination monitor whose arrhythmia type is set to EXTENDED, the STANDARD settings of the source monitor are copied to the destination monitor. However, depending on the other various settings, the STANDARD settings may be changed. Make sure to check the arrhythmia alarm settings before monitoring on the destination monitor.

AF DETECTION: On, Off

This setting is not available on BSM-6000K series bedside monitors.

AF detection can be used when AF DETECTION is set to On and when <PROTOCOL> on the NETWORK window in the SYSTEM CONFIGURATION screen is set to 2ND GEN.

NOTE

If <PROTOCOL> is changed to 2ND GEN and the bedside monitor is connected via network to a central monitor that has old software, the “Lost communication with instruments in the network” message appears on the bedside monitor and the bedside monitor cannot be monitored on the central monitor.

PACING MARK POSITION: ABOVE WAVE, OVERLAP WAVE

Select the pacing mark position on the ECG waveform displays on the home screen and ECG window.

ABOVE WAVE: Pacing mark is displayed above the wave.

OVERLAP WAVE: Pacing mark is displayed overlapping wave.

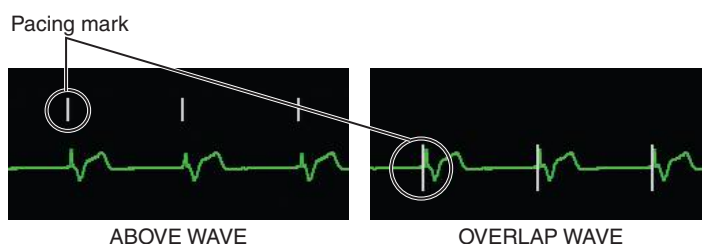
**ALARM INDICATOR QRS SYNC**

When this is checked, the green lamp of the alarm indicator blinks in synchronization with the patient's QRS.

NEONATE ST MEASUREMENT

When the patient type is set to NEONATE, ST measurement can be turned on or off.

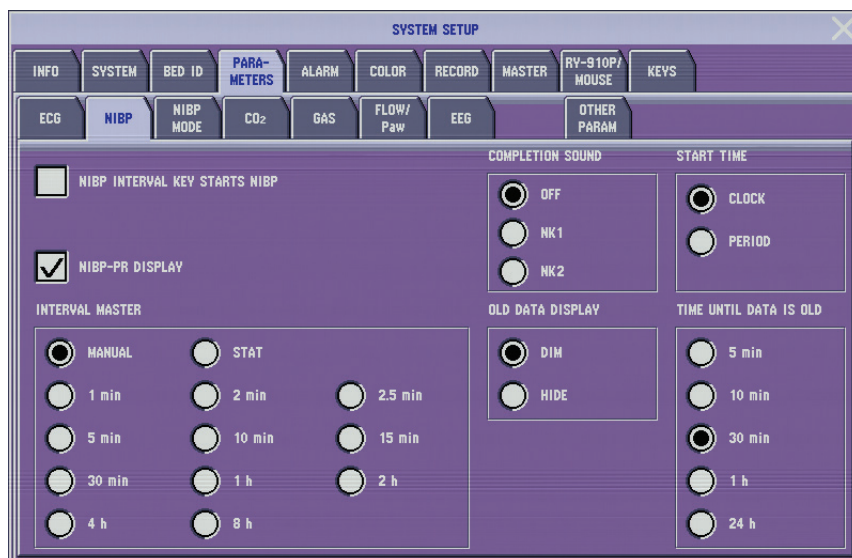
NIBP Page**NIBP INTERVAL KEY STARTS NIBP**

When this is checked, the first NIBP measurement starts in auto measurement when [NIBP Interval] key is pressed to select the interval.

SIM: On, Off

Select On when using SIM mode for NIBP. This setting is only available when the site is OR.

COMPLETION SOUND: OFF, NK1, NK2

When set to NK1 or NK2, a sound is generated when NIBP measurement is complete. The volume for this sound is set at <NIBP COMPLETION> on the DISPLAY-VOLUME page.

3. CHANGING SYSTEM SETUP WINDOW SETTINGS

START TIME: CLOCK, PERIOD

Select the interval measurement mode from CLOCK and PERIOD.

CLOCK: Measurement begins at the nearest preset interval based on the clock hour.

PERIOD: Measurement begins immediately.

Example

When you start periodic measurement at 12:03 at 5 min interval, measurement is performed at:

CLOCK: 12:03, 12:05, 12:10, 12:15 ...

PERIOD: 12:03, 12:08, 12:13 ...

When you start periodic measurement at 12:03 at 30 min interval, measurement is performed at:

CLOCK: 12:03, 12:30, 13:00, 13:30 ...

PERIOD: 12:03, 12:33, 13:03 ...

NIBP-PR DISPLAY: On, Off

Select whether to display the pulse rate on the NIBP display area of the home screen.

INTERVAL MASTER: MANUAL, STAT, SIM, 1, 2, 2.5, 5, 10, 15, 30 min, 1, 2, 4 or 8 h

Select the initial NIBP measurement mode. The NIBP measurement mode returns to this master setting when:

- The monitor power is off for more than 30 minutes and <SHOW ADMIT CONFIRMATION WINDOW> is turned off in the SYSTEM CONFIGURATION screen.
- The patient is admitted or discharged.

SIM mode is only available when the site is OR and <SIM> is turned on.

OLD DATA DISPLAY: DIM, HIDE

Select whether to dim or hide the NIBP data on the home screen when the time in <TIME UNTIL DATA IS OLD> elapses after the last NIBP measurement.

TIME UNTIL DATA IS OLD: 5 min, 10 min, 30 min, 1 h or 24 h

Select how long to wait after NIBP measurement to dim or hide the NIBP data on the home screen.

NOTE

When 24 h is selected, the NIBP data is hidden 24 hours after measurement even when DIM is selected for <OLD DATA DISPLAY>.

NIBP MODE Page

The NIBP MODE page has five tabs.

STAT Tab

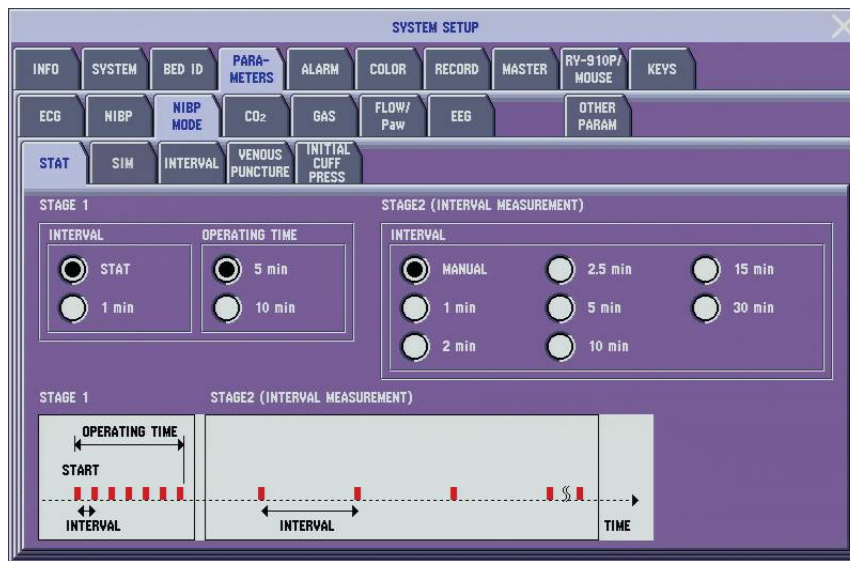

Set the program for the STAT mode measurement.

The STAT mode is for measuring blood pressure during induction of general anesthesia. There are two stages. In <STAGE 1>, repetitive measurement is performed at the interval set for <INTERVAL> for the period set for <OPERATING TIME>. After stage 1 finishes, periodic measurement starts at the interval set for <STAGE 2>.

Setting Items

- STAGE 1 INTERVAL: STAT/1 min*
- STAGE 1 OPERATING TIME: 5 min/10 min
- STAGE 2 INTERVAL: MANUAL/1 min/2 min/2.5 min/5 min/
10 min/15 min/30 min

* 1 minute interval measurement reduces burden on the patient.

3. CHANGING SYSTEM SETUP WINDOW SETTINGS

SIM Tab

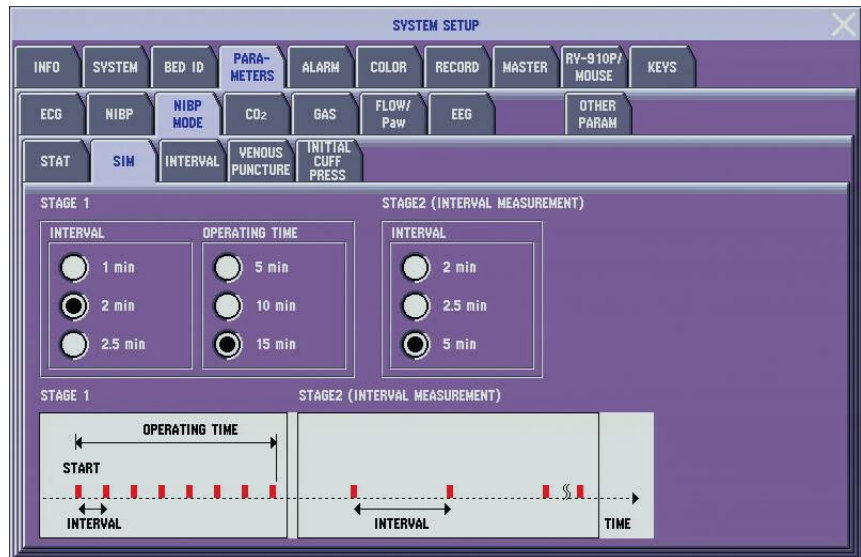

Set the program for the SIM mode measurement. This tab appears only when <SIM> is set to On on the NIBP page.

The SIM mode is for measuring blood pressure during infusion of local anesthesia such as spinal anesthesia (also called lumbar anesthesia or subarachnoid block) and epidural anesthesia. There are two stages. In <STAGE 1>, repetitive measurement is performed at the interval set for <INTERVAL> for the period set for <OPERATING TIME>. After stage 1 finishes, periodic measurement starts at the interval set for <STAGE 2>.

Setting Items

STAGE 1 INTERVAL: 1 min/2 min/2.5 min

STAGE 1 OPERATING TIME: 5 min/10 min/15 min

STAGE 2 INTERVAL: 2 min/2.5 min/5 min

INTERVAL Tab

Select the measurement mode to be displayed on the NIBP INTERVALS window which appears on the left part of the screen when the [NIBP Interval] key is pressed.

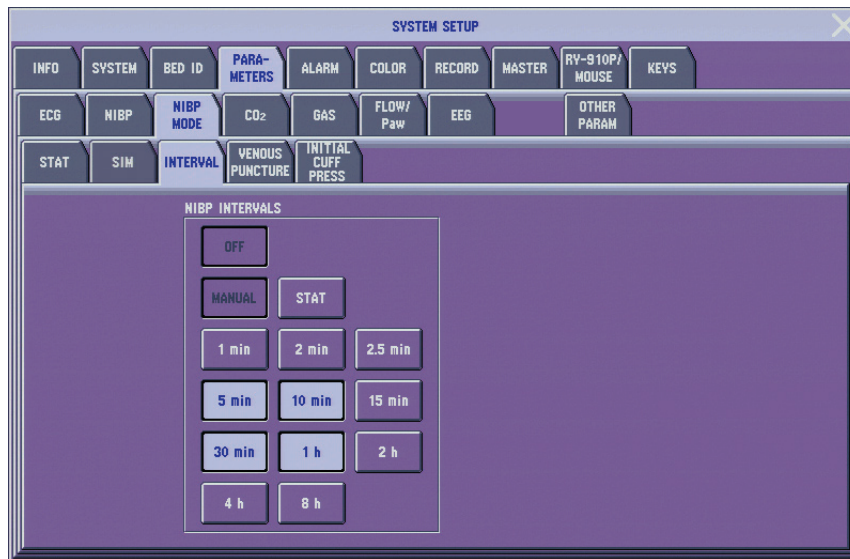

VENOUS PUNCTURE Tab

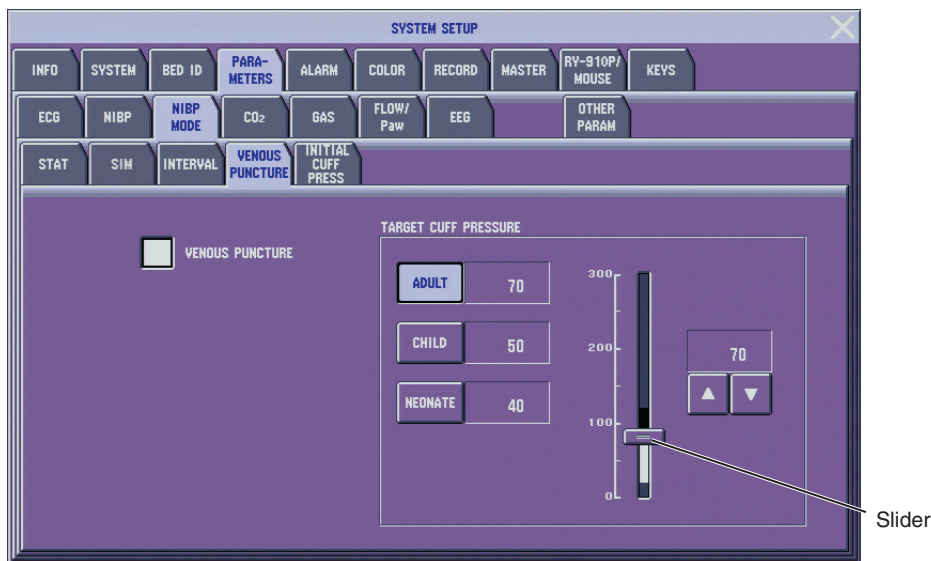

VENOUS PUNCTURE

When this is checked, venous puncture mode is available for NIBP.

TARGET CUFF PRESSURE

Set the maximum cuff pressure for each patient type in venous puncture mode.

1. Select the patient type by touching the ADULT, CHILD or NEONATE key.
2. Touch and drag the slider to select the cuff pressure. Use the ▲ or ▼ key to adjust setting.

3. CHANGING SYSTEM SETUP WINDOW SETTINGS

INITIAL CUFF PRESS Tab

Set the master setting for the initial cuff inflation pressure. The initial cuff inflation pressure on the NIBP window returns to this master setting when:

- The monitor power is off for more than 30 minutes and <SHOW ADMIT CONFIRMATION WINDOW> is turned off in the SYSTEM CONFIGURATION screen.
- The patient is admitted or discharged.

NOTE

When the air hose for neonates (1.5 m) is connected to the monitor and the initial cuff pressure is set to 125 mmHg or more, the actual pressure may be less than the setting.

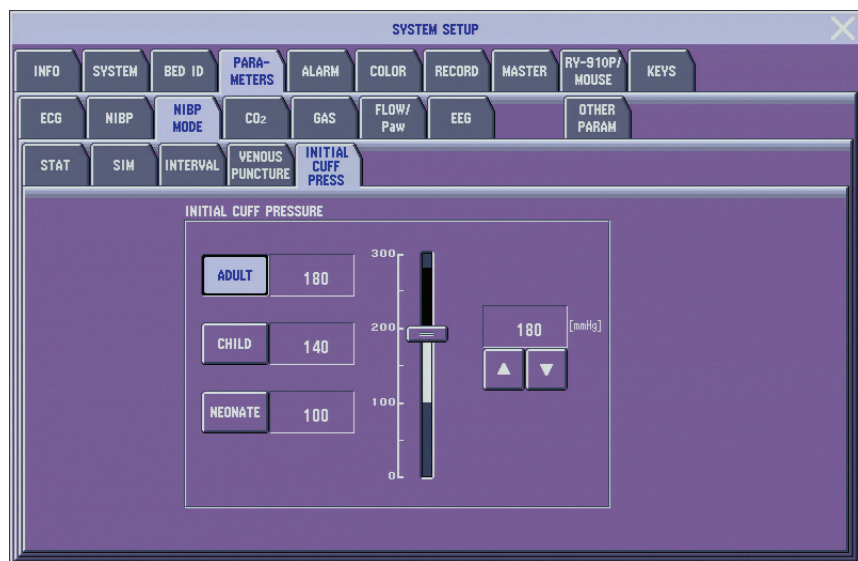

CO₂ Page

Use this page for inspecting CO₂ measurement accuracy. For details, refer to the Service Manual.

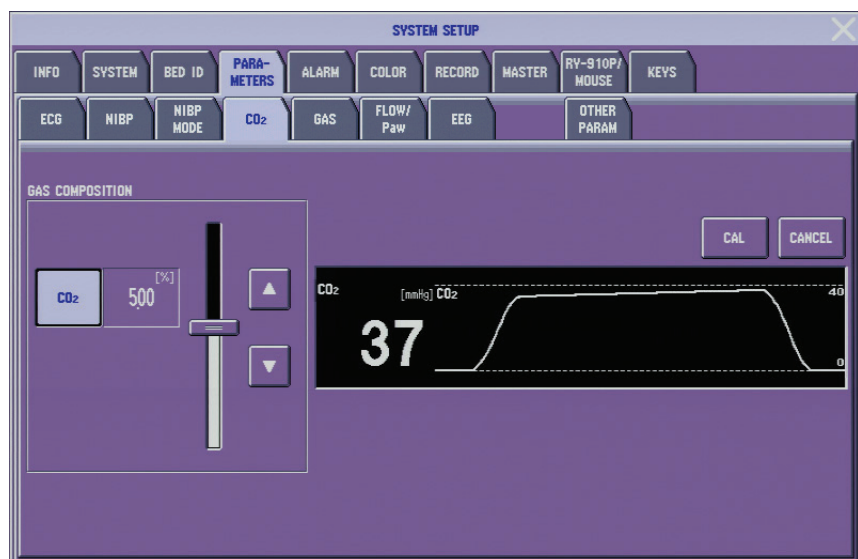

GAS Page

The GAS page has three tabs.

NOTE

GF-120PA or GF-220R multigas/flow unit is not available for the BSM-6000A series.

MAINTENANCE Tab

Use this page for gas calibration. For details, refer to the Service Manual.

CAUTION

When the monitoring value is not appropriate, perform gas calibration. Perform gas calibration once a year for stable measuring accuracy.

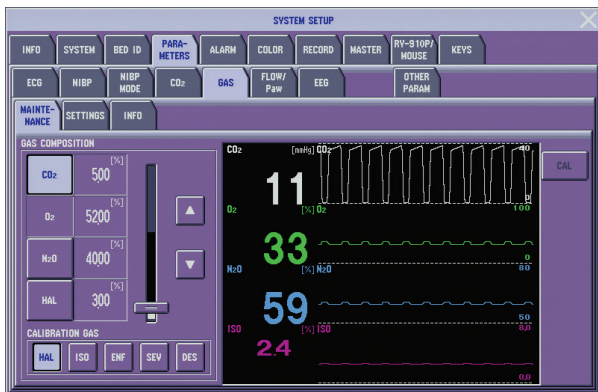

MAINTENANCE page when GF-110PA or GF-120PA is connected



MAINTENANCE page when GF-210R or GF-220R is connected

SETTINGS Tab

Set the settings on the SETTINGS tab when monitoring anesthetic gas with a GF-110PA or GF-210R multigas unit or GF-120PA or GF-220R multigas/flow unit.

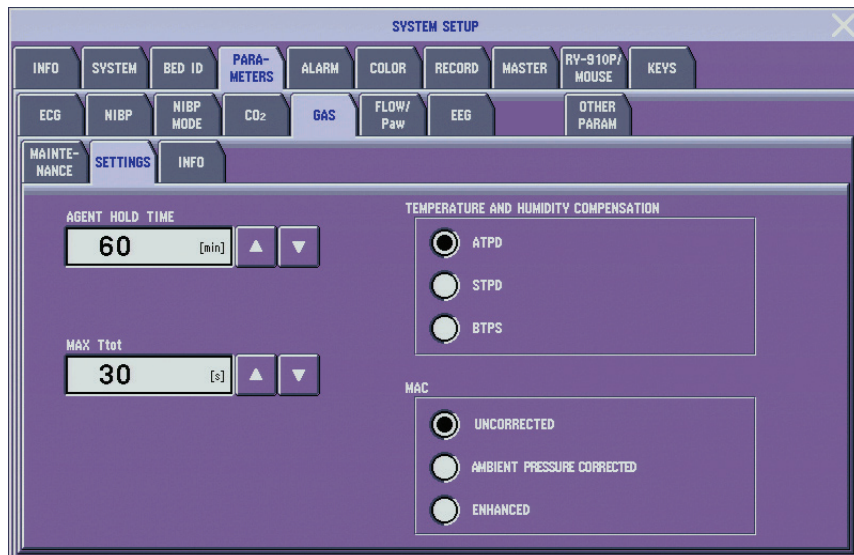

3. CHANGING SYSTEM SETUP WINDOW SETTINGS

AGENT HOLD TIME: 10 to 60 min (5 min steps)

Set the time to delete the anesthetic agent data from the home screen after the end of gas monitoring.

MAX Ttot: 20 to 40 s (5 s steps)

Set the time to display spontaneous value instead of Fi/ET values for gas values when there is apnea.

TEMPERATURE AND HUMIDITY COMPENSATION: ATPD, STPD, BTPS

Select the temperature and humidity for compensating the gas measurement values (it is assumed that the sensor temperature is 22°C (71.6°F) and humidity 40%).

ATPD: Ambient Temperature 25°C (77°F), atmospheric Pressure, Dry (0%)

STPD: Standard Temperature 0°C (32°F), 1 atmospheric Pressure, Dry (0%)

BTPS: Body Temperature 37°C (98.6°F), atmospheric Pressure, Saturated (100%)

MAC: UNCORRECTED, AMBIENT PRESSURE CORRECTED, ENHANCED

NOTE

This setting is not available on the BSM-6000A series.

Select the type of MAC to be displayed. When using an AG-920RA/K Multigas Unit, uncorrected MAC is always displayed. For details on the MAC calculation method when the AG-920RA/K Multigas Unit is used, refer to the Operator's Manual.

For details on the MAC calculation method when the GF-110PA, GF-120PA, GF-210R or GF-220R Multigas Unit is used, refer to the Multigas Unit Operator's Manual.

UNCORRECTED:	Displays uncorrected MAC. Labeled "MAC" on the screen.
AMBIENT PRESSURE CORRECTED:	Displays ambient pressure-corrected MAC. Labeled "MAC-Ambnt" on the screen.
ENHANCED:	Displays enhanced MAC correction. Labeled "MAC-Enhnc" and "MAC-Awake" on the screen.

INFO Tab

The INFO tab shows information about the GF-110PA or GF-210R multigas unit or GF-120PA or GF-220R multigas/flow unit. For details, refer to the Service Manual.



INFO page when GF-120PA is connected



INFO page when GF-220R is connected

FLOW/Paw Page

The FLOW/Paw page has four tabs.

NOTE

GF-120PA and GF-220R multigas/flow unit are not available for BSM-6000A series.

CAL Tab

Use this page for gas calibration. For details, refer to the Service Manual.

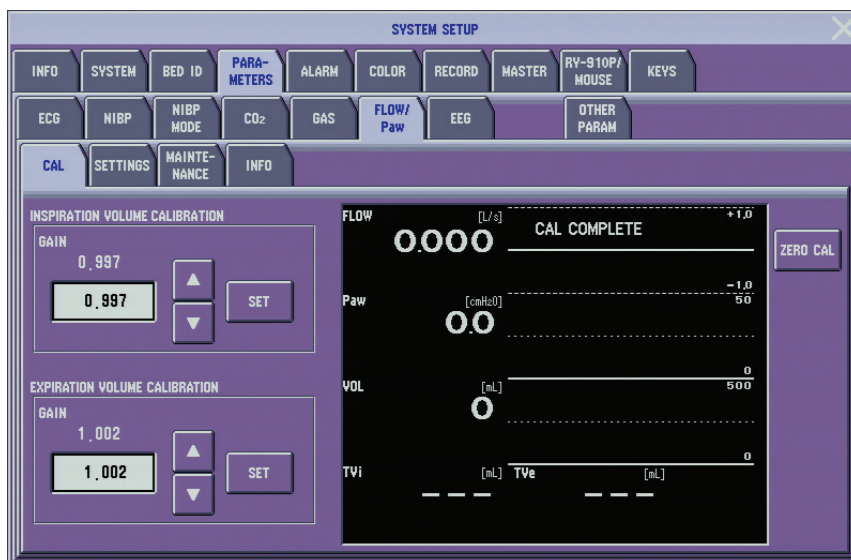

3. CHANGING SYSTEM SETUP WINDOW SETTINGS

SETTINGS Tab

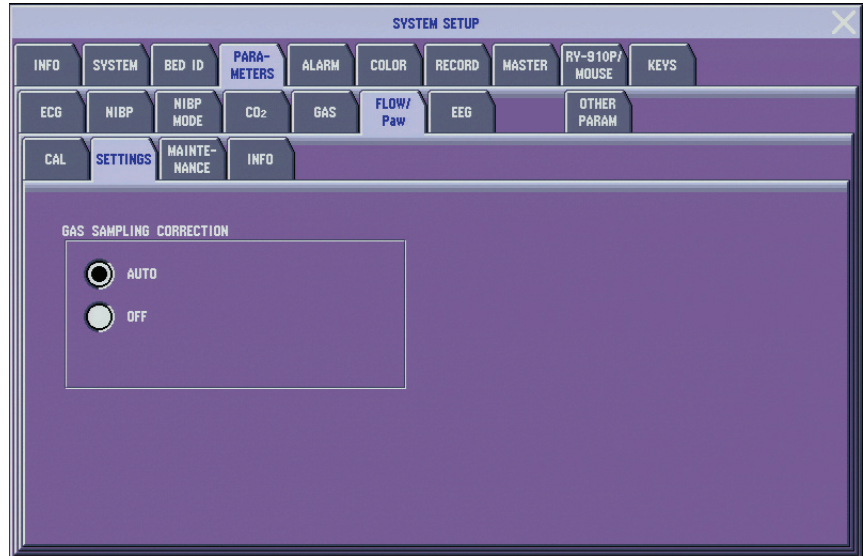

GAS SAMPLING CORRECTION: AUTO, OFF

This setting is available only when using a GF-120PA or GF-220R multigas/flow unit. When the sampling line for gas monitoring is attached to the sampling port on the flow adapter or connected between the flow tube and patient, there will be a difference between the ventilation volume setting on the anesthetic machine and the actual ventilated volume of the patient because of the gas sampled by the multigas/flow unit. This difference is compensated for in flow measurement when this item is set to AUTO. For example, if the sampling volume is set to 200 mL/min on the GAS window, 3.3 mL/min is subtracted from the measured flow value. The flow volumes are also calculated from the compensated flow value.

AUTO: When <GAS MEASUREMENT> on the GAS window is set to On, the flow value is compensated whenever patient respiration is detected by the monitor.

OFF: No compensation.

MAINTENANCE Tab

Use this page for inspecting the GF-120PA or GF-220R multigas/flow unit. For details, refer to Service Manual.

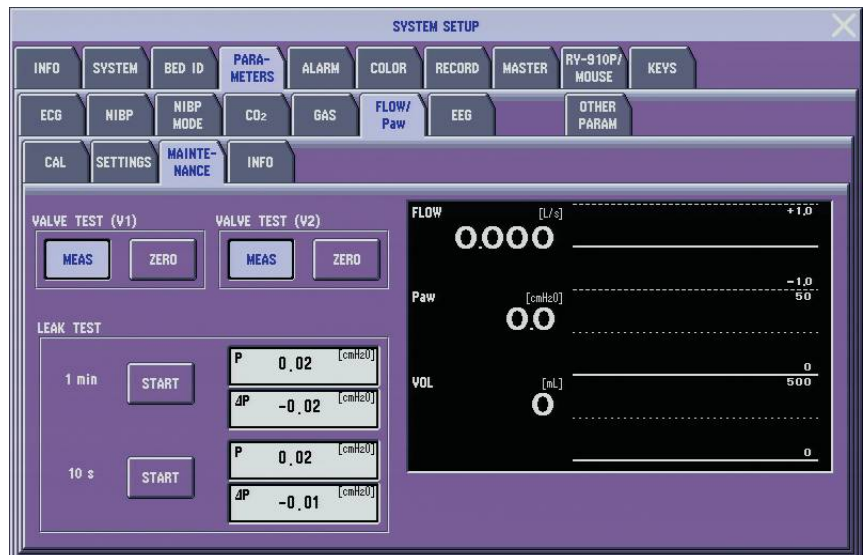

INFO Tab

The INFO tab shows the model and software version of the GF-120PA or GF-220R multigas/flow unit.

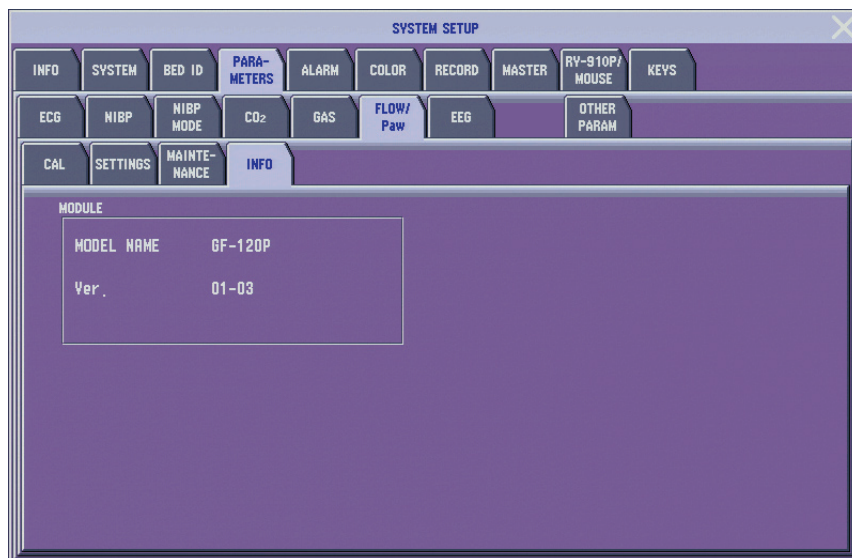

EEG Page

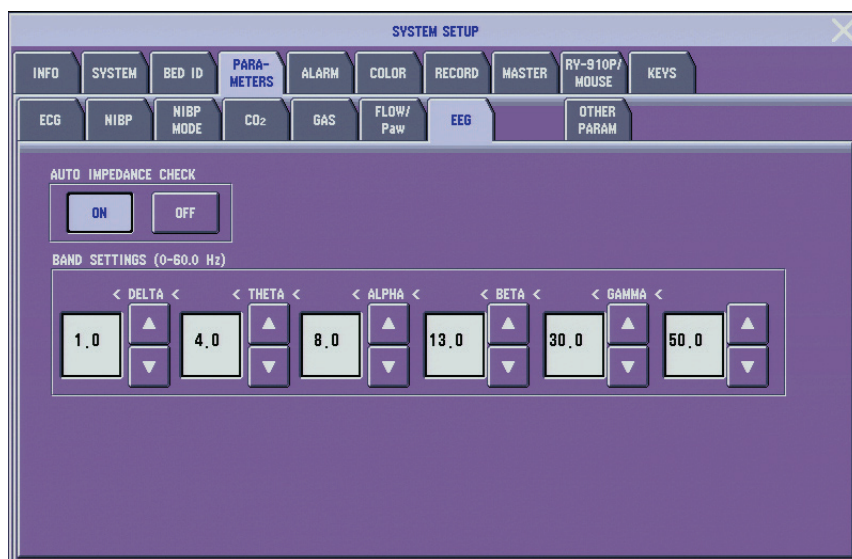

AUTO IMPEDANCE CHECK: ON, OFF

When auto check is turned On, measurement signals of two frequencies higher than the EEG frequency band are applied to check impedance while measuring EEG. If the result is not “PASS”, the “CHECK ELECTRODES” or “HIGH IMPEDANCE” message appears on the screen.

The impedance for the Z electrode cannot be automatically checked. Check impedance for the Z electrode manually.

3. CHANGING SYSTEM SETUP WINDOW SETTINGS

CAUTION

Never check the skin-electrode impedance with the needle electrode inserted in the patient. Failure to follow this caution causes electrical burn where electrodes are inserted.

NOTE

It is recommended to use auto impedance check function so that electrode off, lead disconnection and high impedance of an electrode can be automatically detected. However, noise from the automatic impedance check may affect other devices. In that case, set the automatic impedance check to Off.

BAND SETTINGS: 0 to 60.0 Hz

If necessary, change the frequency band setting.

OTHER PARAM Page

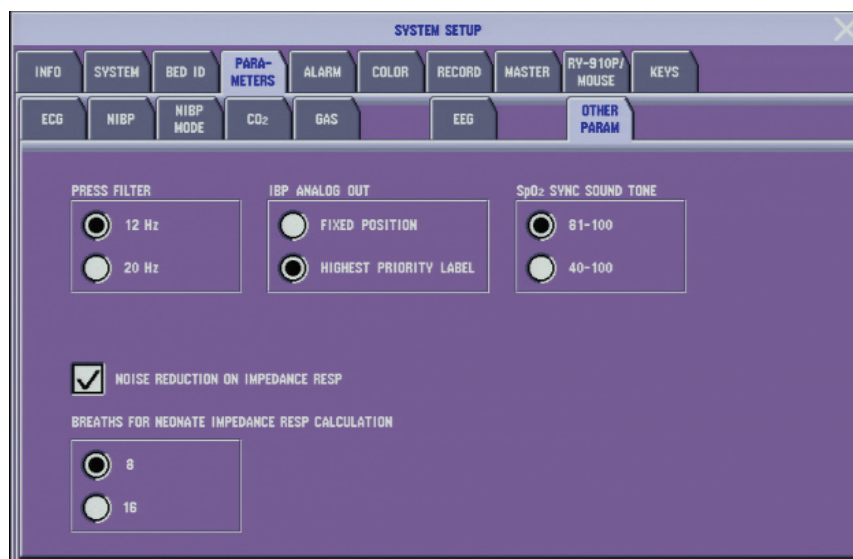

The above screen example is for BSM-6000A series.

PRESS FILTER: 12 Hz, 20 Hz

Select the noise filter for IBP monitoring. For normal monitoring, set the filter to 12 Hz. To see the IBP waveforms in detail, set the filter to 20 Hz.

IBP ANALOG OUT: FIXED POSITION, HIGHEST PRIORITY LABEL

Select the IBP output condition.

FIXED POSITION: IBP line connected to the top MULTI socket is used for IBP output.

HIGHEST PRIORITY LABEL: IBP line of the highest priority label is used for IBP output.

Label priority: ART > ART2 > RAD > DORS > AO > FEM > UA > LVP > P1 > P2 > P3 > P4 > P5 > P6 > P7

SpO₂ SYNC SOUND TONE: 81-100, 40-100

When SpO₂ is selected for the SYNC PITCH setting, select the range of SpO₂. The pitch changes with each 1% change in SpO₂.

81-100 : The pitch changes between 100%SpO₂ and 81%SpO₂ in SpO₂ value (20 steps).

40-100: The pitch changes between 100%SpO₂ and 40%SpO₂ in SpO₂ value (61 steps).

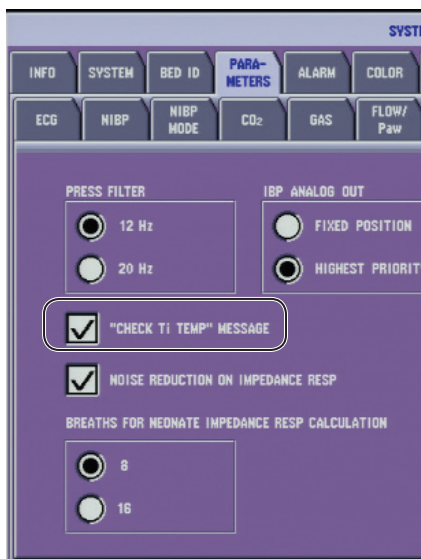
**“CHECK Ti TEMP” MESSAGE: On, Off**

This setting is only available for BSM-6000K series bedside monitor.

Select whether to display a confirmation message when the injectate temperature is not measured at CO measurement start.

On: When the injectate temperature is not measured at CO measurement start, the monitor does not perform CO measurement. The “CHECK Ti TEMP” message and “---” appear on the screen.

Off: When the injectate temperature is not measured at CO measurement start, the monitor assumes the injectate temperature to be 0 °C and performs CO measurement. “0 °C” appears on the screen.

NOISE REDUCTION ON IMPEDANCE RESP

In the impedance method, noise from the heart beat may interfere on the respiration waveform due to electrode position, and the respiration rate may increase to almost the same rate as the heart rate. In such a case, set this setting to On to reduce noise interference on the respiration waveform.

If the respiration rate is miscounted in the thermistor method, set this item to Off.

NOTE

When this item is checked and the timing of the respiration and heart beat coincide, respiration rate might not be counted. In such a case, set this item to Off or check the patient’s respiration by observing the patient’s chest movement or the respiration waveform on the screen.

BREATHS FOR NEONATE IMPEDANCE RESP CALCULATION: 8, 16

When monitoring a neonate, you can select the 8 or 16 breaths for the impedance respiration calculation.

ALARM Window

The ALARM window has six pages.

SILENCE/SUSPEND Page

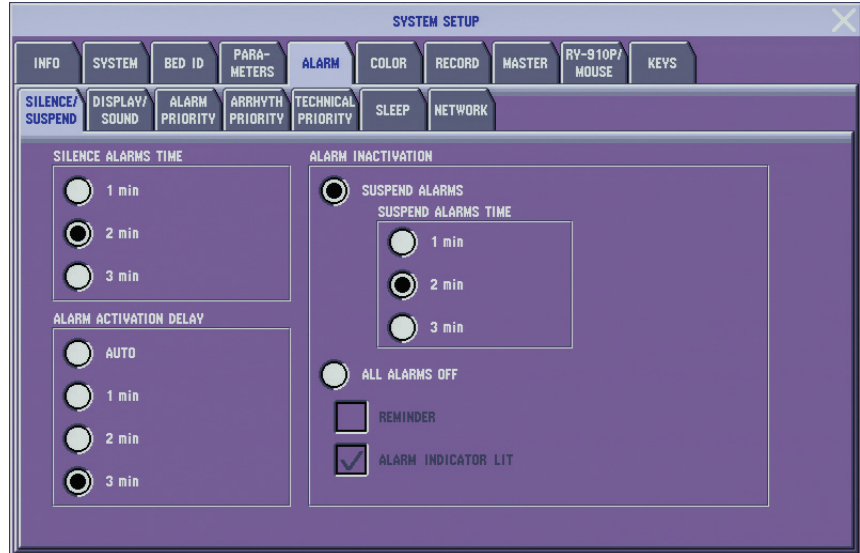

SILENCE/SUSPEND page when site is ICU/NICU

SILENCE ALARMS TIME: 1, 2 or 3 min

Select the interval for silencing an alarm.

ALARM ACTIVATION DELAY: AUTO, 1, 2 or 3 min

To prevent unnecessary alarms immediately after monitoring starts or monitoring resumes, alarm activation can be delayed for a short time. For details, refer to Operator’s Manual or Section 5 of the User’s Guide Part I.

AUTO: Alarm function activates when ECG, SpO₂ or IBP is monitored or NIBP is measured and a value is displayed.

1, 2, 3 min: Alarm function activates when one of the following requirements is met.

- ECG, SpO₂ or IBP is continuously monitored for the selected time.
- NIBP is measured.
- Heart rate becomes 0.

SILENCE SpO₂ ALARM: On, Off

This setting is not available for BSM-6000K series. Select what happens when another alarm occurs during SpO₂ alarm silence.

On: SpO₂ alarms are handled differently than other alarms. When an SpO₂ upper/lower limit alarm is silenced and another alarm which is not SpO₂ upper/lower limit alarm occurs during alarm silence, the alarm sound, indication and recording occur as usual. If another SpO₂ upper/lower limit alarm occurs during SpO₂ alarm silence, the alarm silence continues and the second SpO₂ alarm is not indicated.

Off: All alarm types are handled the same way. When an SpO₂ upper/lower limit alarm is silenced and another alarm occurs during alarm silence, the alarm sound, indication and recording occur as usual.

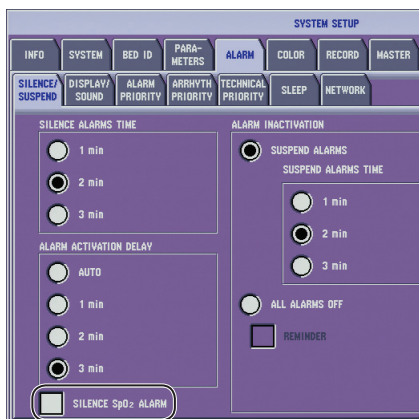

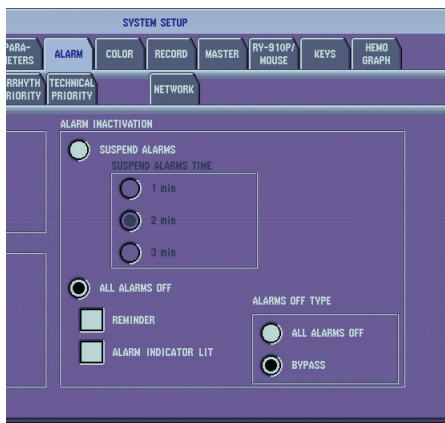

SILENCE/SUSPEND page when site is OR

ALARM INACTIVATION: SUSPEND ALARMS, ALL ALARMS OFF

Select the alarm off mode. The selected mode appears as the alarm off key on the MENU window.

SUSPEND ALARMS: Alarm function is suspended for the selected interval. Select the interval in the <SUSPEND ALARMS TIME> box.

ALL ALARMS OFF: Alarm function is suspended indefinitely. When the site is OR, select the alarm off type in the <ALARMS OFF TYPE> box.

REMINDER: When this item is checked, the “ALL ALARMS OFF” or “BYPASS” message blinks for 3 seconds every 3 minutes. When this item is unchecked, the message does not blink.

ALARM INDICATOR LIT: When this item is checked, the red lamp of the alarm indicator lights when all alarms are off.

The alarm off key on the MENU window

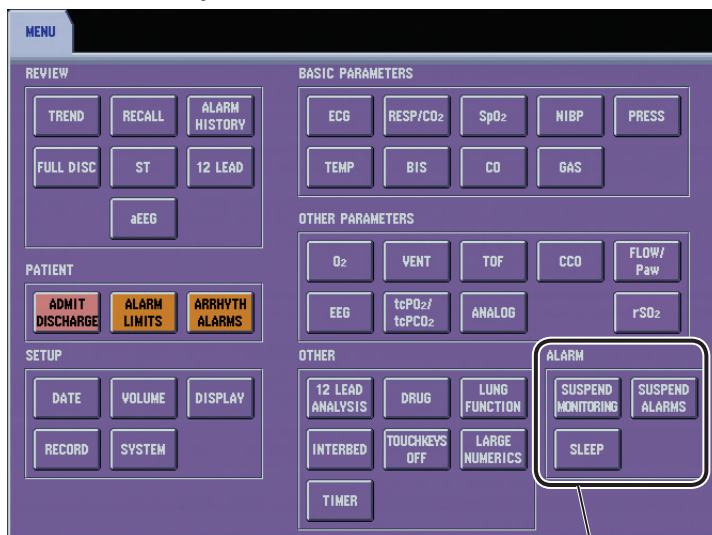

Alarm off keys

ALARM INACTIVATION setting	ICU/NICU site	OR site
SUSPEND ALARMS		
ALL ALARMS OFF		ALARMS OFF TYPE: BYPASS
		ALARMS OFF TYPE: ALL ALARMS OFF

3. CHANGING SYSTEM SETUP WINDOW SETTINGS

Alarm off function

SUSPEND MONITORING key

Use this key to temporarily stop patient monitoring for examination. When this key is touched, all alarms and NIBP STAT/SIM and auto measurements are suspended. Alarms resume when the SUSPEND MONITORING key is touched again or when the <ALARM ACTIVATION DELAY> condition is met.

SUSPEND ALARMS key

Use this key to suspend all alarms for the time set in <SUSPEND ALARMS TIME>.

BYPASS key

Use this key when the patient is connected to a heart-lung machine. When this key is touched, all alarms and NIBP STAT/SIM and auto measurements are indefinitely suspended. Touch the BYPASS key and touch the YES key on the confirmation window. Alarms resume when the BYPASS key is touched again.

ALL ALARMS OFF key

Use this key to suspend all alarms indefinitely. Touch the ALL ALARMS OFF key and touch the YES key on the confirmation window. Alarms resume when the ALL ALARMS OFF key is touched again.

DISPLAY/SOUND Page

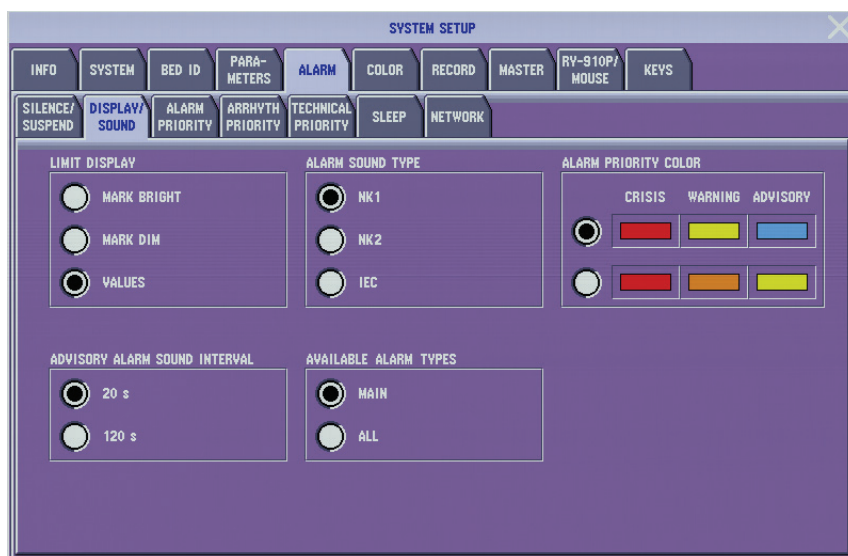

LIMIT DISPLAY: MARK BRIGHT, MARK DIM, VALUES

Select the alarm off mark display on the screen.

MARK BRIGHT: A normal brightness alarm off mark is displayed beside each parameter value whose vital signs alarm is set to OFF.

MARK DIM: A dimmed alarm off mark is displayed beside each parameter value whose vital signs alarm is set to OFF.

VALUES: The upper/lower alarm limits are displayed beside parameter values. For BSM-6000A series, when the limit is set to OFF, "OFF" is displayed. For BSM-6000K series, when the limit is set to OFF, "---" is displayed.

ALARM SOUND TYPE: NK1, NK2, IEC

Select the alarm sound standard.

NK1 and NK2: Nihon Kohden specified sound

IEC: IEC defined sound

ALARM SOUND TYPE setting	CRISIS	WARNING	ADVISORY
NK1	Continuous pip sound	Continuous bing bong sound	Single beep every 20 or 120 seconds
NK2	Continuous ping sound	Continuous ding ding sound	Single beep every 20 or 120 seconds
IEC	IEC standard (ceg-gC)	IEC standard (ceg)	IEC standard (ec)

ALARM PRIORITY COLOR

Select the combination of colors for the alarmed parameter when <DISPLAY COLOR MODE> is set to ALARM on the SYSTEM window.

ADVISORY ALARM SOUND INTERVAL: 20 s, 120 s

Select the sound interval for advisory level alarms.

AVAILABLE ALARM TYPES

MAIN: Only the main alarms and messages appear on the home screen.

ALL: All alarms and messages appears on the home screen. When the monitor is connected to a central monitor network, all alarms and messages are sent to the central monitor.

Refer to the “Screen Messages” section in the Operator’s Manual for details on the alarms and messages.

NOTE

- If <AVAILABLE ALARM TYPES> is changed to ALL and the bedside monitor is connected via network to a central monitor that has old software, the “Lost communication with instruments in the network” message appears on the bedside monitor and the bedside monitor cannot be monitored on the central monitor.
- <AVAILABLE ALARM TYPES> is fixed to ALL when <PROTOCOL> is set to 2ND GEN.

3. CHANGING SYSTEM SETUP WINDOW SETTINGS

ALARM PRIORITY Page

The ALARM PRIORITY page has three parameter tabs for each patient type: ADULT, CHILD and NEONATE.

Adult – Parameter page 1

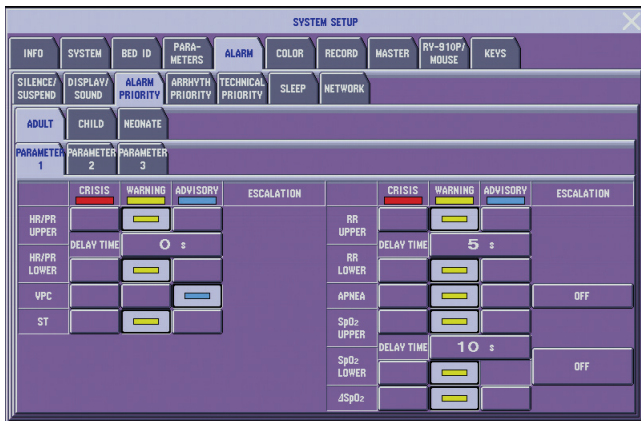

Adult – Parameter page 2



Adult – Parameter page 3



For TACHYCARDIA and BRADYCARDIA alarms, the alarm status continues depending on the alarm priority.

Select the alarm level and alarm indicator color for each parameter. The color combination depends on the <ALARM PRIORITY COLOR> setting on the DISPLAY/SOUND page.

CRISIS: The parameter data is highlighted in red with the sound selected in <ALARM SOUND TYPE> and a red blinking lamp.

WARNING: The parameter data is highlighted in yellow or orange (color selected in <ALARM PRIORITY COLOR>) with the sound selected in <ALARM SOUND TYPE> and a lit yellow lamp.

ADVISORY: The parameter data is highlighted in cyan or yellow (color selected in <ALARM PRIORITY COLOR>) with the sound selected in <ALARM SOUND TYPE> every 20 or 120 seconds and a lit cyan or yellow lamp. (The sound interval is selected in <ADVISORY PRIORITY ALARM SOUND INTERVAL> and the lamp color is selected in <ALARM PRIORITY COLOR>.)

NOTE

On BSM-6000A series, if <CRISIS VITAL ALARM MANAGEMENT> on the SYSTEM CONFIGURATION screen is turned on and “ALARM PRIORITY” of the following parameters is set to CRISIS, the alarm setting for that parameter is set to the alarm master setting and the alarm master cannot be set to OFF.

Parameters:

HR/PR UPPER, HR/PR LOWER, RR UPPER, RR LOWER, APNEA, SpO₂ UPPER, SpO₂ LOWER, SpO₂-2 UPPER, SpO₂-2 LOWER, CO₂ (E) UPPER, CO₂ (E) LOWER

HR/PR Delay Time

If there are too many heart rate or pulse rate alarms, you can set an alarm inhibit period to prevent transient changes in heart rate or pulse rate from triggering an alarm.

Example

HR/PR alarm level: WARNING
 HR/PR DELAY TIME: 5 s

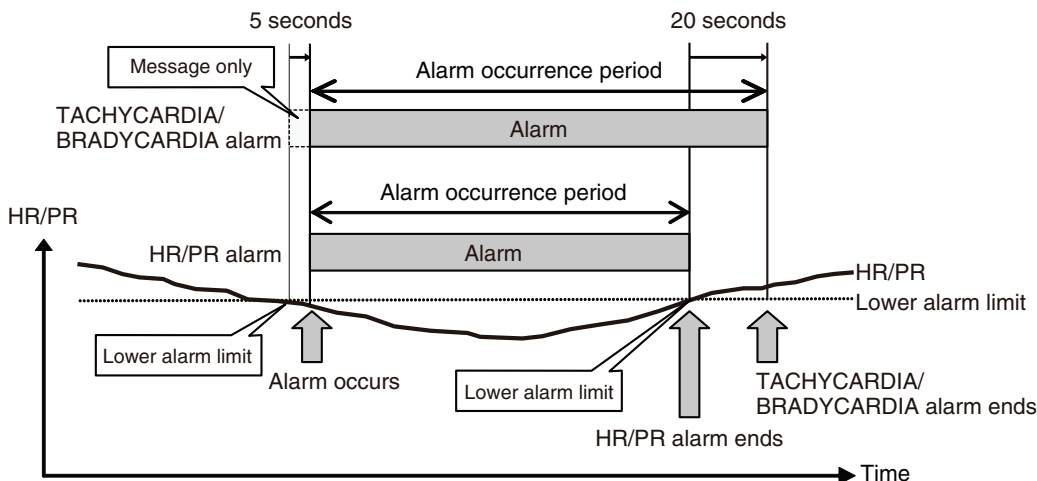

1. Touch the DELAY TIME key. The HR/PR DELAY TIME window opens.



2. Set the time with ▲ or ▼ key.
3. Touch the close button (✕) to close the HR/PR DELAY TIME window.

3. CHANGING SYSTEM SETUP WINDOW SETTINGS

RR Delay Time

If there are too many respiration alarms, you can set an alarm inhibit period to prevent transient changes in respiration rate from triggering an alarm.

Example
RR DELAY TIME: 5 s

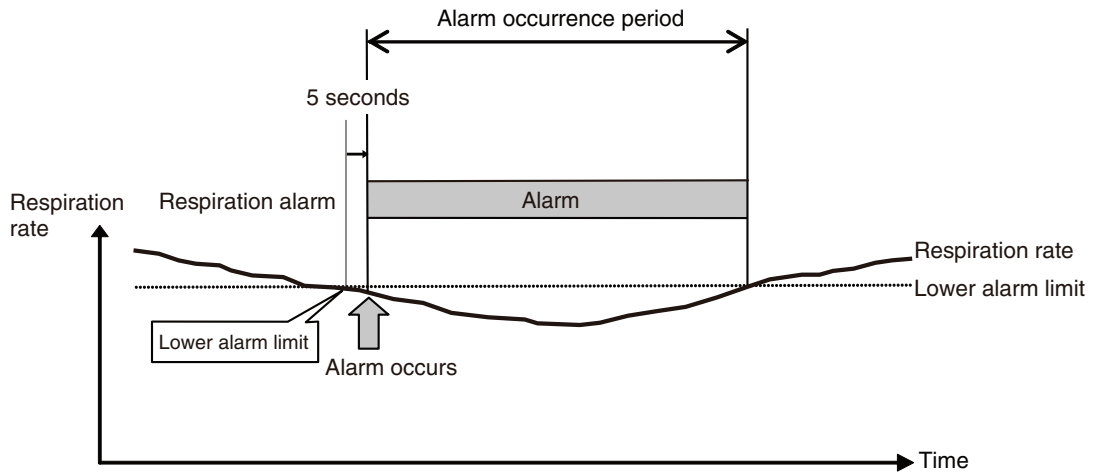

1. Touch the DELAY TIME key. The RR DELAY TIME window appears.



2. Set the time with ▲ or ▼ key.
3. Touch the close button (X) to close the RR DELAY TIME window.

Apnea Alarm Escalation

For APNEA alarms, an alarm escalation is available. When the setting is ON and no action is taken on an alarm for a selected duration, the alarm escalates to the selected level.

Example
APNEA alarm level: WARNING
Escalation setting: AFTER ELAPSED TIME: ON, TIME UNTIL ESCALATION: 30 s, PRIORITY: CRISIS

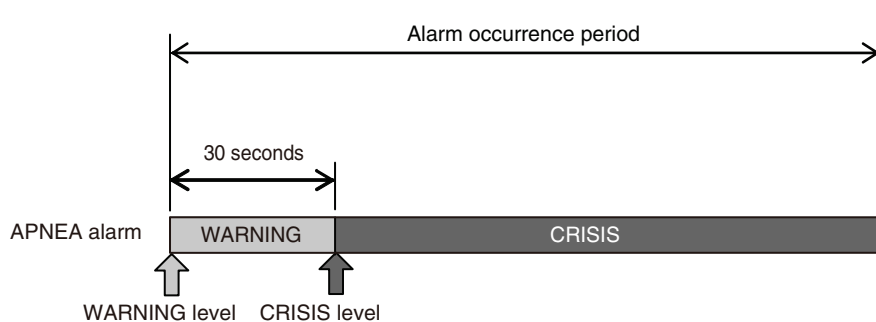

1. Touch the key in the ESCALATION column for APNEA. The APNEA ESCALATION window opens.

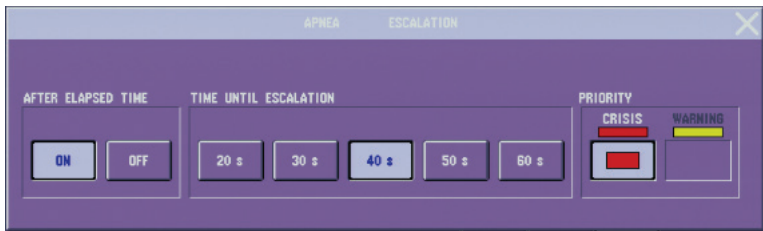

2. Select ON for <AFTER ELAPSED TIME>. The <TIME UNTIL ESCALATION> and <PRIORITY> setting become available.
3. Select <TIME UNTIL ESCALATION> and <PRIORITY>.
4. Touch the close button (X) to close the APNEA ESCALATION window.

SpO₂ Delay Time

If there are too many SpO₂ alarms, you can set an alarm inhibit period to prevent transient changes in SpO₂ value from triggering an alarm.

Example
SpO₂ DELAY TIME: 10 s

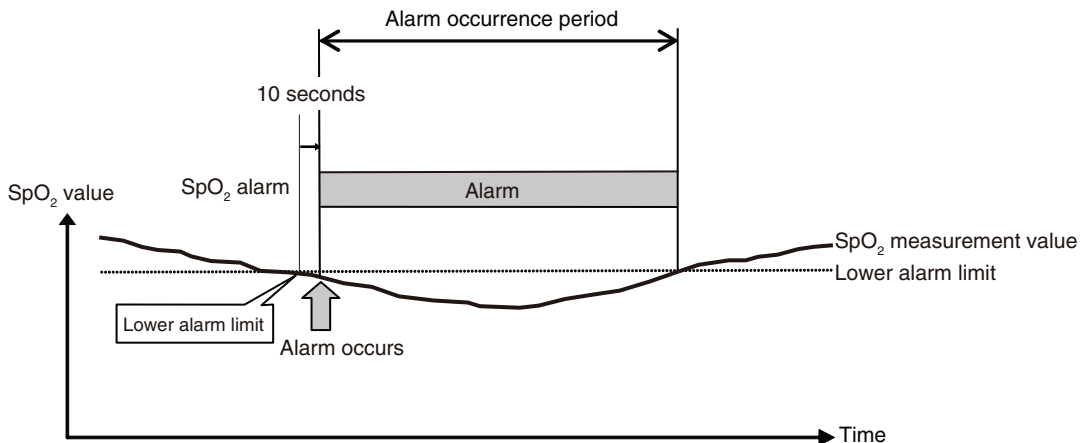

1. Touch the DELAY TIME key. The SpO₂ DELAY TIME window opens.

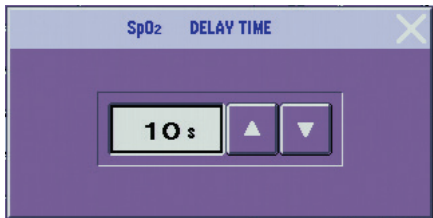

2. Set the time with ▲ or ▼ key.
3. Touch the close button (X) to close the SpO₂ DELAY TIME window.

3. CHANGING SYSTEM SETUP WINDOW SETTINGS

SpO₂ Alarm Escalation

For SpO₂ alarms, two types of alarm escalation are available.

- When the <AFTER ELAPSED TIME> is ON and no action is taken on an alarm for a selected duration, the alarm escalates to the CRISIS level.

Example After elapsed time

SpO₂ alarm level: WARNING
 SpO₂ DELAY TIME: 10 s
 Escalation setting: AFTER ELAPSED TIME: ON, TIME UNTIL ESCALATION: 5 min, PRIORITY: CRISIS (FIXED)

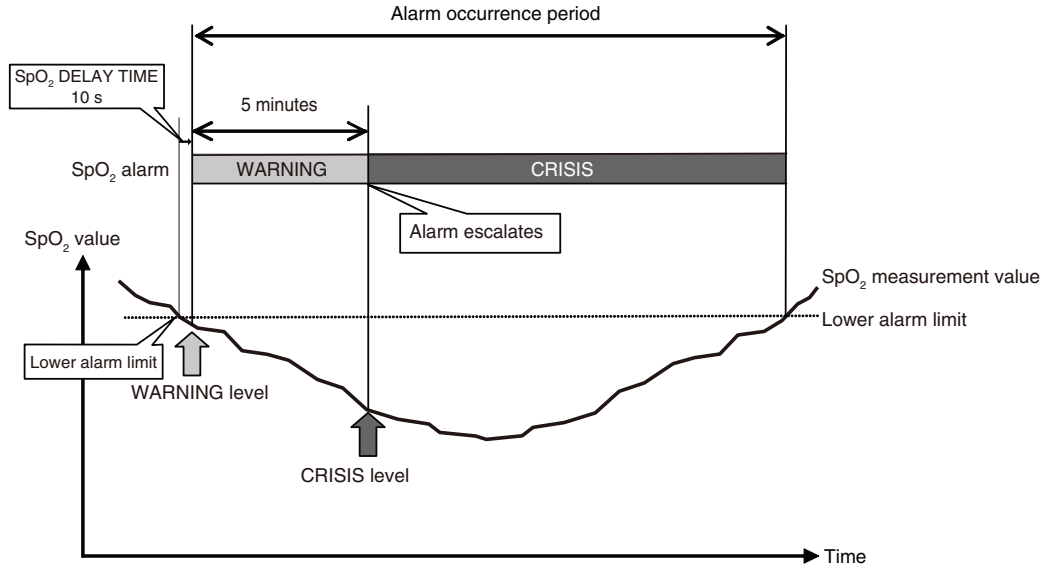

- When the <AFTER VALUE DROP> is ON and the SpO₂ value drops below a set level (3, 5 or 10 below the lower alarm limit) for a selected duration, the alarm escalates to the CRISIS level.

Example 1 After value drop

SpO₂ alarm level: WARNING
 SpO₂ alarm lower limit: 90%SpO₂
 SpO₂ DELAY TIME: 10 s
 Escalation setting: AFTER VALUE DROP: ON, VALUE DROP: -10, DELAY TIME: 20 s, PRIORITY: CRISIS (FIXED)

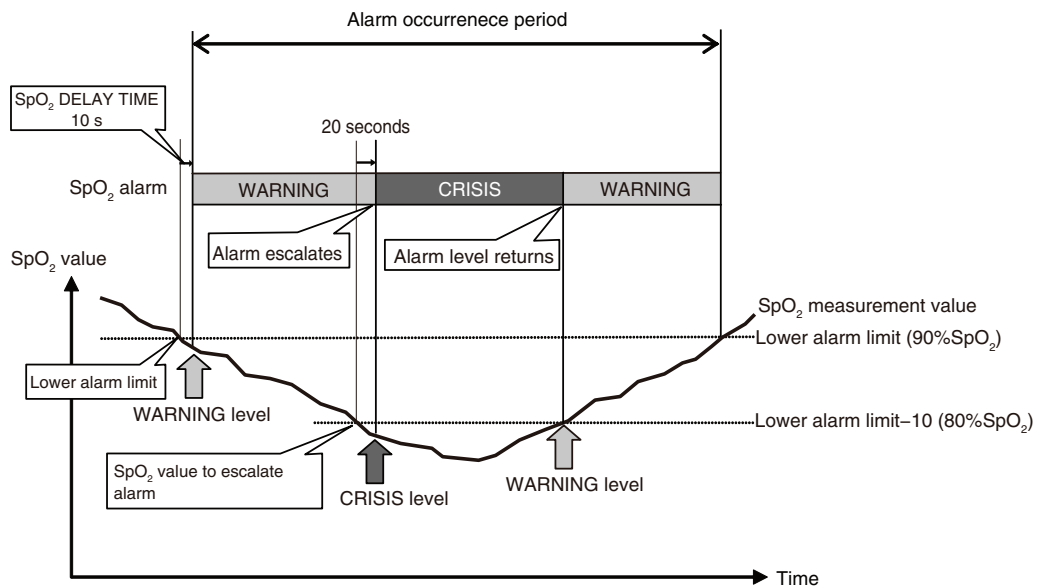

Example 2 After value drop

SpO₂ alarm level: WARNING
 SpO₂ alarm lower limit: 90%SpO₂
 SpO₂ DELAY TIME: 20 s
 Escalation setting: AFTER VALUE DROP: ON, VALUE DROP: -10, DELAY TIME: 5 s,
 PRIORITY: CRISIS (FIXED)

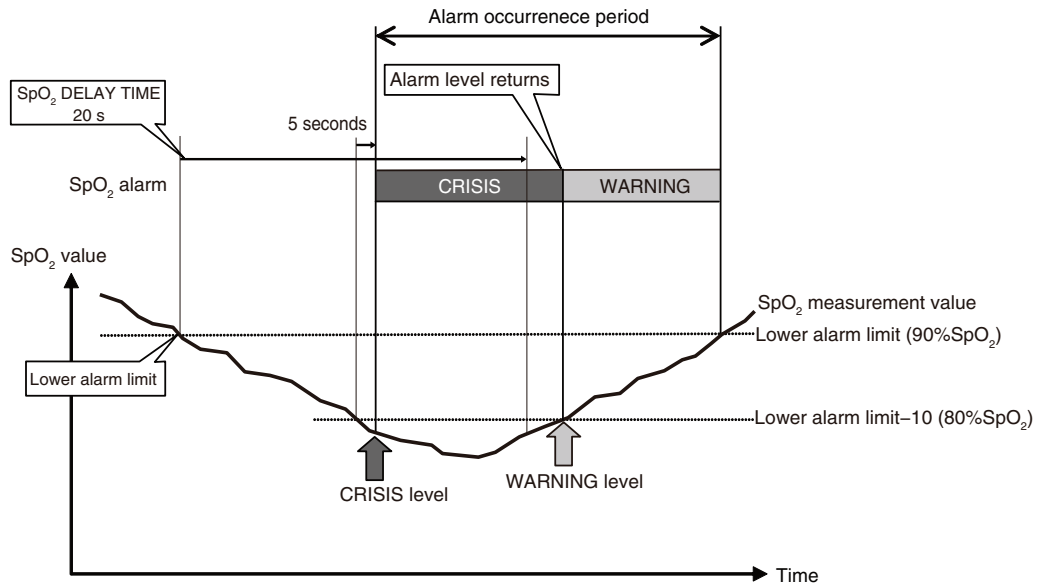

1. Touch the key in the ESCALATION column for SpO₂. The SpO₂ ESCALATION window opens.

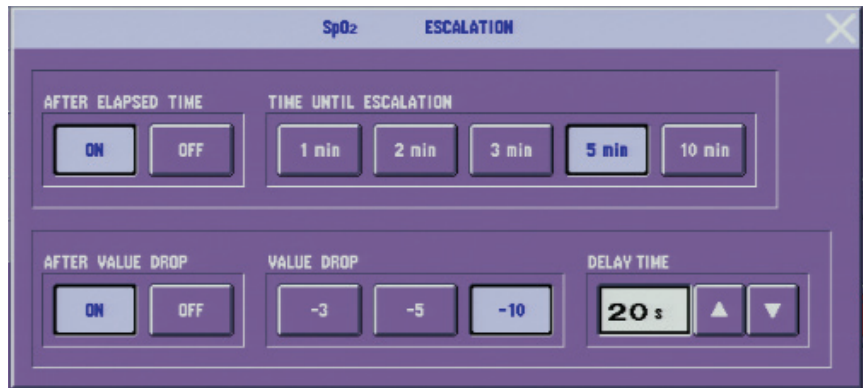

2. Select ON for <AFTER ELAPSED TIME> and/or <AFTER VALUE DROP>. The <TIME UNTIL ESCALATION>, <VALUE DROP> and <DELAY TIME> settings become available.
3. Set the settings for <TIME UNTIL ESCALATION>, <VALUE DROP> and <DELAY TIME>.
4. Touch the close button (X) to close the SpO₂ ESCALATION window.

3. CHANGING SYSTEM SETUP WINDOW SETTINGS

ARRHYTH PRIORITY Page

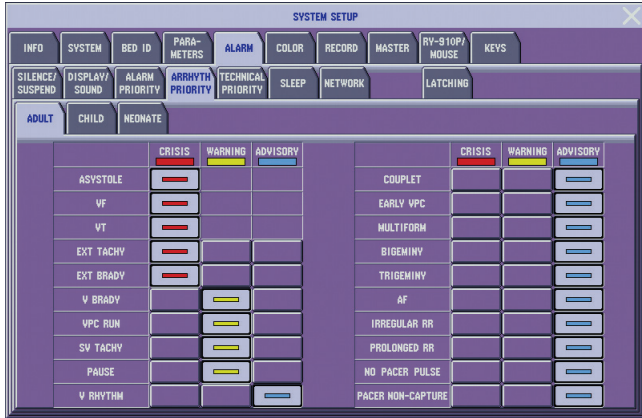

ARRHYTH PRIORITY page when ARRHYTHMIA TYPE is EXTENDED

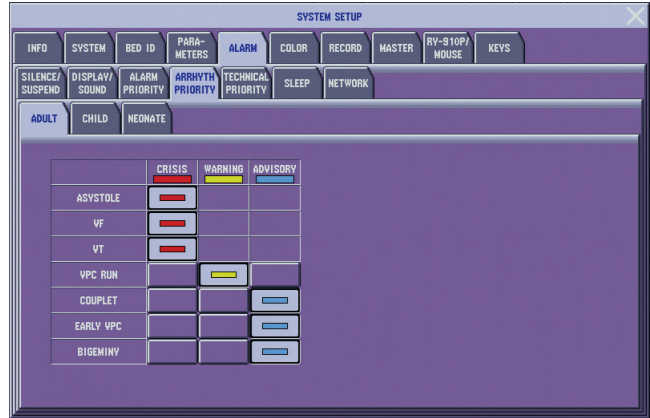

ARRHYTH PRIORITY page when ARRHYTHMIA TYPE is STANDARD

* AF is not available for BSM-6000K series.

Select the alarm level and alarm indicator color for arrhythmia type for each patient type. The color combination depends on the <ALARM PRIORITY COLOR> setting on the DISPLAY/SOUND page.

- CRISIS: The parameter data is highlighted in red with the sound selected in <ALARM SOUND TYPE> and a red blinking lamp.
- WARNING: The parameter data is highlighted in yellow or orange (color selected in <ALARM PRIORITY COLOR>) with the sound selected in <ALARM SOUND TYPE> and a lit yellow lamp.
- ADVISORY: The parameter data is highlighted in cyan or yellow (color selected in <ALARM PRIORITY COLOR>) with the sound selected in <ALARM SOUND TYPE> every 20 or 120 seconds and a lit cyan or yellow lamp. (The sound interval is selected in <ADVISORY PRIORITY ALARM SOUND INTERVAL> and the lamp color is selected in <ALARM PRIORITY COLOR>.)

NOTE

For BSM-6000A series, arrhythmia alarm whose priority is set to CRISIS cannot be set to OFF on the ARRHYTH page of the ARRHYTH ALARMS or ECG window.

TECHNICAL PRIORITY Page



Select the alarm level and alarm indicator color for the three technical alarms for each patient type. The color combination depends on the <ALARM PRIORITY COLOR> setting on the DISPLAY/SOUND page.

WARNING: The parameter data is highlighted in yellow or orange (color selected in <ALARM PRIORITY COLOR>) with the sound selected in <ALARM SOUND TYPE> and a lit yellow lamp.

ADVISORY: The parameter data is highlighted in cyan or yellow (color selected in <ALARM PRIORITY COLOR>) with the sound selected in <ALARM SOUND TYPE> every 20 or 120 seconds and a lit cyan or yellow lamp. (The sound interval is selected in <ADVISORY PRIORITY ALARM SOUND INTERVAL> and the lamp color is selected in <ALARM PRIORITY COLOR>.)

Alarm Escalation

For ECG CHECK ELECTRODES, CANNOT ANALYZE and SpO₂ CHECK PROBE alarms, an alarm escalation is available. When the setting is ON and no action is taken on an alarm for a selected duration, the alarm escalates to the selected level.

Example ECG CHECK ELECTRODES alarm

Alarm level: ADVISORY

Escalation setting: AFTER ELAPSED TIME: ON, TIME UNTIL ESCALATION: 5 min, PRIORITY: WARNING

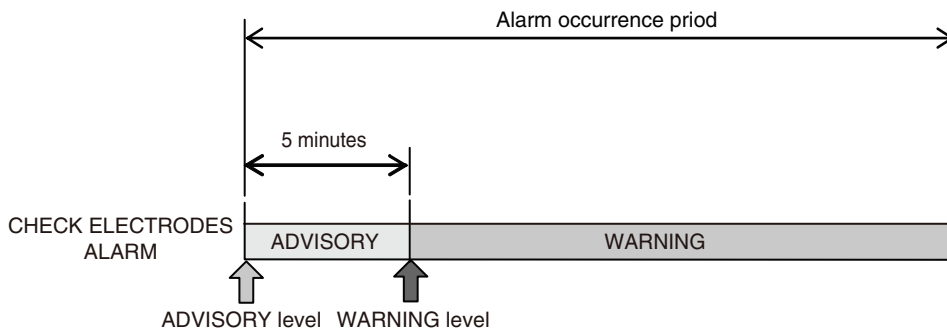

3. CHANGING SYSTEM SETUP WINDOW SETTINGS

1. Touch the key in the ESCALATION column. The ESCALATION window opens.

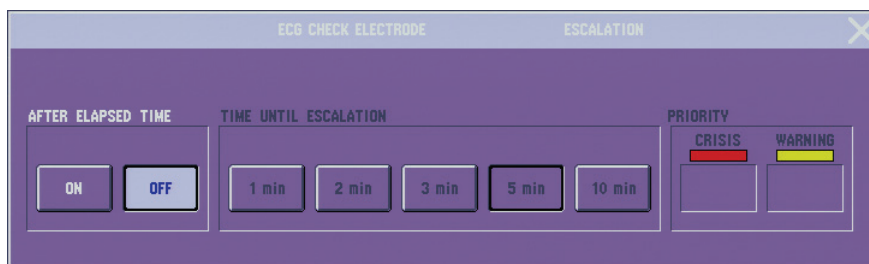

2. Select ON for <AFTER ELAPSED TIME>. The <TIME UNTIL ESCALATION> and <PRIORITY> setting become available.
3. Select <TIME UNTIL ESCALATION> and <PRIORITY>.
4. Touch the close button (X) to close the CHECK ELECTRODE ESCALATION window.

SLEEP Page

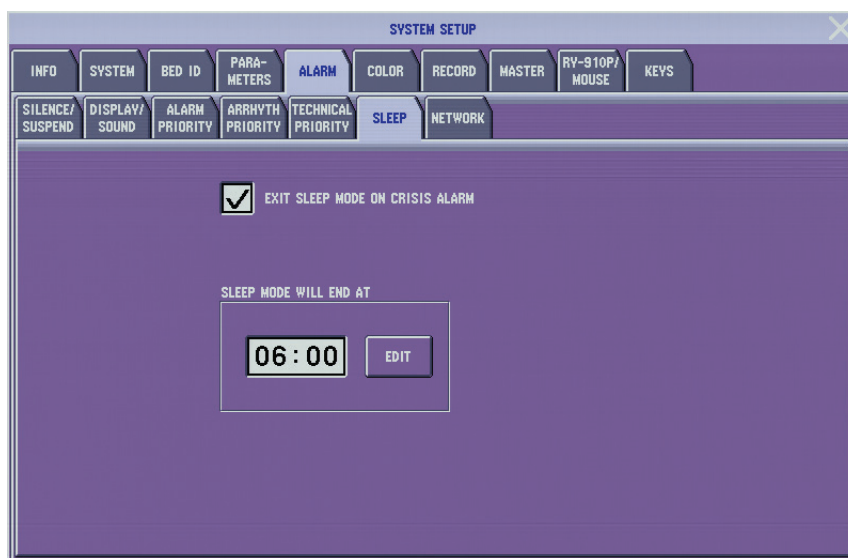

The sleep mode is only available when the ZS-900P* transmitter is connected or the bedside monitor is connected to the central monitor network.

* The ZS-900P transmitter is not available for the BSM-6000A series.

EXIT SLEEP MODE ON CRISIS ALARM: On, Off

WARNING

When using sleep function, monitor the patient on the central monitor or telemetry system. Otherwise, the bedside monitor alarm may be overlooked. When <EXIT SLEEP MODE ON CRISIS ALARM> check box on the ALARM page of the SYSTEM SETUP window is Off, bedside monitor alarms and sync sound appear on the central monitor but do not appear on the bedside monitor during sleep mode.

On: When a crisis alarm occurs during sleep mode, the sleep mode is exited and the home screen appears. When an alarm other than crisis occurs, sleep mode continues.

Off: The sleep mode continues even when a crisis alarm occurs.

SLEEP MODE WILL END AT

Set the clock time to exit sleep mode.

1. Touch the EDIT key in the <SLEEP MODE WILL END AT> box.
2. Enter the clock time with the number keys on the screen.

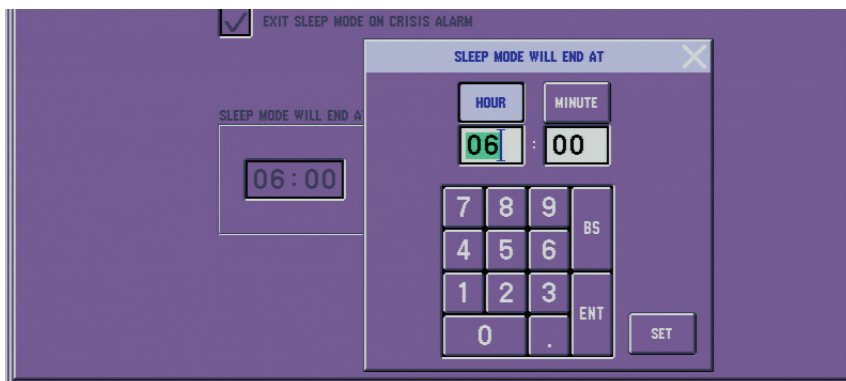

3. Touch the ENT key to register the time.

NETWORK Page

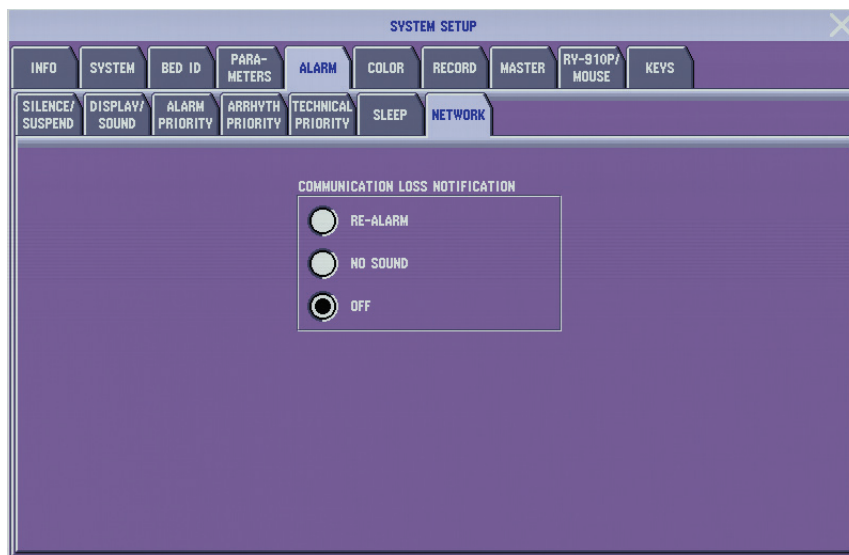

COMMUNICATION LOSS NOTIFICATION: RE-ALARM, NO SOUND, OFF

The “COMMUNICATION LOSS” alarm occurs when the LAN cable of the bedside monitor is disconnected from the bedside monitor or monitor network. When the “COMMUNICATION LOSS” alarm occurs, there is an alarm sound and a screen message. Select from three notification modes for the “COMMUNICATION LOSS” alarm.

3. CHANGING SYSTEM SETUP WINDOW SETTINGS

NOTE

- When <COMMUNICATION LOSS NOTIFICATION> is set to OFF, there is no COMMUNICATION LOSS alarm. When it is set to OFF, always pay careful attention to the communication status.
- When <COMMUNICATION LOSS NOTIFICATION> is set to NO SOUND, an alarm for the same alarm condition does not occur again while communication is still lost. While it is in NO SOUND, always pay careful attention to the communication status.
- When checking the monitoring conditions of the receiving monitors in the network, check it on each receiving monitor.

RE-ALARM: When the Silence Alarms key is pressed, the alarm sounds again at every alarm silence interval (which is set on the SILENCE/SUSPEND page of the SYSTEM SETUP screen) until the alarm condition is resolved. The screen message continues to be displayed.

NO SOUND: When the Silence Alarms key is pressed, there is no sound again. The screen message continues to be displayed.

OFF: No sound or screen message even when the LAN cable is disconnected.

ALARM CAP Page

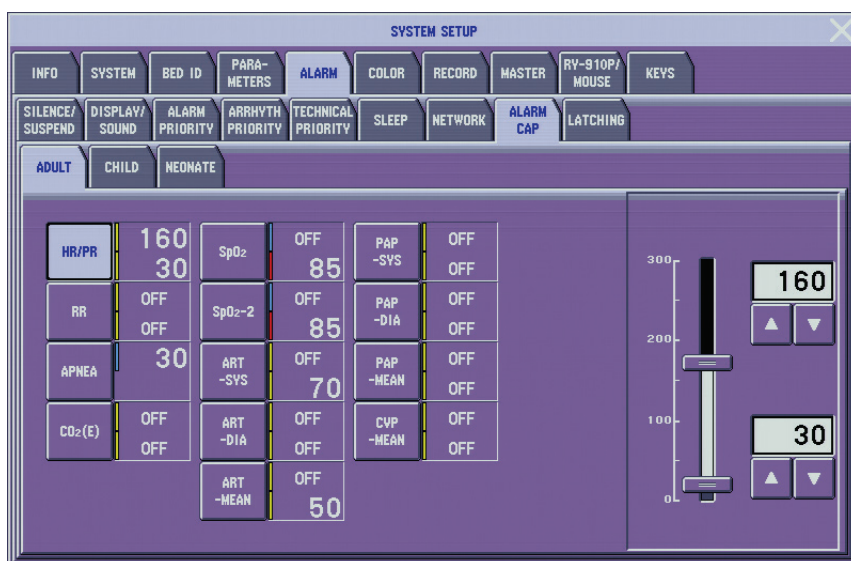

The alarm CAP sets alarm limits for the alarm master and alarm settings for each patient type.



This page is available only when <ALARM CAP> on the SYSTEM CONFIGURATION screen is turned on.

This is only available on BSM-6000A series bedside monitor.

NOTE

- The alarm master for each parameter and the parameter alarm settings are affected by the “ALARM CAP” settings.
- If “EXT TACHY” or “EXT BRADY” are set to ON, the “ALARM CAP” setting for the “HR/PR” cannot be set. To apply the “ALARM CAP” setting for the “HR/PR”, set “EXT TACHY” and “EXT BRADY” to OFF.

3

1. Select the parameter to set alarm limits. The current alarm limits appear in the setting bar area.
2. Touch and drag the sliders to the desired level on the setting bar. Use the  or  key to adjust the setting.

If the upper limit is set to a value above the maximum, the upper limit alarm is set to OFF. If the lower limit is set to a value below the minimum, the lower limit alarm is set to OFF.

LATCHING Page**VITAL AND ARRHYTHMIA ALARM LATCHING**

Alarm latching allows you to require human intervention to end an alarm. If alarm latching is turned on, alarms do not stop automatically when the alarming condition ceases.

When alarm latching is enabled, alarms do not stop until the operator acknowledges the alarm by silencing or suspending alarms on the bedside monitor or central monitor.

The alarm latching function only applies to vital and arrhythmia alarms and it is only available on BSM-6000A series bedside monitors.

Alarm latching can be enabled or disabled separately for crisis, warning and advisory alarm levels.

3. CHANGING SYSTEM SETUP WINDOW SETTINGS

NOTE

Disabling alarm latching for one alarm level also disables alarm latching for the lower level alarms. For example, if you set CRISIS to NONE, the WARNING and ADVISORY are also set to NONE.

Settings

AUDIBLE AND VISUAL (alarm latching ON):

Audible and visual alarms continue until they are acknowledged by the operator.

NONE (alarm latching OFF):

Alarms stop when the alarm trigger condition ends.

COLOR Window

Select the color for each parameter display. To display the parameters in different colors, the <DISPLAY COLOR MODE> on the SYSTEM window must be set to PARAMETER.



1. Touch the parameter key. The COLOR TABLE window appears.
2. Select the desired color for the parameter.

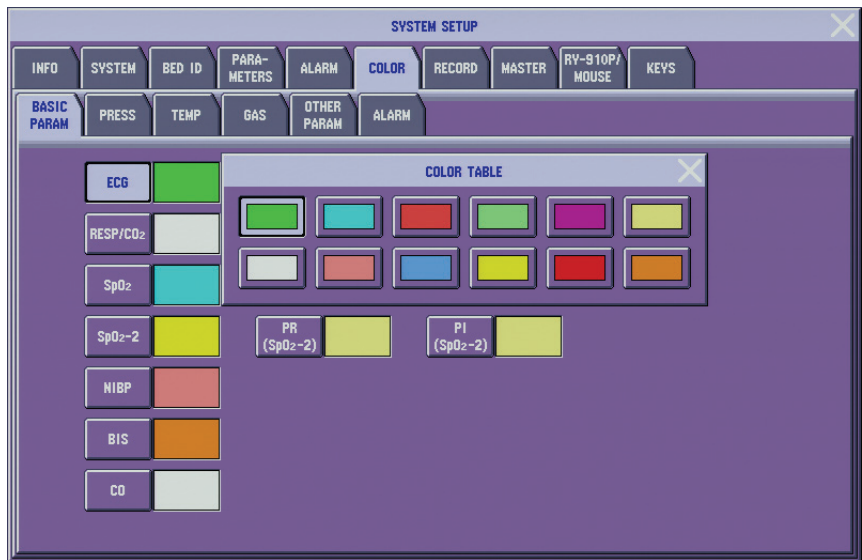

3. Touch the close button (X) to close the COLOR TABLE window.

3. CHANGING SYSTEM SETUP WINDOW SETTINGS

When ALARM is selected for the <DISPLAY COLOR MODE> on the SYSTEM window, all parameters are displayed in the same color. Select the color for all parameter display on the ALARM page.

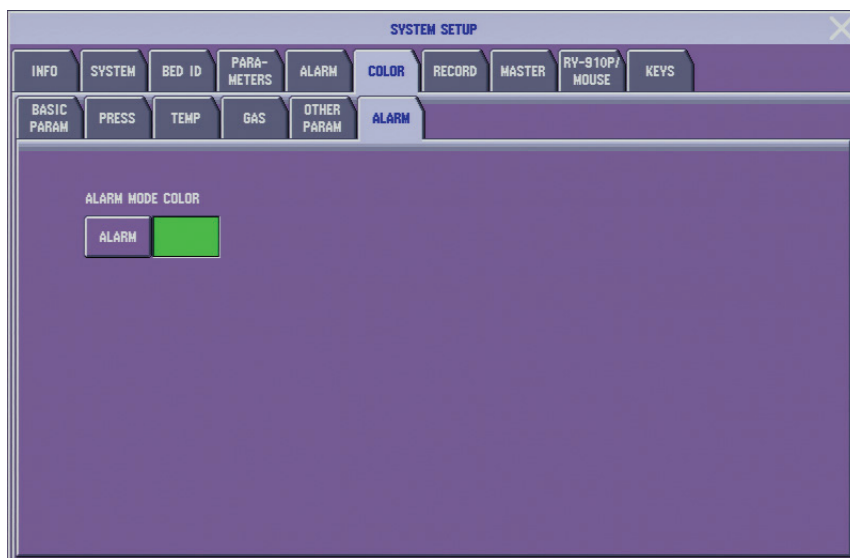

RECORD Window

The RECORD window has two pages.

3

RECORDER Page



MANUAL RECORD: REAL TIME, DELAY

There are two manual recording modes.

REAL TIME: The beginning of the recorded waveform is when the RECORD key on the screen is touched or the [RECORD] key on the front panel is pressed.

DELAY: The beginning of the recorded waveform is 8 seconds before the RECORD key on the screen is touched or 8 seconds before the [RECORD] key on the front panel is pressed.

When manually recording on a central monitor recorder in the central monitor network from monitor with no optional recorder, this setting is fixed at REAL TIME.

MANUAL RECORD TIME: CONTINUOUS, 10 s, 20 s, 30 s

Select the length for manual recording. When CONTINUOUS is selected, the recording starts when the [RECORD] key on the front panel is pressed and stops when the [RECORD] key on the front panel is pressed.

When manually recording on a central monitor recorder in the central monitor network from monitor with no optional recorder, this setting is automatically changed to 30 s when CONTINUOUS is selected.

REVIEW: RECORD PAGE, RECORD ALL

Select the initial recording time when the RECORD key is pressed on the review windows.

RECORD PAGE: The latest period for one page.

RECORD ALL: All the periods in which the data is saved.

3. CHANGING SYSTEM SETUP WINDOW SETTINGS

PERIODIC FREE INTERVAL: 1 to 120 min

You can select the FREE time interval from 1 to 120 min in 1 min steps for periodic recording. See “Setting Periodic Recording” in Operator’s Manual or Section 10 of the User’s Guide Part I.

1. Touch the EDIT key. The PERIODIC FREE INTERVAL window opens.

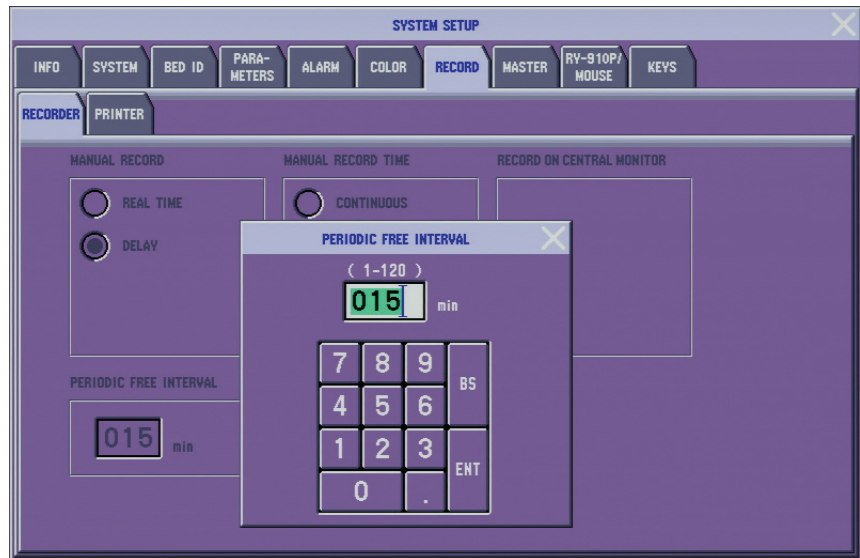

2. Enter the interval by touching the number keys on the screen.
3. Touch the ENT key to register the value.

RECORD ON CENTRAL MONITOR

When the bedside monitor has no optional recorder, recording can be performed on the central monitor recorder in the central monitor network. Select the central monitor for the remote recording destination from the list of central monitors (bed IDs).

FEED PAPER AFTER RECORDING

Select whether or not to feed the recording paper after recording.

PRINTER Page

Change the settings according to the network printer.



PAPER SIZE: A4, LETTER

Select the paper size of the network printer.

12 LEAD ECG PRINT FORMAT: 6 ROWS × 2 COLS, 12 ROWS × 1 COL, 3 ROWS × 4 COLS

Select the 12 lead ECG print format.

IP ADDRESS

Set the IP address of the network printer.

1. Touch the EDIT key beside the <IP ADDRESS> box.
2. Use the number keys on the screen to enter the IP address of the network printer.
3. Touch the SET key to register the IP address.

PRINTER NAME

Enter the printer name. Up to 16 alphanumeric characters can be entered. Normally, use the default setting “lp”. If data cannot be printed, change the setting to the printer name specified in the printer manual. If the printing still cannot be performed, contact your Nihon Kohden representative.

1. Touch the EDIT key beside the <PRINTER NAME> box.
2. Use the alphanumeric keys on the screen to enter the printer name of the network printer.
3. Touch the SET key to register the printer name.

HOSPITAL

You can print the hospital or institution name at the top of the printing paper. Up to 32 alphanumeric characters can be entered.

3. CHANGING SYSTEM SETUP WINDOW SETTINGS

1. Touch the EDIT key beside the <HOSPITAL> box.
2. Use the alphanumeric keys on the screen to enter the hospital name of the network printer.
3. Touch the SET key to register the hospital name.

Using Network Printer

Printer Settings in the Network

Data of a bedside monitor can be printed on a PostScript network printer which supports lpr protocol. The settings and network address on the printer must be set so that PostScript data of the monitor can be printed. The printer must have at least 32 MB memory. For details about the printer, refer to the printer manual or contact your Nihon Kohden representative.

For a network printer, we recommend HP LaserJet 4200N or equivalent.

Settings on the Printer

Set the network address on the printer and other settings so that PostScript data of the monitor can be printed. For the network address, when setting the network address automatically on the monitors, change the settings as shown below.

When setting the network address manually on the monitors, the network address of the printer must be different from the network address of the monitors.

IP address: 010.255.255.250

Subnet mask: 255.000.000.000

Default gateway address: 000.000.000.000

Access control address*: 000.000.000.000

Access control mask*: 000.000.000.000

* HP printers do not have access control address and access control mask settings.

After changing the settings on the printer, turn the printer power off and on so that the IP address is recognized by the printer.

The HP LaserJet 4200N printer automatically recognizes PostScript, so there is no setting for PostScript on this printer. Only the network address (IP ADDRESS, SUBNET MASK and DEF. GATEWAY) needs to be set on this printer.

Settings on the Bedside Monitor

Set the settings on the PRINTER page of the SYSTEM SETUP window on the bedside monitor as follows.

Printer Name*: lp

IP Address: Set the printer's IP address.

* If data cannot be printed when this setting is "lp", change the setting to the printer name specified in the printer manual. If printing still cannot be performed, contact your Nihon Kohden representative.

Printer Setting Example



hp LaserJet 4200 printers

configuration page
1

<h3>Printer Information</h3> <p>Product Name: hp LaserJet 4200 Printer Name: hp LaserJet 4200 Printer Number: 5 Printer Serial Number: SGBX201466 Formatter Number: A4004L9 Firmware Datecode: 20021011 04.003.2 Service ID: 12271 PS Wait Time-out: 300 seconds Page Count: 642 Preventive Maintenance Interval: 200000 Pages Since Last Maintenance: 634</p>	<h3>Memory</h3> <p>Total Memory: 48 MB DWS: 6.00 Automatic Resource Saving Enabled</p>									
<h3>Event Log</h3> <p>Number of Entries in Use: 2 Maximum Number of Entries: 50 Three Most Recent Entries:</p> <table border="1" style="width: 100%; border-collapse: collapse;"> <thead> <tr> <th>Number</th> <th>Page Count</th> <th>Entry</th> </tr> </thead> <tbody> <tr> <td>2</td> <td>153</td> <td>60.02.00</td> </tr> <tr> <td>1</td> <td>156</td> <td>60.02.00</td> </tr> </tbody> </table>	Number	Page Count	Entry	2	153	60.02.00	1	156	60.02.00	<h3>Security</h3> <p>Control Panel Lock: NONE Control Panel Password: DISABLED</p>
Number	Page Count	Entry								
2	153	60.02.00								
1	156	60.02.00								
<h3>Installed Personalities and Options</h3> <p>PS (20010402) PCLXL (20010402) PCL (20010402) DIMM Slot 1: Side 1: 8 MB Flash Side 2: 48 MB SDRAM DIMM Slot 2: Empty DIMM Slot 3: Empty DIMM Slot 4: Empty EIO 1: HP JetDirect J6057A EIO 2: Empty</p>	<h3>Paper Trays and Options</h3> <p>Default Paper Size: A4 Tray 1 Size: ANY SIZE Tray 1 Type: ANY NORMAL Tray 2 Size: A4 STANDARD</p>									



hp LaserJet 4200 printers

EIO 1 - JetDirect Page
1

```

----- HP JetDirect Configuration -----
Status: I/O Card Not Ready
LAN ERROR - LOSS OF CARRIER
Model Number: J6057A
Hardware Address: 0001E6739D02
Firmware Version: R.22.09
Port Config: Disconnected
Auto Negotiation: On
Manufacturing ID: 22014219902201
Date Manufactured: 05/2002

----- Security Settings -----
Admin Password: Not Specified
SSL/TLS: Disabled
Cert Expires: Not Applicable
SNMP Versions: 1;2
SNMP Set Cmty Name: Not Specified
Access List: Not Specified

----- Network Statistics -----
Total Packets Received: 0
Unicast Packets Received: 0
Bad Packets Received: 0
Framing Errors Received: 0
Total Packets Transmitted: 4
Unsendable Packets: 0
Transmit Collisions: 0
Transmit Late Collisions: 0

----- TCP/IP -----
Status: Ready

Host Name: NPI739D02
IP Address: 10.255.255.250
Subnet Mask: 255.0.0.0
Default Gateway: 10.255.255.250
Config By: User Specified
BOOTP/DHCP Server: Not Specified
TFTP Server: Not Specified
Config File: Not Specified
Domain Name: Not Specified
DNS Server: Not Specified
WINS Server: Not Specified
Syslog Server: Not Specified
Idle Timeout: 270 sec
Web JetAdmin URL: Not Specified

----- IPX/SPX -----
Status: Initializing
Primary Frame Type: Auto Select
Network Frame Type: Rcvd

----- Novell/NetWare -----
Status: 16
NOT CONFIGURED
Node Name: NPI739D02
NetWare Mode: Queue Server
NDS Tree Name:
NDS Context:

Attached Server:
SAP Interval: 60 sec

----- AppleTalk -----
Status: Initializing
Name:
Zone: *
Type 1: HP LaserJet
Type 2: LaserWriter
Network Number: 0
Node Number: 0

----- DLC/LLC -----
Status: Initializing
  
```

MASTER Window

For fast and easy alarm setup, a group of alarm items can be set all together at one time. This is called an alarm master. For example, there may be typical alarm settings at your hospital, or you may have certain alarm settings for certain patients.

Even when alarms are set by an alarm master, individual alarm settings in the alarm master can still be changed on the ALARM LIMITS or ARRHYTHM ALARM window or the alarm setting in each parameter setup window.

The alarm returns to this master setting when:

- The monitor power is off for more than 30 minutes and <SHOW ADMIT CONFIRMATION WINDOW> is turned off in the SYSTEM CONFIGURATION screen.
- The patient is admitted or discharged.

WARNING

If more than one medical equipment is used together in the same facility, make sure all equipments have the same alarm default settings (alarm master). If the medical equipments have different alarm default settings and when initialized, the alarm settings differ with the other equipments and alarm cannot be managed appropriately in the facility. If using different alarm default settings according to areas or wings in the facility, manage the alarms appropriately.

PATIENT TYPE Page

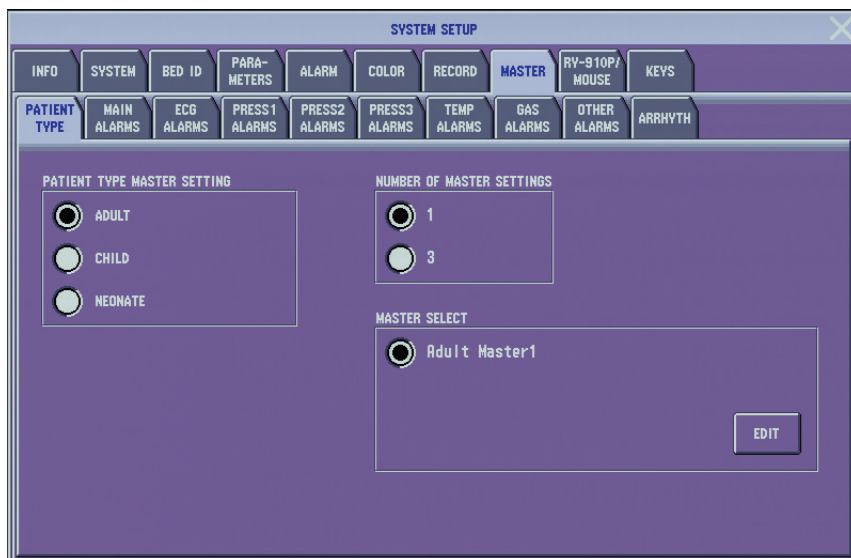

3

PATIENT TYPE MASTER SETTING: ADULT, CHILD, NEONATE

Select the master setting of the PATIENT TYPE. The PATIENT TYPE setting on the ADMIT DISCHARGE window returns to this master setting when:

- The monitor power is off for more than 30 minutes and <SHOW ADMIT CONFIRMATION WINDOW> is turned off in the SYSTEM CONFIGURATION screen.
- The patient is admitted or discharged.

NUMBER OF MASTER SETTINGS: 1, 3

Select the number of alarm masters for each patient type.

MASTER SELECT: Master1, Master2, Master3

If “3” is selected for <NUMBER OF MASTER SETTINGS>, you can select the alarm master. The name of the master can be changed. Refer to the following for details.

Renaming an Alarm Master

The alarm master can be renamed.

1. Select a master to rename.
2. Touch the EDIT key in <MASTER SELECT>.

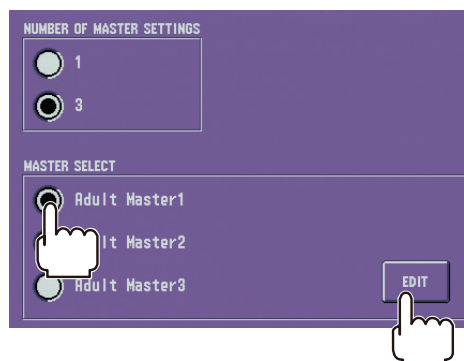

3. CHANGING SYSTEM SETUP WINDOW SETTINGS

3. Type a name with the keyboard. Up to 16 alphanumeric characters can be entered.



4. Touch the OK key to finish editing.

MAIN ALARMS, ECG ALARMS, PRESS ALARMS, TEMP ALARMS, GAS ALARMS, OTHER ALARMS Pages

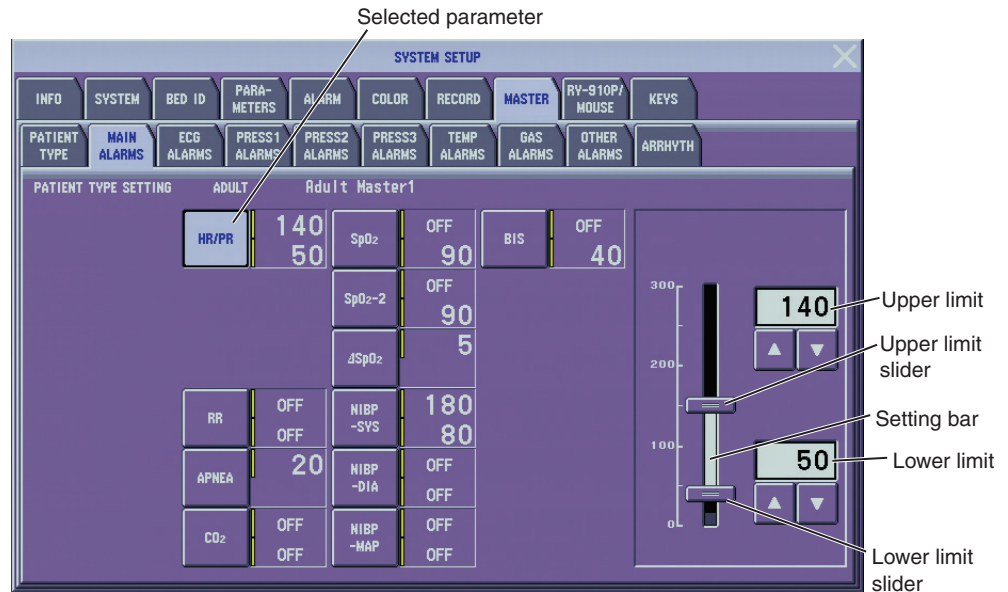

1. Select the parameter to set alarm limits. The current alarm limits appear in the setting bar area.
2. Touch and drag the sliders to the desired level on the setting bar. Use the ▲ or ▼ key to adjust the setting.

If the upper limit is set to a value above the maximum, the upper limit alarm is set to OFF. If the lower limit is set to a value below the minimum, the lower limit alarm is set to OFF.

NOTE

- On BSM-6000A series, if <CRISIS VITAL ALARM MANAGEMENT> on the SYSTEM CONFIGURATION screen is turned on and “ALARM PRIORITY” of the following parameters is set to CRISIS, the alarm setting for that parameter is set to the alarm master setting and the alarm master cannot be set to OFF.

Parameters:

HR/PR UPPER, HR/PR LOWER, RR UPPER, RR LOWER, APNEA, SpO₂ UPPER, SpO₂ LOWER, SpO₂-2 UPPER, SpO₂-2 LOWER, CO₂ (E) UPPER, CO₂ (E) LOWER

- On BSM-6000A series, if <ALARM CAP> on the SYSTEM CONFIGURATION screen is turned on, the alarm master settings and alarm settings of the following parameters are affected by the “ALARM CAP” setting.

Parameters:

HR/PR, RR, APNEA, CO₂, SpO₂, SpO₂-2, ART (SYS/DIA/MEAN), PAP (SYS/DIA/MEAN), CVP (MEAN)

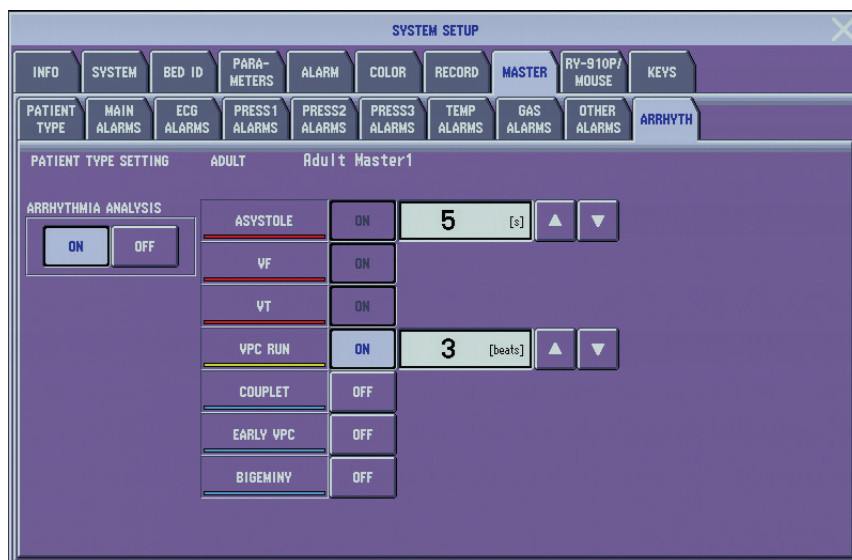
ARRHYTH Page

ARRHYTHM page when ARRHYTHMIA TYPE is STANDARD

ARRHYTHMIA ANALYSIS**WARNING**

For arrhythmia monitoring, set <ARRHYTHMIA ANALYSIS> on the SYSTEM SETUP window to ON. Otherwise, there is no sound or indication for arrhythmia alarms (except for ASYSTOLE).

Select the ARRHYTHMIA ANALYSIS master setting. The arrhythmia analysis can also be turned on or off on the ECG window but the setting changes to this master setting when the monitor is turned off for more than 30 minutes.

3. CHANGING SYSTEM SETUP WINDOW SETTINGS

When the <ARRHYTHMIA ANALYSIS> is set to OFF, an “ARRHYTHMIA ANALYSIS OFF” message is displayed on the screen.

When the site setting is NICU on the SITE window of the SYSTEM CONFIGURATION screen and <ARRHYTHMIA ANALYSIS> on the SYSTEM SETUP window is set to OFF, ST level and VPC rate are not displayed on the home screen.

Arrhythmia Alarms

When “EXTENDED” is selected for the <ARRHYTHMIA TYPE> on the ECG page of the PARAMETERS window in the SYSTEM SETUP window, there are two pages for arrhythmia alarms master settings.

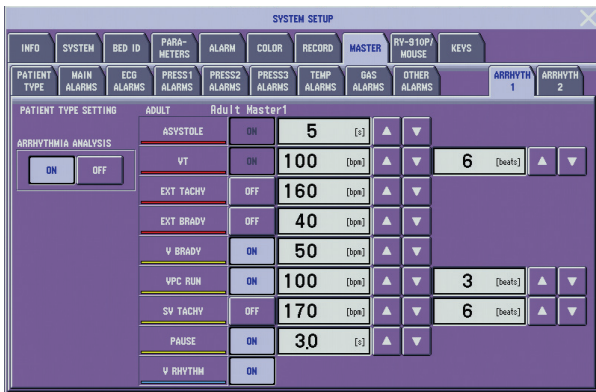

ARRHYTH 1 page when ARRHYTHMIA TYPE is EXTENDED



ARRHYTH 2 page when ARRHYTHMIA TYPE is EXTENDED

* AF is not available for BSM-6000K series.

To turn each arrhythmia alarm ON/OFF

Touch the ON or OFF key for each arrhythmia type to set it on or off. ASYSTOLE, VF, VT are fixed to ON.

To set the threshold

Use the ▲ or ▼ key to change setting.

NOTE

When the “EXT TACHY” or “EXT BRADY” alarm is set to OFF, the heart rate limit range is 15 to 300 beat/min or OFF.

RY-910P/MOUSE Window

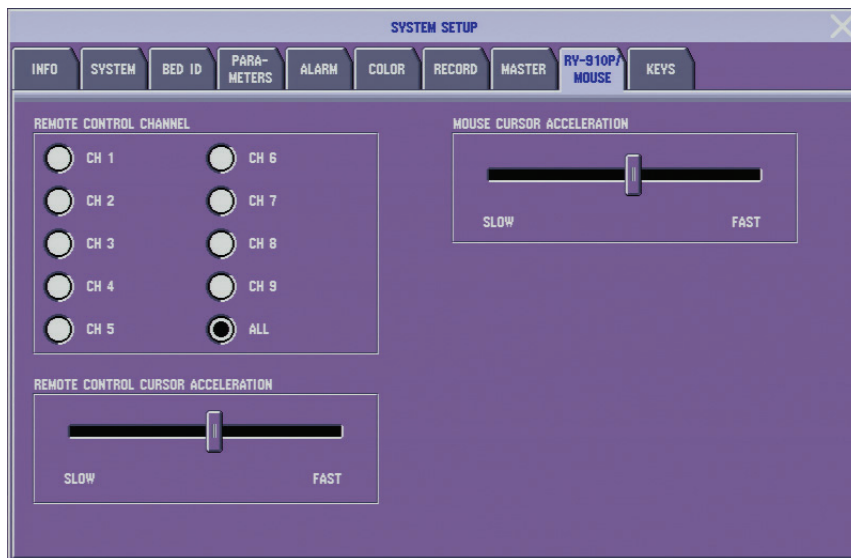

3

REMOTE CONTROL CHANNEL

CAUTION

- Set the remote control channel on the monitor to prevent the remote control from operating a different monitor.
- When several monitors are installed close together, check that the remote control operates only the desired monitor. If the remote control operates a different monitor, recheck the channel setting.

Set the channel for the remote control.

REMOTE CONTROL CURSOR ACCELERATION

Set the distance moved by the remote control cursor.

MOUSE CURSOR ACCELERATION

Set the distance moved by the mouse cursor.

3. CHANGING SYSTEM SETUP WINDOW SETTINGS

KEYS Window

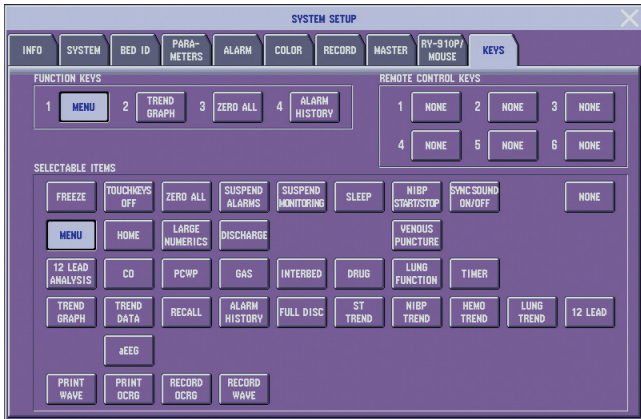

KEYS window when site is ICU

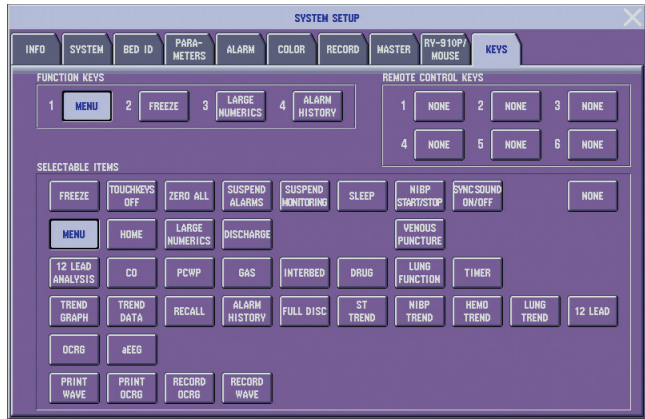

KEYS window when site is NICU

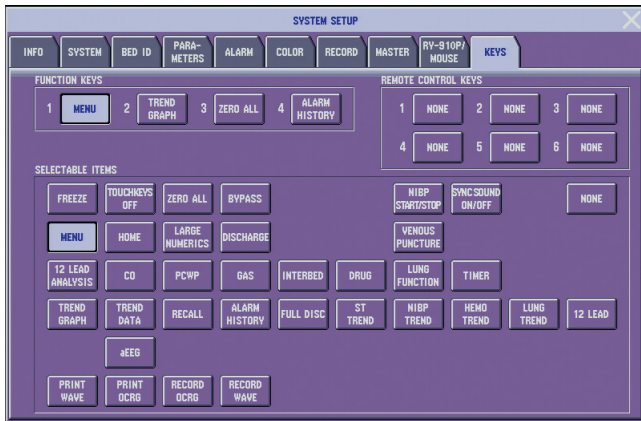

KEYS window when site is OR

FUNCTION KEYS

A function or window can be assigned to each function key on the upper left corner of the screen so you can easily access frequently used windows or functions. When a function or window is assigned to a function key, that function can be performed or that window can be displayed just by touching the function key. You do not need to return to the home screen or display the MENU window.

There are four function keys on the monitor. Assign a function or window to each key from the <SELECTABLE ITEMS> box.

REMOTE CONTROL KEYS

There are six function keys on the remote control. Assign a function or window to each key from the <SELECTABLE ITEMS> box.

Function keys

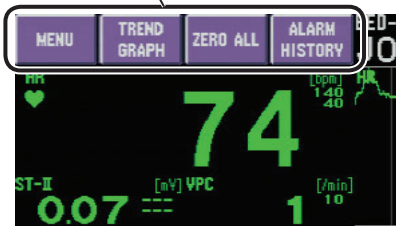

Section 4 Reference

Factory Default Settings	4.2
SYSTEM CONFIGURATION Screen	4.3
SYSTEM SETUP Window	4.5
General Requirements for Connecting Medical Electrical Systems	4.22
Connector Pin Assignment	4.23
MU-631R/MU-651R/MU-671R Main Unit	4.23
QI-631P Interface	4.23
QI-632P Interface	4.24
QI-634P Interface	4.24
QI-671P Interface	4.25
QI-672P Interface	4.26
AY-631P/AY-633P/AY-651P/AY-653P/AY-661P/AY-663P/AY-671P/AY-673P Input Unit and BSM-1700 series Bedside Monitor	4.26
Check Sheet for Unit Settings.....	4.27

Factory Default Settings

This section shows the factory default settings of the SYSTEM CONFIGURATION screen and SYSTEM SETUP window settings. Other default settings are listed in the Operator's Manual. OK in the backup column indicates that the settings remain in memory even when the power is turned off.

NOTE

- When the settings are initialized, the site mode is changed to ICU and all settings, except for the settings on the NETWORK window and CHANGE PASSWORD window of the SYSTEM CONFIGURATION screen, are changed to the factory default settings for the ICU mode.
- Changing the site mode does not initialize the settings.
- Changing the site mode changes the settings to the settings of the new mode. e.g. When the site mode is changed from ICU to NICU, HR/PR upper limit setting on the MAIN ALARMS page of the MASTER window changes from 140 to 200 beats/min.

SYSTEM CONFIGURATION Screen

Window	Page	Setting Item	Setting Range	Default Setting	Backup	
SITE			OR, ICU, NICU	ICU		
			12 LEAD ANALYSIS (NICU site only)* ¹	On, Off On		
NETWORK	IP ADDRESS/ PROTOCOL	IP ADDRESS SETUP	AUTO, MANUAL	AUTO	OK	
		PROTOCOL	LS-NET, HL7	LS-NET		
	LS-NET	GROUP	General, CCU, CCU-1, CCU-2, ER, ICU, ICU-1, ICU-2, OR, PostCCU, Recovery, Tele-1, Tele-2, Tele-3 Tele-4, Tele-5	General		
		PROTOCOL* ¹	1ST GEN, 2ND GEN	1ST GEN		
	ORU		USE ORU	On, Off		Off
			ORU PORT No.	1024 to 65535		7998
			ORU SAMPLING	1 min, 5 min, 10 min, 30 min, 1 h		1 min
	ORF		USE ORF	On, Off		Off
			ORF PORT No.	1024 to 65535		9004
	QRY		USE QRY	On, Off		Off
			HIS SERVER IP ADDRESS	-		000.000.000.000
			HIS SERVER PORT No.	1024 to 65535		7997
	ADT		USE ADT	On, Off		Off
			ADT MONITORING PORT No.	1024 to 65535		9005
			ADT PATIENT INFO PORT No.	1024 to 65535		9006
			PATIENT LIST PORT No.	1024 to 65535		9007
	MSH SEGMENT		HL7 VERSION	-		-
			CHARACTER SET	-		-
			SENDING APPLICATION	Up to 32 characters		NIHON KOHDEN
			SENDING FACILITY	Up to 32 characters		NIHON KOHDEN
			RECEIVING APPLICATION	Up to 32 characters		CLIENT APP
			RECEIVING FACILITY	Up to 32 characters		CLIENT FACILITY
	UNITS		HEIGHT	cm, inch		cm
WEIGHT			kg, pound	kg		
ST			mV, mm	mV		
TEMPERATURE			°C, °F	°C		
HEMOGLOBIN			g/dL, mmol/L	g/dL		
BLOOD PRESSURE			BSM-6000A series: mmHg/cmH ₂ O, kPa/hPa BSM-6000K series: mmHg, kPa	BSM-6000A series: mmHg/cmH ₂ O BSM-6000K series: mmHg		
CO ₂ * ²			mmHg, kPa	mmHg		
RESPIRATION* ²			cmH ₂ O, hPa	cmH ₂ O		
		tcPO ₂ /PCO ₂ * ²	mmHg, kPa	mmHg		

4

OK

4. REFERENCE

Window	Page	Setting Item	Setting Range	Default Setting	Backup
DATA MANAGEMENT		DATA TRANSPORT USING INPUT UNIT	ENABLE, DISABLE	DISABLE	OK
		USE SETTINGS IN INPUT UNIT	On, Off	On	
		TIME ZONE	0 to ±12:00 in 30 minute steps	+9:00	
		SHOW ADMIT CONFIRMATION WINDOW	On, Off	Off	
		ADMIT MODE	AUTO, MANUAL	BSM-6000A series: MANUAL BSM-6000K series: AUTO	
		STANDBY MODE	On, Off	Off	
PC		BAUD RATE	9600, 19200, 38400	9600	
		PARITY	NONE, EVEN, ODD	NONE	
		WORD LENGTH	7 bits, 8 bits	8 bits	
		STOP BIT	1, 2	1	
CHANGE PASSWORD			4 numbers	1234	
OTHER		ZS-900P TYPE	TYPE 8, TYPE A	TYPE A	
		HT PULSE OUTPUT	POSITIVE, NEGATIVE	NEGATIVE	
		TIME ZONE	0 to ±12:00 in 30 minute steps	+9:00	
		ALARM CAP* ¹	On, Off	Off	
		CRISIS VITAL ALARM MANAGEMENT* ¹	On, Off	Off	
		SIMULATION MODE	On, Off	Off	
		DATE FORMAT	YYYY-MM-DD, DD-MM-YYYY, MM-DD-YYYY	BSM-6000A series: MM-DD-YYYY BSM-6000K series: DD-MM-YYYY	
		TIME FORMAT	HH:MM, HH:MM:SS	HH:MM	

*¹ Not available for BSM-6000K series.

*² Not available for BSM-6000A series.

SYSTEM SETUP Window

Window	Page	Setting Item	Setting Range	Default Setting	Backup
SYSTEM	DISPLAY	WAVE DISPLAY	MOVING, FIXED	MOVING	OK
		DISPLAY COLOR MODE	PARAMETER, ALARM	PARAMETER	
		SUB DISPLAY	SLAVE, HOME SCREEN	SLAVE	
		CURRENT TREND	NORMAL, OCRG 1 cm/min, OCRG 3 cm/min, OFF	NORMAL	
		POWER SAVING MODE	On, Off	On	
		FILL IN CO ₂ WAVEFORM	On, Off	Off	
		CASCADE DISPLAY	On, Off	Off	
		ECG WAVEFORM AT TOP OF SCREEN OVERLAPS WINDOW	On, Off	Off	
	LAYOUT	NUMERIC PARAMETER AREA	SIDE, SIDE + SMALL BOTTOM, SIDE + LARGE BOTTOM	SIDE	
		LARGE NUMERIC SCREEN LAYOUT	2 × 2, 3 × 4	2 × 2	
		NUMERIC PARAMETER AREA (SIDE)	LEFT, RIGHT	LEFT	
		NIBP NUMERIC AREA	BOTTOM, SIDE	BOTTOM	
		BELOW PRESS	On, Off	Off	
		PRESS COMMON SCALE AREA	NORMAL, LARGE	NORMAL	
	VOLUME	ALARM MINIMUM VOLUME	7 levels	1	
		NIBP COMPLETION	7 levels	2	
		KEY CLICK	7 levels	2	
		INTERBED ALARM	7 levels	2	
	INTERBED	INTERBED ALARMS TO DISPLAY	ALL, CRISIS AND WARNING, CRISIS, NONE	NONE	
	BED ID			Up to 10 alphanumeric	
PARAMETERS	ECG	ECG ELECTRODES	IEC, AHA	IEC	
		SYNC SOUND PITCH	HIGH, MIDDLE, LOW	HIGH	
		HUM FILTER	50 Hz, 60 Hz	50 Hz	
		ARRHYTHMIA TYPE	STANDARD, EXTENDED	STANDARD	
		AF DETECTION*	On, Off	Off	
		PACING MARK POSITION	ABOVE WAVE, OVERLAP WAVE	ABOVE WAVE	
		ALARM INDICATOR QRS SYNC	On, Off	OR, NICU: Off ICU: On	
		NEONATE ST MEASUREMENT	On, Off	On	
	NIBP	NIBP INTERVAL KEY STARTS NIBP	On, Off	Off	
		SIM	On, Off	OR: On	
		COMPLETION SOUND	OFF, NK1, NK2	OR: NK2 ICU, NICU: OFF	
		START TIME	CLOCK, PERIOD	CLOCK	
		NIBP-PR DISPLAY	On, Off	Off	
		INTERVAL MASTER	MANUAL, STAT, SIM, 1 min, 2 min, 2.5 min, 5 min, 10 min, 15 min, 30 min, 1 h, 2 h, 4 h, 8 h	MANUAL	
		OLD DATA DISPLAY	DIM, HIDE	DIM	
		TIME UNTIL DATA IS OLD	5 min, 10 min, 30 min, 1 h, 24 h	OR: 10 min ICU, NICU: 30 min	

* Not available for BSM-6000K series.

4. REFERENCE

Window	Page	Setting Item	Setting Range	Default Setting	Backup	
PARAMETERS	NIBP MODE	STAT	STAGE 1 INTERVAL	STAT, 1 min	STAT	OK
			STAGE 1 OPERATING TIME	5 min, 10 min	5 min	
			STAGE 2 INTERVAL	MANUAL, 1 min, 2 min, 2.5 min, 5 min, 10 min, 15 min, 30 min	OR: 5 min ICU, NICU: MANUAL	
		SIM (OR site only)	STAGE 1 INTERVAL	1 min, 2 min, 2.5 min	2 min	
			STAGE 1 OPERATING TIME	5 min, 10 min, 15 min	15 min	
			STAGE 2 INTERVAL	2 min, 2.5 min, 5 min	5 min	
		INTERVAL	NIBP INTERVALS	OFF, MANUAL, STAT, SIM, 1 min, 2 min, 2.5 min, 5 min, 10 min, 15 min, 30 min, 1 h, 2 h, 4 h, 8 h	OR: OFF, MANUAL, STAT, 2 min, 2.5 min, 5 min, 10 min ICU: OFF, MANUAL, 5 min, 10 min, 30 min, 1 h NICU: OFF, MANUAL, 30 min, 1 h	
		VENOUS PUNCTURE	VENOUS PUNCTURE	On, Off	Off	
			TARGET CUFF PRESSURE	ADULT: 20 to 120 mmHg CHILD: 20 to 80 mmHg NEONATE: 20 to 50 mmHg	ADULT: 70 mmHg CHILD: 50 mmHg NEONATE: 40 mmHg	
		INITIAL CUFF PRESS	INITIAL CUFF PRESSURE	ADULT: 100 to 280 mmHg CHILD: 100 to 280 mmHg NEONATE: 70 to 145 mmHg	ADULT: 180 mmHg CHILD: 140 mmHg NEONATE: 100 mmHg	
		CO ₂	GAS COMPOSITION	CO ₂ : 4.00 to 6.00% (0.1 step)	5.00	
		GAS	MAINTENANCE	GAS COMPOSITION	CO ₂ : 1.50 to 57.00% (0.01 step) O ₂ : 0 to 55.50% (0.01 step) N ₂ O: 1.50 to 92% (0.01 step) Agent: 1.50 to 18.50% (0.01 step)	
	CALIBRATION GAS			HAL, ISO, ENF, SEV, DES	ISO	
	SETTINGS		AGENT HOLD TIME	10 to 60 min	60	
			MAX Ttot	20 to 40 s	30	
			TEMPERATURE AND HUMIDITY COMPENSATION	ATPD, STPD, BTPS	ATPD	
	MAC*		UNCORRECTED, AMBIENT PRESSURE CORRECTED, ENHANCED	UNCORRECTED		
	FLOW/Paw*	SETTINGS	GAS SAMPLING CORRECTION	AUTO, OFF	AUTO	

* Not available for BSM-6000A series.

Window	Page	Setting Item	Setting Range	Default Setting	Backup
PARAMETERS	EEG	AUTO IMPEDANCE CHECK	ON, OFF	ON	OK
		BAND SETTINGS	0.0 to 60.0 Hz	1.0 < DELTA < 4.0 < THETA < 8.0 < ALPHA < 13.0 < BETA < 30.0 < GAMMA <50.0	
	OTHER PARAM	PRESS FILTER	12 Hz, 20 Hz	12 Hz	
		IBP ANALOG OUT	FIXED POSITION, HIGHEST PRIORITY LABEL	HIGHEST PRIORITY LABEL	
		SpO ₂ SYNC SOUND TONE	81-100, 40-100	81-100	
		“CHECK Ti TEMP” MESSAGE*1	On, Off	On	
NOISE REDUCTION ON IMPEDANCE RESP	On, Off	On			
BREATHS FOR NEONATE IMPEDANCE RESP CALCULATION	8, 16	8			
ALARM	SILENCE/SUSPEND	SILENCE ALARMS TIME	1 min, 2 min, 3 min	2 min	
		ALARM ACTIVATION DELAY	AUTO, 1 min, 2 min, 3 min	2 min	
		SILENCE SpO ₂ ALARM*2	On, Off	Off	
		ALARM INACTIVATION	SUSPEND ALARMS, ALL ALARMS OFF	ICU, NICU: SUSPEND ALARMS OR: ALL ALARMS OFF	
			SUSPEND ALARMS TIME: 1 min, 2 min, 3 min	OR: — ICU, NICU: 2 min	
			ALARMS OFF TYPE*3: BYPASS, ALL ALARMS OFF	OR: BYPASS ICU, NICU: —	
		REMINDER*4: On, Off	Off		
	ALARM INDICATOR LIT: On, Off	ICU, NICU: On OR: Off			
	DISPLAY/SOUND	LIMIT DISPLAY	MARK BRIGHT, MARK DIM, VALUES	VALUES	
		ALARM SOUND TYPE	NK1, NK2, IEC	NK1	
		ALARM PRIORITY COLOR	• CRISIS: red, WARNING: yellow, ADVISORY: cyan • CRISIS: red, WARNING: orange, ADVISORY: yellow	CRISIS: red, WARNING: yellow, ADVISORY: cyan	
		ADVISORY ALARM SOUND INTERVAL	20 s, 120 s	20 s	
AVAILABLE ALARM TYPES		MAIN, ALL	MAIN		

*1 Not available for BSM-6000A series.

*2 Not available for BSM-6000K series.

*3 Available only when site is OR.

*4 Available only when ALARMS OFF TYPE is set to ALL ALARMS OFF.

4. REFERENCE

Window	Page		Setting Item	Setting Range	Default Setting	Backup			
ALARM	ALARM PRIORITY	ADULT, CHILD, NEONATE	PARAMETER 1			OK			
			HR/PR UPPER		CRISIS, WARNING, ADVISORY		WARNING		
			HR/PR LOWER		CRISIS, WARNING, ADVISORY		ADULT, CHILD: WARNING NEONATE: CRISIS		
			HR/PR DELAY TIME		0 to 10 s		0 s		
			VPC		CRISIS, WARNING, ADVISORY		ADVISORY		
			ST		CRISIS, WARNING, ADVISORY		WARNING		
			RR UPPER		CRISIS, WARNING, ADVISORY		WARNING		
			RR LOWER		CRISIS, WARNING, ADVISORY		WARNING		
			RR DELAY TIME		0 to 30 s		5 s		
			APNEA		PRIORITY		CRISIS, WARNING, ADVISORY	ADULT, CHILD: WARNING NEONATE: CRISIS	
					ESCALATION		AFTER ELAPSED TIME	ON, OFF	OFF
							TIME UNTIL ESCALATION	20 s, 30 s, 40 s, 50 s, 60 s	40 s
							PRIORITY	CRISIS, WARNING	CRISIS
			SpO ₂ UPPER		CRISIS, WARNING, ADVISORY		WARNING		
			SpO ₂ UPPER/ LOWER		DELAY TIME		0 to 30 s	10 s	
			SpO ₂ LOWER		PRIORITY		CRISIS, WARNING	ADULT, CHILD: WARNING NEONATE: CRISIS	
					ESCALATION		AFTER ELAPSED TIME	ON, OFF	OFF
							TIME UNTIL ESCALATION	1 min, 2 min, 3 min, 5 min, 10 min	5 min
							AFTER VALUE DROP	ON, OFF	OFF
							VALUE DROP	-3, -5, -10	-10
							DELAY TIME	0 to 30 s	20 s
			ΔSpO ₂		CRISIS, WARNING, ADVISORY		WARNING		
			PARAMETER 2						
			NIBP		CRISIS, WARNING, ADVISORY		WARNING		
			PRESS		CRISIS, WARNING, ADVISORY		WARNING		
			TEMP		CRISIS, WARNING, ADVISORY		ADVISORY		
			CO ₂ (E) UPPER		CRISIS, WARNING		WARNING		
			CO ₂ (E) LOWER		CRISIS, WARNING		WARNING		
			CO ₂ (I)		CRISIS, WARNING		WARNING		
			O ₂ (E)		CRISIS, WARNING, ADVISORY		ADVISORY		
			O ₂ (I)		CRISIS, WARNING		WARNING		
			N ₂ O(E)		CRISIS, WARNING, ADVISORY		ADVISORY		
			N ₂ O(I)		CRISIS, WARNING		WARNING		
			AGENT(E)		CRISIS, WARNING, ADVISORY		ADVISORY		
			AGENT(I)		CRISIS, WARNING		WARNING		
			BIS		CRISIS, WARNING, ADVISORY		WARNING		
			EXTERNAL		CRISIS, WARNING, ADVISORY		ADVISORY		

Window	Page			Setting Item	Setting Range	Default Setting	Backup
ALARM	ALARM PRIORITY	ADULT, CHILD, NEONATE	PARAMETER 3	MV* ¹	CRISIS, WARNING, ADVISORY	ADVISORY	OK
				Ppeak* ¹	CRISIS, WARNING, ADVISORY	ADVISORY	
				PEEP* ¹	CRISIS, WARNING, ADVISORY	ADVISORY	
				SEF	CRISIS, WARNING, ADVISORY	ADVISORY	
				TP	CRISIS, WARNING, ADVISORY	ADVISORY	
				CCO/CCI* ¹	CRISIS, WARNING, ADVISORY	ADVISORY	
	ARRHYTHM PRIORITY* ²	ADULT, CHILD, NEONATE	ASYSTOLE	CRISIS fixed	CRISIS		
			VF	CRISIS fixed	CRISIS		
			VT	CRISIS fixed	CRISIS		
			EXT TACHY* ³	CRISIS, WARNING, ADVISORY	CRISIS		
			EXT BRADY* ³	CRISIS, WARNING, ADVISORY	CRISIS		
			V BRADY* ³	CRISIS, WARNING, ADVISORY	WARNING		
			VPC RUN	CRISIS, WARNING, ADVISORY	WARNING		
			SV TACHY* ³	CRISIS, WARNING, ADVISORY	WARNING		
			PAUSE* ³	CRISIS, WARNING, ADVISORY	WARNING		
			V RHYTHM* ³	CRISIS, WARNING, ADVISORY	ADVISORY		
			COUPLET	CRISIS, WARNING, ADVISORY	ADVISORY		
			EARLY VPC	CRISIS, WARNING, ADVISORY	ADVISORY		
			MULTIFORM* ³	CRISIS, WARNING, ADVISORY	ADVISORY		
			BIGEMINY	CRISIS, WARNING, ADVISORY	ADVISORY		
			TRIGEMINY* ³	CRISIS, WARNING, ADVISORY	ADVISORY		
			AF* ⁴	CRISIS, WARNING, ADVISORY	ADVISORY		
			IRREGULAR RR* ³	CRISIS, WARNING, ADVISORY	ADVISORY		
			PROLONGED RR* ³	CRISIS, WARNING, ADVISORY	ADVISORY		
	NO PACER PULSE* ³	CRISIS, WARNING, ADVISORY	ADVISORY				
	PACER NON-CAPTURE* ³	CRISIS, WARNING, ADVISORY	ADVISORY				
	TECHNICAL PRIORITY	ADULT, CHILD, NEONATE	ECG CHECK ELECTRODE	Alarm level	WARNING, ADVISORY	ADVISORY	
				AFTER ELAPSED TIME	ON, OFF	OFF	
				TIME UNTIL ESCALATION	1 min, 2 min, 3 min, 5 min, 10 min	5 min	
				PRIORITY	CRISIS, WARNING	WARNING	
			CANNOT ANALYZE	Alarm level	WARNING, ADVISORY	WARNING	
				AFTER ELAPSED TIME	ON, OFF	OFF	
				TIME UNTIL ESCALATION	1 min, 2 min, 3 min, 5 min, 10 min	5 min	
PRIORITY				CRISIS, WARNING	CRISIS		
SpO ₂ CHECK PROBE			Alarm level	WARNING, ADVISORY	ADVISORY		
			AFTER ELAPSED TIME	ON, OFF	OFF		
			TIME UNTIL ESCALATION	1 min, 2 min, 3 min, 5 min, 10 min	5 min		
			PRIORITY	CRISIS, WARNING	WARNING		

*¹ Not available for BSM-6000A series.

*² For BSM-6000A series, when the arrhythmia priority is set to crisis level, the arrhythmia alarm cannot be set to OFF on the ARRHYTHM page of the ARRHYTHM ALARMS or ECG window.

*³ Available only when <ARRHYTHMIA TYPE> on the ECG page of the SYSTEM SETUP window is set to EXTENDED.

*⁴ Not available for BSM-6000K series. Available only when <ARRHYTHMIA TYPE> on the ECG page of the SYSTEM SETUP window is set to EXTENDED, and <AF DETECTION> on the ECG page of the SYSTEM SETUP window is set to On.

4. REFERENCE

Window	Page	Setting Item	Setting Range	Default Setting	Backup		
ALARM	SLEEP	EXIT SLEEP MODE ON CRISIS ALARM	On, Off	On	OK		
		SLEEP MODE WILL END AT	00:00 to 23:59	06:00			
	NETWORK	COMMUNICATION LOSS NOTIFICATION	RE-ALARM, NO SOUND, OFF	OFF			
	ALARM CAP	ADULT, CHILD, NEONATE	HR/PR	Upper		OFF, 16 to 300 beats/min*	ADULT: 160 beats/min CHILD: 190 beats/min NEONATE: 220 beats/min
				Lower		OFF, 15 to 299 beats/min	ADULT: 30 beats/min CHILD: 60 beats/min NEONATE: 80 beats/min
			RR	Upper		OFF, 2 to 150 counts/min	OFF
				Lower		OFF, 0 to 148 counts/min	
			APNEA	Upper		OFF, 5 to 40 s	ADULT, CHILD: 30 s NEONATE: 20 s
			CO ₂ (E)	Upper		OFF, 2 to 99 mmHg OFF, 0.2 to 13.0 kPa	OFF
				Lower		OFF, 1 to 98 mmHg OFF, 0.1 to 12.9 kPa	
			SpO ₂	Upper		OFF, 51 to 100%SpO ₂	ADULT, CHILD: OFF NEONATE: 98%SpO ₂
				Lower		OFF, 50 to 99%SpO ₂	85%SpO ₂
			SpO ₂ -2	Upper		OFF, 51 to 100%SpO ₂	ADULT, CHILD: OFF NEONATE: 98%SpO ₂
				Lower		OFF, 50 to 99%SpO ₂	85%SpO ₂
			ART-SYS	Upper		OFF, -48 to 300 mmHg OFF, -6.0 to 40.0 kPa	OFF
						ADULT: 70 mmHg CHILD: 50 mmHg NEONATE: 40 mmHg	
				Lower		OFF, -50 to 298 mmHg	ADULT: 9.5 kPa CHILD: 6.5 kPa NEONATE: 5.5 kPa
						OFF, -6.5 to 39.5 kPa	

* The ALARM CAP setting only applies when both “EXT TACHY” and “EXT BRADY” are set to OFF.

Window	Page		Setting Item		Setting Range	Default Setting	Backup	
ALARM	ALARM CAP	ADULT, CHILD, NEONATE	ART-DIA	Upper	OFF, -48 to 300 mmHg OFF, -6.0 to 40.0 kPa	OFF	OK	
				Lower	OFF, -50 to 298 mmHg OFF, -6.5 to 39.5 kPa	OFF		
			ART-MEAN	Upper	OFF, -48 to 300 mmHg OFF, -6.0 to 40.0 kPa	OFF		
				Lower	OFF, -50 to 298 mmHg OFF, -6.5 to 39.5 kPa	ADULT: 50 mmHg CHILD: 40 mmHg NEONATE: 25 mmHg ADULT: 6.5 kPa CHILD: 5.5 kPa NEONATE: 3.5 kPa		
			PAP-SYS	Upper	OFF, -48 to 300 mmHg OFF, -6.0 to 40.0 kPa	OFF		
				Lower	OFF, -50 to 298 mmHg OFF, -6.5 to 39.5 kPa	OFF		
			PAP-DIA	Upper	OFF, -48 to 300 mmHg OFF, -6.0 to 40.0 kPa	OFF		
				Lower	OFF, -50 to 298 mmHg OFF, -6.5 to 39.5 kPa	OFF		
			PAP-MEAN	Upper	OFF, -48 to 300 mmHg OFF, -6.0 to 40.0 kPa	OFF		
				Lower	OFF, -50 to 298 mmHg OFF, -6.5 to 39.5 kPa	OFF		
			CVP-MEAN	Upper	OFF, -48 to 300 mmHg OFF, -6.0 to 40.0 kPa	OFF		
				Lower	OFF, -50 to 298 mmHg OFF, -6.5 to 39.5 kPa	OFF		
			LATCHING* ¹	VITAL AND ARRHYTHMIA ALARM LATCHING	CRISIS, WARNING* ² , ADVISORY* ³	AUDIBLE AND VISUAL, NONE		NONE
			COLOR	BASIC PARAM	ECG			
	RESP/CO ₂					white		
	SpO ₂					cyan		
	SpO ₂ -2					yellow		
	NIBP				Green, cyan, salmon, sky blue, yellow, light yellow, white, pink, yellow green, purple, red, orange	pink		
	BIS					orange		
	CO					white		
	PR (SpO ₂), PI (SpO ₂)					sky blue		
PR (SpO ₂ -2), PI (SpO ₂ -2)					light yellow			

*¹ Not available for BSM-6000K series.

*² WARNING is fixed to NONE if CRISIS is set to NONE.

*³ ADVISORY is fixed to NONE if CRISIS or WARNING is set to NONE.

4. REFERENCE

Window	Page	Setting Item	Setting Range	Default Setting	Backup
COLOR	PRESS	P1 to P7, ART, ART2, RAD, DORS, AO, FEM, UA, LVP	Green, cyan, salmon, sky blue, yellow, light yellow, white, pink, yellow green, purple, red, orange	red	OK
		UV, CVP, RAP		sky blue	
		PAP, RVP, LAP		yellow	
		ICP to ICP4		light yellow	
		PPV/SPV		yellow green	
	TEMP	T1, T3, Tskin to Tskin3, Tb	Green, cyan, salmon, sky blue, yellow, light yellow, white, pink, yellow green, purple, red, orange	orange	
		T2, T4, Trect, Tcore, Tnaso, Teso, Tt ymp, Tart, Tven, Tblad, Taxil, Tb, ΔT, ΔT2		light yellow	
	GAS	RESP/CO ₂	Green, cyan, salmon, sky blue, yellow, light yellow, white, pink, yellow green, purple, red, orange	white	
		O ₂		green	
		N ₂ O		sky blue	
		HAL		red	
		ISO		purple	
		ENF		orange	
		SEV		yellow	
		DES		cyan	
		MAC		orange	
	OTHER PARAM	VENT	Green, cyan, salmon, sky blue, yellow, light yellow, white, pink, yellow green, purple, red, orange	white	
		CCO		white	
		Tb		orange	
		SvO ₂		purple	
		AP		orange	
		FLOW/Paw*		white	
		EEG		yellow green	
		SVR		light yellow	
		SVV		yellow green	
		tcPO ₂		sky blue	
		tcPCO ₂		purple	
ALARM		ALARM MODE COLOR		Green, salmon, sky blue, light yellow, white, pink, yellow green, purple	green
RECORD	RECORDER	MANUAL RECORD	REAL TIME, DELAY	DELAY	
		MANUAL RECORD TIME	CONTINUOUS, 10 s, 20 s, 30 s	10 s	
		REVIEW	RECORD PAGE, RECORD ALL	RECORD PAGE	
		PERIODIC FREE INTERVAL	1 to 120 min	15 min	
		FEED PAPER AFTER RECORDING	On, Off	Off	
		RECORD ON CENTRAL MONITOR	—	—	
	PRINTER	PAPER SIZE	A4, LETTER	A4	
		12 LEAD ECG PRINT FORMAT	6 ROWS × 2 COLS, 12 ROWS × 1 COL, 3 ROWS × 4 COLS	12 ROWS × 1 COL	
		IP ADDRESS	0 to 255. 0 to 255. 0 to 255. 0 to 255.	0.0.0.0	
		PRINTER NAME	—	lp	
		HOSPITAL	—	—	

* Not available for BSM-6000A series.

Window	Page	Setting Item	Setting Range		Step	Default Setting	Backup
MASTER	PATIENT TYPE	PATIENT TYPE MASTER SETTING	ADULT, CHILD, NEONATE		—	OR, ICU: ADULT NICU: NEONATE	OK
		NUMBER OF MASTER SETTINGS	1, 3		—	1	
		MASTER SELECT	Adult mode: Child mode: Neonate mode:	Adult Master1 Adult Master2 Adult Master3 Child Master1 Child Master2 Child Master3 Neonate Master1 Neonate Master2 Neonate Master3	—	Adult mode: Adult Master1 Child mode: Child Master1 Neonate mode: Neonate Master1	
	HR/PR	Upper	OFF, 16 to 300 beats/min*1*2	1	ADULT: 140 beats/min CHILD: 170 beats/min NEONATE: 200 beats/min		
		Lower	OFF, 15 to 299 beats/min*1*2		ADULT: 50 beats/min CHILD: 75 beats/min NEONATE: 100 beats/min		
	RR	Upper	OFF, 2 to 150 counts/min*1*2	2	OFF		
		Lower	OFF, 0 to 148 counts/min*1*2				
	APNEA	Upper	OFF, 5 to 40 s*1*2	5	20 s		
	CO ₂	Upper	OFF, 2 to 99 mmHg*1*2	1	OFF		
			OFF, 0.2 to 13.0 kPa*1*2	0.1			
		Lower	OFF, 1 to 98 mmHg*1*2	1	OFF		
			OFF, 0.1 to 12.9 kPa*1*2	0.1			
	SpO ₂	Upper	OFF, 51 to 100%SpO ₂ *1*2	1	ADULT, CHILD: OFF NEONATE: 95%SpO ₂		
		Lower	OFF, 50 to 99%SpO ₂ *1*2		ADULT, CHILD: 90%SpO ₂ NEONATE: 85%SpO ₂		
	SpO ₂₋₂ *3	Upper	OFF, 51 to 100%SpO ₂ *1*2	1	ADULT, CHILD: OFF NEONATE: 95%SpO ₂		
		Lower	OFF, 50 to 99%SpO ₂ *1*2		ADULT, CHILD: 90%SpO ₂ NEONATE: 85%SpO ₂		
	ΔSpO ₂	Upper	OFF, 1 to 50%SpO ₂	1	5%SpO ₂		
	BIS	Upper	OFF, 1 to 100	1	OFF		
		Lower	OFF, 0 to 99		40		

*1 On BSM-6000A series, if <CRISIS VITAL ALARM MANAGEMENT> on the SYSTEM CONFIGURATION screen is turned on and the “ALARM PRIORITY” on the SYSTEM SETUP window is set to CRISIS, the alarm master cannot be set to OFF.

*2 On BSM-6000A series, if <ALARM CAP> on the SYSTEM CONFIGURATION screen is turned on, the alarm master is affected by the “ALARM CAP” setting on the SYSTEM SETUP window.

*3 Available only when an AY-660P, AY-661P, AY-663P, AY-671P or AY-673P input unit or BSM-1700 series bedside monitor is used.

4. REFERENCE

Window	Page	Setting Item	Setting Range		Step	Default Setting	Backup	
MASTER	MAIN ALARMS	NIBP-SYS	Upper	OFF, 15 to 260 mmHg	5	ADULT: 180 mmHg CHILD: 140 mmHg NEONATE: 100 mmHg	OK	
				OFF, 1.5 to 35.0 kPa	0.5	ADULT: 24.0 kPa CHILD: 18.5 kPa NEONATE: 13.5 kPa		
			Lower	OFF, 10 to 255 mmHg	5	ADULT: 80 mmHg CHILD: 65 mmHg NEONATE: 50 mmHg		
				OFF, 1.0 to 34.5 kPa	0.5	ADULT: 10.5 kPa CHILD: 8.5 kPa NEONATE: 6.5 kPa		
		NIBP-DIA	Upper	OFF, 15 to 260 mmHg	5	OFF		
				OFF, 1.5 to 35.0 kPa	0.5			
			Lower	OFF, 10 to 255 mmHg	5	OFF		
				OFF, 1.0 to 34.5 kPa	0.5			
		NIBP-MAP	Upper	OFF, 15 to 260 mmHg	5	OFF		
				OFF, 1.5 to 35.0 kPa	0.5			
			Lower	OFF, 10 to 255 mmHg	5	OFF		
				OFF, 1.0 to 34.5 kPa	0.5			
	ECG ALARMS	HR/PR	Upper	OFF, 16 to 300 beats/min*1*2	1	ADULT: 140 beats/min CHILD: 170 beats/min NEONATE: 200 beats/min		
				Lower		OFF, 15 to 299 beats/min*1*2		ADULT: 50 beats/min CHILD: 75 beats/min NEONATE: 100 beats/min
		VPC	Upper	OFF, 1 to 99 beats/min	1	OFF		
		ST-I to ST-V6	Upper	OFF, -1.99 to 2.00 mV	0.01	OFF		
				OFF, -19.9 to 20.0 mm	0.1			
			Lower	OFF, -2.00 to 1.99 mV	0.01	OFF		
				OFF, -20.0 to 19.9 mm	0.1			
		PRESS1 ALARMS	P1-SYS to P7-SYS	Upper	OFF, -48 to 300 mmHg	2		OFF
					OFF, -6.0 to 40.0 kPa	0.5		
				Lower	OFF, -50 to 298 mmHg	2		
	OFF, -6.5 to 39.5 kPa				0.5			
	P1-DIA to P7-DIA		Upper	OFF, -48 to 300 mmHg	2	OFF		
OFF, -6.0 to 40.0 kPa				0.5				
Lower			OFF, -50 to 298 mmHg	2				
			OFF, -6.5 to 39.5 kPa	0.5				

*1 On BSM-6000A series, if <CRISIS VITAL ALARM MANAGEMENT> on the SYSTEM CONFIGURATION screen is turned on and the “ALARM PRIORITY” on the SYSTEM SETUP window is set to CRISIS, the alarm master cannot be set to OFF.

*2 On BSM-6000A series, if <ALARM CAP> on the SYSTEM CONFIGURATION screen is turned on, the alarm master is affected by the “ALARM CAP” setting on the SYSTEM SETUP window.

Window	Page	Setting Item		Setting Range	Step	Default Setting	Backup
MASTER	PRESS2 ALARMS	P1-MEAN to P7-MEAN	Upper	OFF, -48 to 300 mmHg	2	OFF	OK
				OFF, -6.0 to 40.0 kPa	0.5		
			Lower	OFF, -50 to 298 mmHg	2		
				OFF, -6.5 to 39.5 kPa	0.5		
		ART-SYS, ART2-SYS	Upper	OFF, -48 to 300 mmHg*	2	OFF	
				OFF, -6.0 to 40.0 kPa*	0.5		
			Lower	OFF, -50 to 298 mmHg*	2	ADULT: 80 mmHg CHILD: 66 mmHg NEONATE: 50 mmHg	
				OFF, -6.5 to 39.5 kPa*	0.5	ADULT: 10.5 kPa CHILD: 9.0 kPa NEONATE: 6.5 kPa	
		ART-DIA, ART2-DIA	Upper	OFF, -48 to 300 mmHg*	2	OFF	
				OFF, -6.0 to 40.0 kPa*	0.5		
			Lower	OFF, -50 to 298 mmHg*	2	OFF	
				OFF, -6.5 to 39.5 kPa*	0.5		
		ART-MEAN, ART2-MEAN	Upper	OFF, -48 to 300 mmHg*	2	OFF	
				OFF, -6.0 to 40.0 kPa*	0.5		
			Lower	OFF, -50 to 298 mmHg*	2	ADULT: 60 mmHg CHILD: 46 mmHg NEONATE: 30 mmHg	
				OFF, -6.5 to 39.5 kPa*	0.5	ADULT: 8.0 kPa CHILD: 6.0 kPa NEONATE: 4.0 kPa	
		RAD-SYS, AO-SYS, FEM-SYS	Upper	OFF, -48 to 300 mmHg	2	OFF	
				OFF, -6.0 to 40.0 kPa	0.5		
			Lower	OFF, -50 to 298 mmHg	2	ADULT: 80 mmHg CHILD: 66 mmHg NEONATE: 50 mmHg	
				OFF, -6.5 to 39.5 kPa	0.5	ADULT: 10.5 kPa CHILD: 9.0 kPa NEONATE: 6.5 kPa	
		RAD-DIA, AO-DIA, FEM-DIA	Upper	OFF, -48 to 300 mmHg	2	OFF	
				OFF, -6.0 to 40.0 kPa	0.5		
			Lower	OFF, -50 to 298 mmHg	2	OFF	
				OFF, -6.5 to 39.5 kPa	0.5		
RAD-MEAN, AO-MEAN, FEM-MEAN	Upper	OFF, -48 to 300 mmHg	2	OFF			
		OFF, -6.0 to 40.0 kPa	0.5				
	Lower	OFF, -50 to 298 mmHg	2	ADULT: 60 mmHg CHILD: 46 mmHg NEONATE: 30 mmHg			
		OFF, -6.5 to 39.5 kPa	0.5	ADULT: 8.0 kPa CHILD: 6.0 kPa NEONATE: 4.0 kPa			

* On BSM-6000A series, if <ALARM CAP> on the SYSTEM CONFIGURATION screen is turned on, the alarm master of ART-SYS, ART-DIA and ART-MEAN is affected by the “ALARM CAP” setting on the SYSTEM SETUP window.

4. REFERENCE

Window	Page	Setting Item	Setting Range	Step	Default Setting	Backup	
MASTER	PRESS2 ALARMS	DORS-SYS	Upper	OFF, -48 to 300 mmHg	2	ADULT: OFF CHILD: 200 mmHg NEONATE: OFF	OK
				OFF, -6.0 to 40.0 kPa	0.5	ADULT: OFF CHILD: 26.5 kPa NEONATE: OFF	
			Lower	OFF, -50 to 298 mmHg	2	ADULT: 80 mmHg CHILD: 66 mmHg NEONATE: 50 mmHg	
				OFF, -6.5 to 39.5 kPa	0.5	ADULT: 10.5 kPa CHILD: 9.0 kPa NEONATE: 6.5 kPa	
		DORS-DIA	Upper	OFF, -48 to 300 mmHg	2	OFF	
				OFF, -6.0 to 40.0 kPa	0.5	OFF	
			Lower	OFF, -50 to 298 mmHg	2	OFF	
				OFF, -6.5 to 39.5 kPa	0.5	OFF	
		DORS-MEAN	Upper	OFF, -48 to 300 mmHg	2	ADULT: OFF CHILD: 186 mmHg NEONATE: OFF	
				OFF, -6.0 to 40.0 kPa	0.5	ADULT: OFF CHILD: 25.0 kPa NEONATE: OFF	
			Lower	OFF, -50 to 298 mmHg	2	ADULT: 60 mmHg CHILD: 46 mmHg NEONATE: 30 mmHg	
				OFF, -6.5 to 39.5 kPa	0.5	ADULT: 8.0 kPa CHILD: 6.0 kPa NEONATE: 4.0 kPa	
		UA-SYS	Upper	OFF, -48 to 300 mmHg	2	OFF	
				OFF, -6.0 to 40.0 kPa	0.5	OFF	
			Lower	OFF, -50 to 298 mmHg	2	OFF	
				OFF, -6.5 to 39.5 kPa	0.5	OFF	
		UA-DIA	Upper	OFF, -48 to 300 mmHg	2	OFF	
				OFF, -6.0 to 40.0 kPa	0.5	OFF	
			Lower	OFF, -50 to 298 mmHg	2	OFF	
				OFF, -6.5 to 39.5 kPa	0.5	OFF	
		UA-MEAN, UV-MEAN	Upper	OFF, -48 to 300 mmHg	2	OFF	
				OFF, -6.0 to 40.0 kPa	0.5	OFF	
			Lower	OFF, -50 to 298 mmHg	2	OFF	
				OFF, -6.5 to 39.5 kPa	0.5	OFF	

Window	Page	Setting Item		Setting Range	Step	Default Setting	Backup
MASTER	PRESS3 ALARMS	PAP-SYS	Upper	OFF, -48 to 300 mmHg*	2	OFF	OK
				OFF, -6.0 to 40.0 kPa*	0.5		
			Lower	OFF, -50 to 298 mmHg*	2		
				OFF, -6.5 to 39.5 kPa*	0.5		
		PAP-DIA	Upper	OFF, -48 to 300 mmHg*	2		
				OFF, -6.0 to 40.0 kPa*	0.5		
			Lower	OFF, -50 to 298 mmHg*	2		
				OFF, -6.5 to 39.5 kPa*	0.5		
		PAP-MEAN, CVP-MEAN	Upper	OFF, -48 to 300 mmHg*	2		
				OFF, -6.0 to 40.0 kPa*	0.5		
			Lower	OFF, -50 to 298 mmHg*	2		
				OFF, -6.5 to 39.5 kPa*	0.5		
		RVP-SYS, LVP-SYS	Upper	OFF, -48 to 300 mmHg	2		
				OFF, -6.0 to 40.0 kPa	0.5		
			Lower	OFF, -50 to 298 mmHg	2		
				OFF, -6.5 to 39.5 kPa	0.5		
		RVP-DIA, LVP-DIA	Upper	OFF, -48 to 300 mmHg	2		
				OFF, -6.0 to 40.0 kPa	0.5		
			Lower	OFF, -50 to 298 mmHg	2		
				OFF, -6.5 to 39.5 kPa	0.5		
		RAP-MEAN, RVP-MEAN, LAP-MEAN, LVP-MEAN, ICP-MEAN, ICP2-MEAN to ICP4-MEAN	Upper	OFF, -48 to 300 mmHg	2		
				OFF, -6.0 to 40.0 kPa	0.5		
			Lower	OFF, -50 to 298 mmHg	2		
				OFF, -6.5 to 39.5 kPa	0.5		
	TEMP ALARMS	T1 to T4, Tskin, Tskin2, Tskin3, Trect, Tcore, Tnaso, Teso, Ttymp	Upper	OFF, 0.1 to 45.0°C	0.1	ADULT: 38.0°C CHILD: 38.5°C NEONATE: 39.0°C	
				OFF, 33.0 to 113.0°F	1.0	ADULT: 100°F CHILD: 101°F NEONATE: 102°F	
				Lower	OFF, 0.0 to 44.9°C	0.1	OFF
					OFF, 32.0 to 112.0°F	1.0	
			Tblad, Taxil	Upper	OFF, 0.1 to 45.0°C	0.1	ADULT: 38.0°C CHILD: 38.5°C NEONATE: 39.0°C
					OFF, 33.0 to 113.0°F	1.0	ADULT: 100°F CHILD: 101°F NEONATE: 102°F
Lower				OFF, 0.0 to 44.9°C	0.1	OFF	
				OFF, 32.0 to 112.0°F	1.0		
Tb		Upper	OFF, 15.1 to 45.0°C	0.1	ADULT: 38.0°C CHILD: 38.5°C NEONATE: 39.0°C		
			OFF, 51.0 to 113.0°F	1.0	ADULT: 100°F CHILD: 101°F NEONATE: 102°F		
		Lower	OFF, 15.0 to 44.9°C	0.1	OFF		
			OFF, 50.0 to 112.0°F	1.0			
ΔT, ΔT2		Upper	OFF, 0.1 to 45.0°C	0.1	OFF		
			OFF, 1.0 to 113.0°F	1.0			

* On BSM-6000A series, if <ALARM CAP> on the SYSTEM CONFIGURATION screen is turned on, the alarm master is affected by the “ALARM CAP” setting on the SYSTEM SETUP window.

4. REFERENCE

Window	Page	Setting Item	Setting Range		Step	Default Setting	Backup
MASTER	GAS ALARMS	RR	Upper	OFF, 2 to 150 counts/min ^{*1*2}	2	OFF	OK
			Lower	OFF, 0 to 148 counts/min ^{*1*2}		OFF	
		APNEA	Upper	OFF, 5 to 40 s	5	20 s	
			Lower	—	—	—	
		CO ₂ (E)	Upper	OFF, 2 to 99 mmHg ^{*1*2}	1	OFF	
				OFF, 0.2 to 13.0 kPa ^{*1*2}	0.1		
			Lower	OFF, 1 to 98 mmHg ^{*1*2}	1	OFF	
				OFF, 0.1 to 12.9 kPa ^{*1*2}	0.1		
		CO ₂ (I)	Upper	OFF, 1 to 99 mmHg	1	ADULT OR, CHILD: 3 mmHg ADULT ICU/ NICU, NEONATE: OFF	
				OFF, 0.1 to 13.0 kPa	0.1	ADULT OR, CHILD: 0.4 kPa ADULT ICU/ NICU, NEONATE: OFF	
		O ₂ (E)	Upper	OFF, 11 to 100%	1	OFF	
			Lower	OFF, 10 to 99%		OFF	
		O ₂ (I)	Upper	OFF, 19 to 100%	1	OFF	
			Lower	18 to 99%		18%	
		N ₂ O(E)	Upper	OFF, 1 to 100%	1	OFF	
			Lower	OFF, 0 to 99%		OFF	
		N ₂ O(I)	Upper	OFF, 1 to 100%	1	80%	
			Lower	OFF, 0 to 99%		OFF	
		HAL(E)	Upper	OFF, 0.1 to 7.0%	0.1	OFF	
			Lower	OFF, 0.0 to 6.9%		OFF	
		HAL(I)	Upper	OFF, 0.1 to 7.0%	0.1	4.0%	
			Lower	OFF, 0.0 to 6.9%		OFF	
		ISO(E)	Upper	OFF, 0.1 to 7.0%	0.1	OFF	
			Lower	OFF, 0.0 to 6.9%		OFF	
		ISO(I)	Upper	OFF, 0.1 to 7.0%	0.1	5.0%	
			Lower	OFF, 0.0 to 6.9%		OFF	
		ENF(E)	Upper	OFF, 0.1 to 7.0%	0.1	OFF	
			Lower	OFF, 0.0 to 6.9%		OFF	
		ENF(I)	Upper	OFF, 0.1 to 7.0%	0.1	5.0%	
			Lower	OFF, 0.0 to 6.9%		OFF	
		SEV(E)	Upper	OFF, 0.1 to 7.0%	0.1	OFF	
			Lower	OFF, 0.0 to 6.9%		OFF	
SEV(I)	Upper	OFF, 0.1 to 7.0%	0.1	6.0%			
	Lower	OFF, 0.0 to 6.9%		OFF			
DES(E)	Upper	OFF, 0.1 to 20.0%	0.1	OFF			
	Lower	OFF, 0.0 to 19.9%		OFF			
DES(I)	Upper	OFF, 0.1 to 20.0%	0.1	12.0%			
	Lower	OFF, 0.0 to 19.9%		OFF			

*1 On BSM-6000A series, if <CRISIS VITAL ALARM MANAGEMENT> on the SYSTEM CONFIGURATION screen is turned on and the “ALARM PRIORITY” on the SYSTEM SETUP window is set to CRISIS, the alarm master cannot be set to OFF.

*2 On BSM-6000A series, if <ALARM CAP> on the SYSTEM CONFIGURATION screen is turned on, the alarm master is affected by the “ALARM CAP” setting on the SYSTEM SETUP window.

Window	Page	Setting Item	Setting Range		Step	Default Setting	Backup
MASTER	OTHER ALARMS	MV*1	Upper	OFF, 0.1 to 30.0 L/min	0.1	ADULT: 10.0 CHILD: 6.0 NEONATE: OFF	OK
			Lower	OFF, 0.0 to 29.9 L/min		ADULT, CHILD: 2.0 NEONATE: OFF	
		Ppeak*1	Upper	OFF, 1 to 100 cmH ₂ O	1	ADULT, CHILD: 40 NEONATE: OFF	
			Lower	OFF, 0 to 99 cmH ₂ O		ADULT, NEONATE: OFF CHILD: 8	
		PEEP*1	Upper	OFF, 1 to 50 cmH ₂ O	1	ADULT, CHILD: 10 NEONATE: OFF	
			Lower	OFF, 0 to 49 cmH ₂ O		ADULT, NEONATE: OFF CHILD: 2	
		SEF	Upper	OFF, 1.0 to 60.0 Hz	0.5	OFF	
			Lower	OFF, 0.5 to 59.5 Hz		OFF	
		TP	Upper	OFF, 0.02 to 9.99 nW	0.01	OFF	
			Lower	OFF, 0.01 to 9.98 nW		OFF	
		CCO*1	Upper	OFF, 1.0 to 20.0 L/min	0.1	OFF	
			Lower	OFF, 1.0 to 19.9 L/min		OFF	
	CCI*1	Upper	OFF, 0.1 to 20.0 L/min/m ²	0.1	OFF		
		Lower	OFF, 1.0 to 19.9 L/min/m ²		OFF		
	ARRHYTH	ARRHYTHMIA ANALYSIS	ON, OFF	—	ON		
		ASYSTOLE	ON fixed 3 to 10 s	1	ADULT, CHILD: 5 s NEONATE: 3 s		
		VF	ON fixed	—	ON		
		VT*2	V BRADY alarm limit to 300 bpm	1	ADULT CHILD: 100 bpm NEONATE: 140 bpm		
			VPC RUN alarm limit to 9 beats	1	6 beats		
		EXT TACHY*2	ON, OFF	—	BSM-6000A: ON BSM-6000K: OFF		
			upper heart rate alarm limit to 300	1	ADULT: 160 bpm CHILD: 190 bpm NEONATE: 220 bpm		
		EXT BRADY*2	ON, OFF	—	BSM-6000A: ON BSM-6000K: OFF		
			15 to lower heart rate alarm limit	1	ADULT: 40 bpm CHILD: 60 bpm NEONATE: 80 bpm		
		V BRADY*2	ON, OFF	—	ADULT OR: OFF ICU/NICU: ON CHILD, NEONATE: OFF		
15 to 299 bpm			1	ADULT, CHILD: 50 bpm NEONATE: 60 bpm			

*1 Not available for BSM-6000A series.

*2 Available only when <ARRHYTHMIA TYPE> on the ECG page of the SYSTEM SETUP window is set to EXTENDED.

4. REFERENCE

Window	Page	Setting Item	Setting Range	Step	Default Setting	Backup
MASTER	ARRHYTH	VPC RUN	ON, OFF	—	ADULT OR: OFF ICU/NICU: ON CHILD, NEONATE: OFF	OK
			16 to 300 bpm* ¹	1	ADULT, CHILD: 100 bpm NEONATE: 140 bpm	
			3 to 8 beats	1	3 beats	
		SV TACHY* ¹	ON, OFF	—	OFF	
			16 to 300 bpm	1	ADULT, CHILD: 170 bpm NEONATE: 210 bpm	
			3 to 9 beats	1	6 beats	
		PAUSE* ¹	ON, OFF	—	ON	
			1.0 to 3.0 s	0.1	ADULT, CHILD: 3.0 s NEONATE: 1.5 s	
		V RHYTHM* ¹	ON, OFF	—	ADULT OR: OFF ICU/NICU: ON CHILD, NEONATE: OFF	
		COUPLET	ON, OFF	—	OFF	
		EARLY VPC	ON, OFF	—	OFF	
		MULTIFORM* ¹	ON, OFF	—	OFF	
		BIGEMINY	ON, OFF	—	OFF	
		TRIGEMINY* ¹	ON, OFF	—	OFF	
		AF* ²	ON, OFF	—	ADULT: ON CHILD, NEONATE: OFF	
		IRREGULAR RR* ¹	ON, OFF	—	OFF	
		PROLONGED RR* ¹	ON, OFF	—	OFF	
		NO PACER PULSE* ¹	ON, OFF	—	OFF	
		PACER NON-CAPTURE* ¹	ON, OFF	—	OFF	
			40 to 480 ms	4	400 ms	

*¹ Available only when <ARRHYTHMIA TYPE> on the ECG page of the SYSTEM SETUP window is set to EXTENDED.

*² Not available for BSM-6000K series. Available only when <ARRHYTHMIA TYPE> on the ECG page of the SYSTEM SETUP window is set to EXTENDED, and <AF DETECTION> on the ECG page of the SYSTEM SETUP window is set to On.

Window	Page	Setting Item	Setting Range	Default Setting	Backup
RY-910P/MOUSE		REMOTE CONTROL CHANNEL	CH 1, CH 2, CH 3, CH 4, CH 5, CH 6, CH 7, CH 8, CH 9, ALL	ALL	
		REMOTE CONTROL CURSOR ACCELERATION	SLOW to FAST	medium	
		MOUSE CURSOR ACCELERATION			
KEYS		FUNCTION KEYS	FREEZE, TOUCHKEYS OFF, ZERO ALL, SUSPEND ALARMS, ALL ALARMS OFF* ¹ , SUSPEND MONITORING* ² , SLEEP* ³ , BYPASS* ⁴ , NIBP START/STOP, SYNC SOUND ON/OFF, MENU, HOME, LARGE NUMERICS, DISCHARGE (BSM-6000K series only), NEXT CASE (BSM-6000A series only)* ⁵ , TRANSPORT DATA (BSM-6000K series only)* ⁶ , X-PORT DATA (BSM-6000A series only)* ⁶ , VENOUS PUNCTURE, 12 LEAD ANALYSIS* ⁷ , CO, PCWP, GAS, INTERBED, DRUG, LUNG FUNCTION, TIMER, TREND GRAPH, TREND DATA, RECALL, ALARM HISTORY, FULL DISC, ST TREND* ⁸ , NIBP TREND, HEMO TREND, LUNG TREND, OCRG* ⁹ , 12 LEAD* ⁷ , aEEG, PRINT WAVE, PRINT OCRG, RECORD OCRG, RECORD WAVE, NONE	1: MENU 2: TREND GRAPH 3: ZERO ALL 4: ALARM HISTORY	OK
		REMOTE CONTROL KEYS		NONE	

*¹ Available when site is ICU or NICU and alarm off type is set to ALL ALARMS OFF, or when site is OR and alarm inactivation and alarm off type are set to ALL ALARMS OFF.

*² Available only when alarm inactivation is set to SUSPEND ALARMS.

*³ Available only when site is ICU or NICU and alarm inactivation is set to SUSPEND ALARMS.

*⁴ Available only when site is OR and alarm off type is "BYPASS".

*⁵ Available only when site is OR.

*⁶ Available only when data transport setting is "ENABLE".

*⁷ On BSM-6000A series, not available when site is NICU.

*⁸ Not available when <NEONATE ST MEASUREMENT> is turned off and the patient type is neonate.

*⁹ Available only when site is NICU.

General Requirements for Connecting Medical Electrical Systems

When more than one electrical instrument is used, there may be electrical potential difference between the instruments. Potential difference between instruments may cause current to flow to the patient connected to the instruments, resulting in electrical shock. Therefore, electrical instruments must be appropriately installed as specified in IEC 60601-1-1: 2000 Second edition.

The following is an extract from IEC 60601-1-1 “Medical electrical equipment Part 1-1: General requirements for safety”. For details, refer to IEC 60601-1-1 and consult with a biomedical engineer.

Examples of combinations of MEDICAL ELECTRICAL EQUIPMENT and non-medical electrical equipment

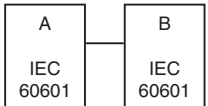
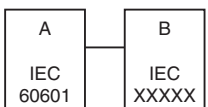
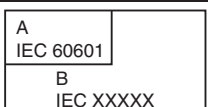
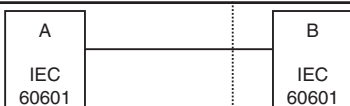
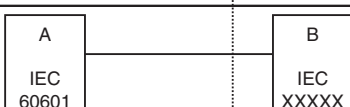
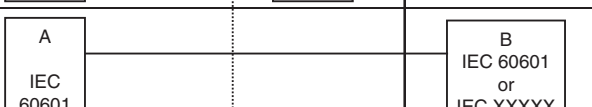
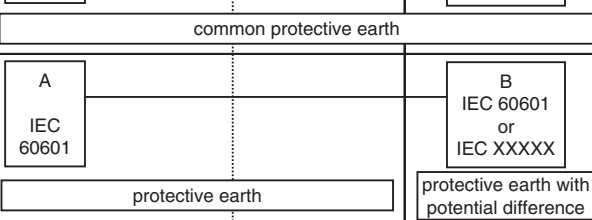
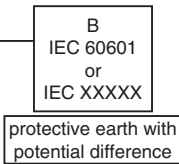
Situation No.	Medically used room		Non-medically used room	Feasible solution (See clause 19 in all situations)
	Inside the PATIENT ENVIRONMENT	Outside the PATIENT ENVIRONMENT		
1	1a Items A and B in PATIENT ENVIRONMENT			
	1b Items A and B in PATIENT ENVIRONMENT			For B: Additional protective earth or separating transformer
	1c Item A powered from specified power supply in item B in PATIENT ENVIRONMENT			For B: Additional protective earth or separating transformer
2	2a Item A in PATIENT ENVIRONMENT and item B in medically used room			
	2b Item A in PATIENT ENVIRONMENT and item B in medically used room			For B: See 19.201 and its rationale
3	3a Item A in PATIENT ENVIRONMENT and item B in non-medically used room			For B: See 19.201 and its rationale
	3b Item A in PATIENT ENVIRONMENT and item B in non-medically used room			For B: Additional protective earth or SEPARATION DEVICE

KEY TO TABLE

- Additional protective earth: If necessary, provide additional protective earthing, which is permanently connected (see also 58.201).
NOTE: Equipment modification may be required.
- Separating transformer: If necessary, limit the ENCLOSURE LEAKAGE CURRENT, by using an additional separating transformer according to annex EEE.
NOTE 1: No equipment modification is required.
NOTE 2: A separating transformer is a transformer with one or more input winding(s) separated from the output winding(s) by at least basic insulation [IEC 60989].
- SEPARATION DEVICE: If necessary, apply SEPARATION DEVICE.
- IEC 60601: MEDICAL ELECTRICAL EQUIPMENT in compliance with IEC 60601.
- IEC XXXXX: Non-medical equipment in compliance with relevant IEC safety standards.

Connector Pin Assignment

MU-631R/MU-651R/MU-671R Main Unit

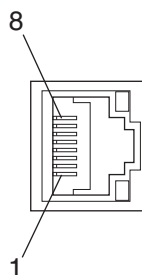

Network Socket

Connection cable: Network cable

Pin assignment:

Pin No.	Signal	Pin No.	Signal
1	TD+	5	NC
2	TD-	6	RD-
3	RD+	7	NC
4	NC	8	NC

ZS Socket

Connection cable: Transmitter cable

Pin assignment:

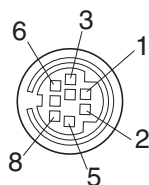

Pin No.	Signal	Pin No.	Signal
1	ZS RESP	5	ZS_XRST
2	FGND	6	ZS_XINIT
3	ZS_XCNFM	7	ZS_XRXD
4	+5 V	8	ZS_XTXD

QI-631P Interface

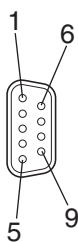

RS-232C Socket

Connection cable: Serial cable

Pin assignment:

Pin No.	Signal	Pin No.	Signal
1	Not used	6	DSR
2	RxD	7	RTS
3	TxD	8	CTS
4	DTR	9	Not used
5	GND		

RGB Socket

Connection cable: RGB cable

Pin assignment:

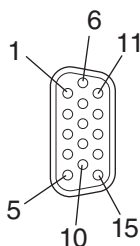

Pin No.	Signal	Pin No.	Signal
1	L_RED	9	5V
2	L_GREEN	10	GND
3	L_BLUE	11	Not used
4	Not used	12	Not used
5	GND	13	HSYNC
6	GND	14	VSYNC
7	GND	15	Not used
8	GND		

4. REFERENCE

QI-632P Interface

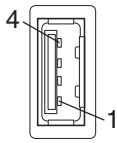

USB Socket

Connection cable: Mouse cable or bar code reader cable

Pin assignment:

Pin No.	Signal
1	5 V
2	D-
3	D+
4	GND

Multi-link Socket

Connection cable: Multi-link cable

Pin assignment:

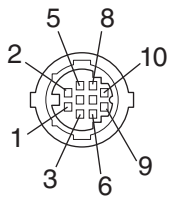

Pin No.	Signal	Pin No.	Signal
1	Tx	6	DET
2	Rx	7	Not used
3	CTS	8	+5 V
4	SYN	9	+12 V
5	xRESET	10	GND

Alarm Socket

Connection cable: YJ-672P nurse call cable

Pin assignment:

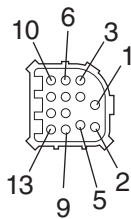

Pin No.	Signal	Pin No.	Signal
1	D GND	8	NCALL_01
2	+12 V	9	NCALL_02
3	EXT_ALARM_R	10	NCALL_03
4	EXT_ALARM_G	11	D GND
5	EXT_ALARM_Y	12	—
6	EXT_ALARM_B	13	—
7	NCALL_00		

QI-634P Interface

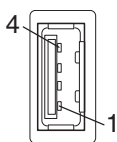

USB Socket

Connection cable: Mouse cable or bar code reader cable

Pin assignment:

Pin No.	Signal
1	5 V
2	D-
3	D+
4	GND

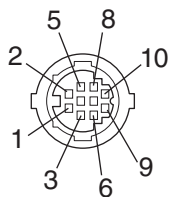

Multi-link Socket

Connection cable: Multi-link cable

Pin assignment:

Pin No.	Signal	Pin No.	Signal
1	Tx	6	DET
2	Rx	7	Not used
3	CTS	8	+5 V
4	SYN	9	+12 V
5	xRESET	10	GND

4

QI-671P Interface

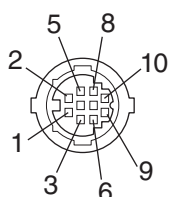

Multi-link Socket

Connection cable: Multi-link cable

Pin assignment:

Pin No.	Signal	Pin No.	Signal
1	Tx	6	DET
2	Rx	7	Not used
3	CTS	8	+5 V
4	SYN	9	+12 V
5	xRESET	10	GND

RS-232C Socket

Connection cable: Serial cable

Pin assignment:

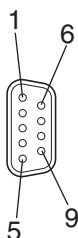

Pin No.	Signal	Pin No.	Signal
1	Not used	6	DSR
2	RxD	7	RTS
3	TxD	8	CTS
4	DTR	9	Not used
5	GND		

Alarm Socket

Connection cable: YJ-672P nurse call cable

Pin assignment:

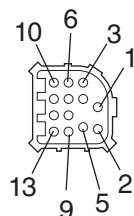

Pin No.	Signal	Pin No.	Signal
1	D GND	8	NCALL_01
2	+12 V	9	NCALL_02
3	EXT_ALARM_R	10	NCALL_03
4	EXT_ALARM_G	11	D GND
5	EXT_ALARM_Y	12	—
6	EXT_ALARM_B	13	—
7	NCALL_00		

4. REFERENCE

RGB Socket

Connection cable: RGB cable

Pin assignment:

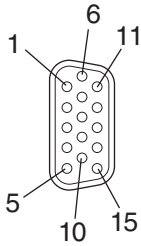

Pin No.	Signal	Pin No.	Signal
1	L_RED	9	5V
2	L_GREEN	10	GND
3	L_BLUE	11	Not used
4	Not used	12	Not used
5	GND	13	HSYNC
6	GND	14	VSYNC
7	GND	15	Not used
8	GND		

QI-672P Interface

Multi-link Socket

Connection cable: Multi-link cable

Pin assignment:

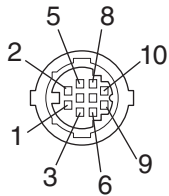

Pin No.	Signal	Pin No.	Signal
1	Tx	6	DET
2	Rx	7	Not used
3	CTS	8	+5 V
4	SYN	9	+12 V
5	xRESET	10	GND

USB Socket

Connection cable: Mouse cable or bar code reader cable

Pin assignment:

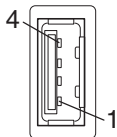

Pin No.	Signal
1	5 V
2	D-
3	D+
4	GND

AY-631P/AY-633P/AY-651P/AY-653P/AY-661P/AY-663P/AY-671P/AY-673P Input Unit and BSM-1700 series Bedside Monitor

ECG/BP OUT Socket

Connection cable: YJ-910P or YJ-920P ECG/BP output cable

Pin assignment:

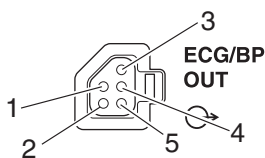

Pin No.	Signal
1	GND
2	SHIELD
3	BP OUT
4	HT OUT
5	ECG OUT



NIHON KOHDEN CORPORATION
 1-31-4 Nishiiochiai, Shinjuku-ku Tokyo 161-8560, Japan
 Phone +81 3-5996-8036
 Fax +81 3-5996-8100

NIHON KOHDEN ITALIA S.r.l.
 Via Fratelli Bronzetti 28, 24124 Bergamo, Italy
 Phone +39 035-219543
 Fax +39 035-232546

North and South America

NIHON KOHDEN AMERICA, INC.
 15353 Barranca Parkway, Irvine, CA 92618, U.S.A.
 Toll-free +1-800-325-0283
 Phone +1 949-580-1555
 Fax +1 949-580-1550

NIHON KOHDEN MEXICO S.A. DE C.V.
 Insurgentes Sur 730, Piso 9 Oriente, Col. Del Valle
 C.P. 03100, Delegacion Benito Juarez, Mexico, D.F.
 Phone +52 55-8851-5550
 Fax +52 55-8851-5580

NIHON KOHDEN DO BRASIL LTDA.
 Rua Diadema, 89, 1º andar, conjuntos 11 a 17, bairro Mauá
 no Município de São Caetano do Sul, Estado de São Paulo
 CEP 09580-670, Brasil
 Phone +55 11-3044-1700
 Fax +55 11-3044-0463

Europe

 European Representative

NIHON KOHDEN EUROPE GmbH
 Raiffeisenstrasse 10, D-61191 Rosbach, Germany
 Phone +49 6003-827-0
 Fax +49 6003-827-599

NIHON KOHDEN DEUTSCHLAND GmbH
 Raiffeisenstrasse 10, D-61191 Rosbach, Germany
 Phone +49 6003-827-0
 Fax +49 6003-827-599

NIHON KOHDEN FRANCE SARL
 8, rue Francois Delage, 94 230 Cachan, France
 Phone +33 1-49-08-05-50
 Fax +33 1-49-08-93-32

NIHON KOHDEN IBERICA S.L.
 C/Ulises 75A, E-28043 Madrid, Spain
 Phone +34 917-161-080
 Fax +34 913-004-676

NIHON KOHDEN UK LTD.
 Trident Court 118, 1 Oakcroft Road
 Chessington, Surrey KT9 1BD, UK
 Phone +44 20-8391-6800
 Fax +44 20-8391-6809

Asia

**SHANGHAI KOHDEN
 MEDICAL ELECTRONIC INSTRUMENT CORP.**
 567 Huancheng Bei Road
 Shanghai Comprehensive Industrial Development Zone
 Shanghai 201401, China
 Phone +86 21-5743-6998
 Fax +86 21-5743-6939

NIHON KOHDEN SINGAPORE PTE LTD
 1 Maritime Square, #10-34 HarbourFront Centre
 Singapore 099253
 Phone +65 6376-2210
 Fax +65 6376-2264

NIHON KOHDEN INDIA PVT. LTD.
 308, Tower A, Spazedge, Sector 47, Sohna Road
 Gurgaon-122 002 Haryana, India
 Toll-free +91 1800-103-8182
 Phone +91 124-493-1000
 Fax +91 124-493-1029

NIHON KOHDEN MIDDLE EAST FZE
 JAFZA One Tower A, 19th floor, Office No. 1912
 Jebel Ali Free Zone, P.O. Box 261516, Dubai, U.A.E.
 Phone +971 4-884-0080
 Fax +971 4-880-0122

NIHON KOHDEN KOREA, INC.
 5F Miso Bldg.
 890-47 Daechi-dong, Gangnam-gu, Seoul, 135-280 Korea
 Phone +82 2-3273-2310
 Fax +82 2-3273-2352

Contact information is accurate as of July 2016. Visit www.nihonkohden.com for the latest information.

The model and serial number of your instrument are identified on the rear or bottom of the unit.
 Write the model and serial number in the spaces provided below. Whenever you call your representative concerning
 this instrument, mention these two pieces of information for quick and accurate service.

Model _____

Serial Number _____

Your Representative
